

BILL OF MATERIALS						
ITEM NO.	MRP#	DRAWING NUMBER	DESCRIPTION	M-00-1002-1/QTY.	M-00-1002-2/QTY.	M-00-1002-3/QTY.
1		MBA-00-10003	WASHER	1	2	3

REV.	DESCRIPTION	DATE	DWN	ENG CKD	MFG CKD	QC CKD	APPV
A	DRAWING RELEASED, -701,-702,-703 CONFIGURATIONS REMOVED	16-DEC-2019	J.P.	-	-	-	E.M.

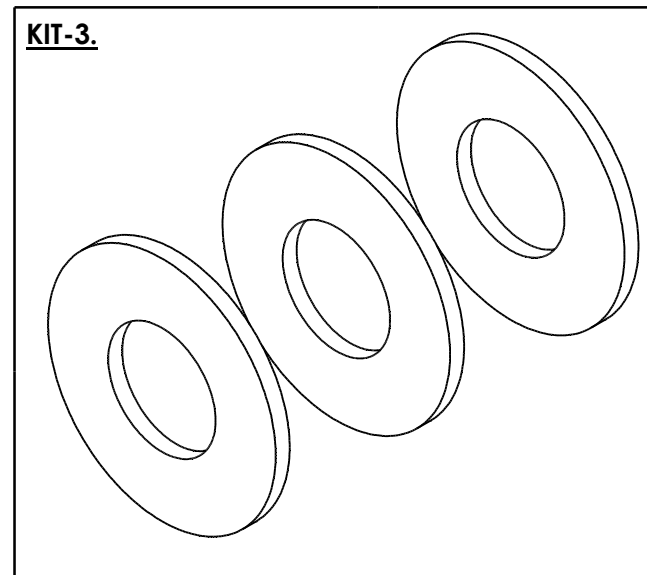
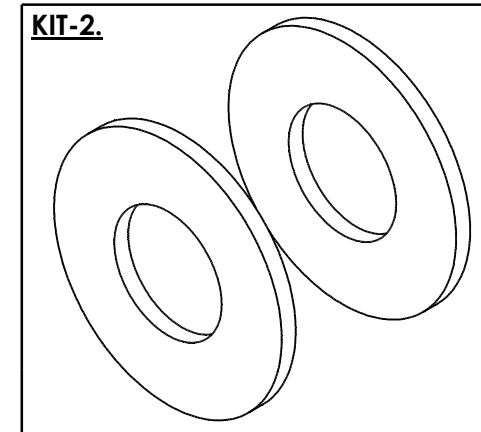
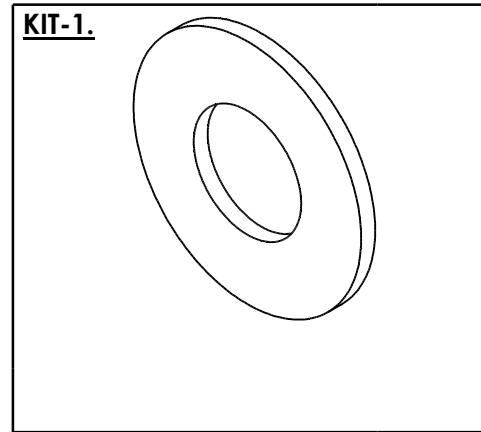
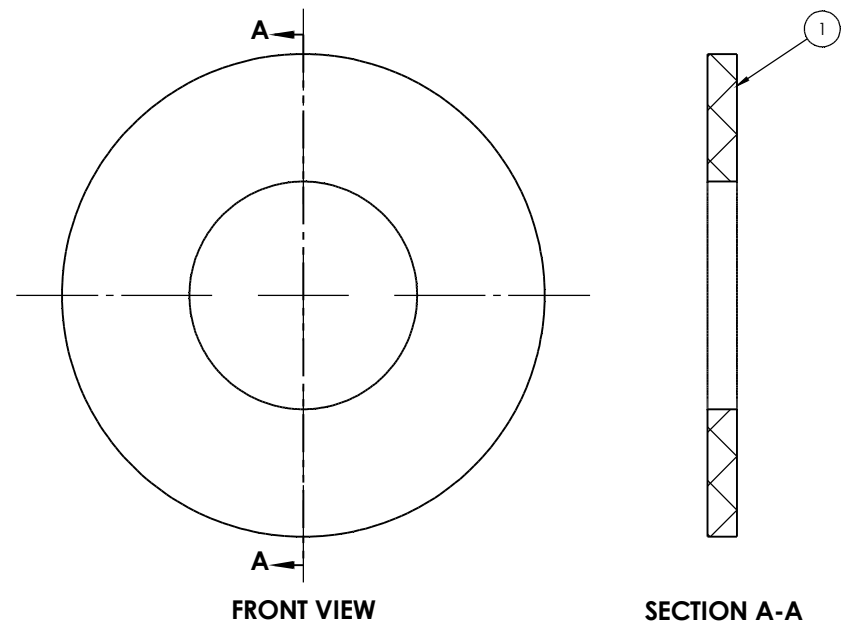

NOTES:

- PARTS ARE NOT SHIPPED ASSEMBLED.
- ALL DIMENSIONS ARE IN INCHES.
- DO NOT SCALE THIS DRAWING. WORK TO DIMENSIONS SPECIFIED.
- TOLERANCES FOR ALL DIMENSIONS SHALL BE NONCUMULATIVE.
- INTERPRET DRAWING IN ACCORDANCE WITH ASME Y14.5M.

DO NOT SCALE THIS DRAWING. WORK TO DIMENSIONS SPECIFIED.
 UNLESS SHOWN OTHERWISE, MACHINE TOLERANCES ARE:
 LINEAR UP TO 20" (0.5m) ± 0.020 (± 0.5 mm)
 OVER 20" (0.5m) ± 0.040 (± 1.0 mm)
 ANGULAR: $\pm 0.25^\circ$
 SURFACE FINISH: 125 μ inch Ra (3.2 μ m)
 MATERIAL SURFACE FINISH TO BE DETERMINED ONLY BY USE OF COMPARATOR

INITIAL APPROVAL & RELEASE		
NAME	SIGN	DATE
DRAWN J. PATINO	J.P.	04-OCT-2019
ENG. CHECKED N. CHOO-SON	N.C.	02-DEC-2019
MFG. CHECKED -	-	-
QUALITY CHECKED -	-	-
APPROVED E. MUJENZ	E.M.	02-DEC-2019

MARSH BROTHERS AVIATION
 BURLINGTON, ONTARIO, CANADA

THIS DRAWING IS THE PROPERTY OF MARSH BROTHERS AVIATION. ALL USE IS STRICTLY PROHIBITED WITHOUT PRIOR WRITTEN CONSENT.
 CET DESSIN EST DE PROPRIETE DE MARSH BROTHERS AVIATION. TOUTE USAGE C'EST STRICTEMENT INTERDIT SAUF PERMSSION ECRIT PRECEDENT.

PLATFORM: GENERAL	INITIAL RELEASE DATE: 02-DEC-2019	MRP NO. -	SIZE B	REV. A
TITLE/TITRE KIT, FUEL CAP - WASHER			DRAWING NO. DU DESSIN M-00-1002	REV. A
SHEET FEUILLE			1 OF DE	1