

INSTALLATION INSTRUCTIONS

DATE: January 17, 2022

PRODUCT: Aircraft Models Per Approved Model List (AML)

SUBJECT: Brake Master Cylinder Seal Kit Installation

PREPARED BY: E. Muenz

RELEASED BY:  02/03/22.



TRANSPORT CANADA
DESIGN APPROVAL ORGANIZATION
NO.: 17-C-01

APPROVED

By:  API

Appr'l Date: 14 Mar 2022

Appr'l No.: C-RA22-016/D

Issue No.: 1

REVISION HISTORY TABLE

Revision	Revision Date	By
NC	January 17, 2022	E. Muenz

	INSTALLATION INSTRUCTIONS BRAKE MASTER CYLINDER SEAL KIT INSTALLATION	Marsh Brothers Aviation Inc. II-M21002-1
---	--	---

INTRODUCTION

The purpose of these installation instructions is to provide all necessary information required to install a replacement seal kit in a brake master cylinder. The seal kit repairs a leaking brake master cylinder and provides preventative maintenance with a longer lasting lip seal.

APPLICABILITY

These installation instructions are applicable to the following aircraft, brake master cylinders, and seal kits:

AIRCRAFT	BRAKE MASTER CYLINDER P/N	SEAL KIT P/N
Aerostar Aircraft Corp.	980014-001 (MFG P/N: 10-24C)	M-00-1003
Mooney	10-24D	
Cirrus Design Corp.	14269-001 (MFG P/N: 10-24C)	

Aircraft applicability per Approved Model List (AML).

MATERIALS

a) Parts Required:

PART NUMBER	DESCRIPTION
M-00-1003	Seal Kit, Brake Master Cylinder, Cleveland

b) Tools Required:

- Standard aviation tools and consumables.

REFERENCES

1. AC43.13-2B – Acceptable Methods, Techniques, and Practices – Aircraft Alterations.
2. Refer to the applicable aircraft maintenance manual (AMM).

	INSTALLATION INSTRUCTIONS BRAKE MASTER CYLINDER SEAL KIT INSTALLATION	Marsh Brothers Aviation Inc. II-M21002-1
---	--	---

INSTRUCTIONS

A. BRAKE MASTER CYLINDER REMOVAL PROCEDURE



NOTE

PREPARE THE AIRCRAFT FOR MAINTENANCE AND PERFORM ALL WORK IN ACCORDANCE WITH THE APPLICABLE AIRCRAFT MAINTENANCE MANUAL PROCEDURES AND STANDARD PRACTICES.



NOTE

FOLLOW ANY MANUFACTURER OR AMM INSTRUCTIONS / PROCEDURES FOR DISSASSEMBLY AND REASSEMBLY OF THE BRAKE MASTER CYLINDER AS REQUIRED AND AS APPLICABLE.

1. Remove the brake master cylinder from the aircraft.
2. Disassemble the brake master cylinder to gain access to the piston and seals.

B. SEAL KIT INSTALLATION PROCEDURE

PREAMBLE:

This section provides an overview of the contents of the MB Aviation seal kit, as well as a visual reference to key components of the kit. The AeroTough® polymer END GLAND is provided with the piston rod V-SEAL already installed in the internal seal groove of the END GLAND.

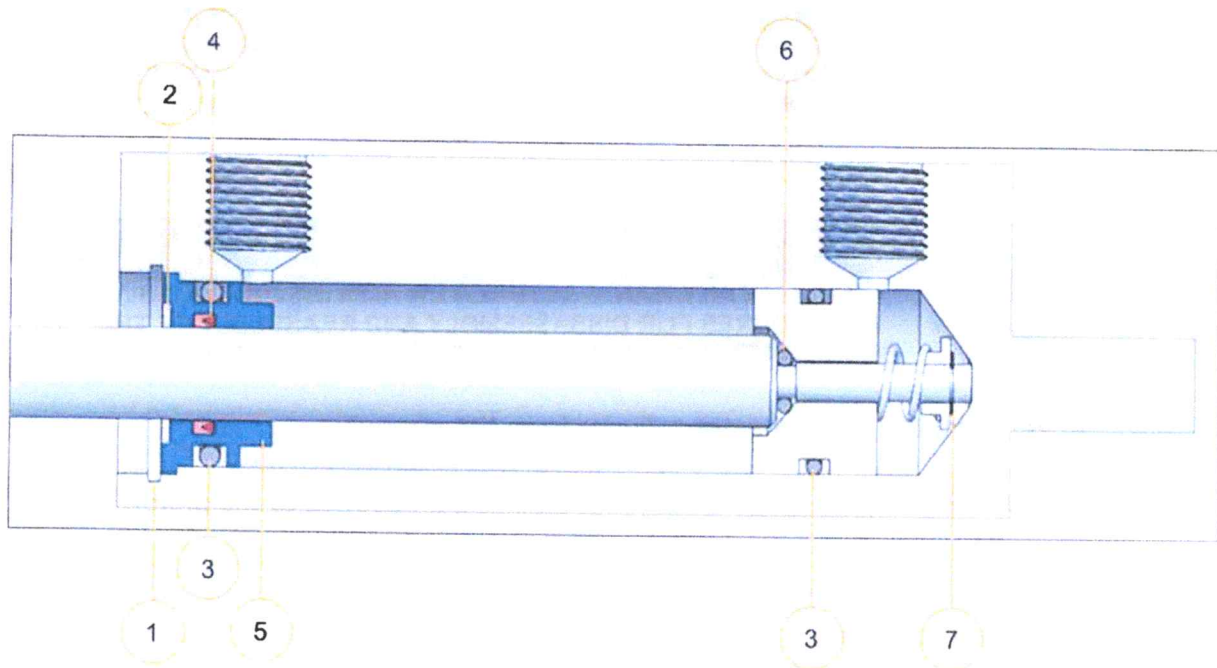

Note: Clevis, Jam Nut, Star Lock Washer, Flat Washer and Return Spring are omitted for clarity

ITEM NO.	PART NO.	DESCRIPTION	COMMENTS
1	MS16625-4081	Internal Retaining Ring	
2	MBA-01-10025	Spring Seat/Wiper Washer	Replaces OEM Nylon washer
3	MS28775-113	O-Ring (Piston Head, Gland Static)	
4	MBA-01-10021	Lip Seal (Piston Rod, Dynamic)	Replaces OEM O-ring
5	MBA-01-10022	End Gland	Replaces OEM aluminum gland
6	MS28775-006	O-Ring (Piston Head Bypass)	
7	T5304-015	Snap Ring	Piston head retainer
n/a	MS35333-40	Star Lock Washer	Clevis retaining hardware (Omitted for clarity)
n/a	AN960-616L	Flat Washer	
n/a	AN316-4	Nut	



CAUTION

DO NOT ATTEMPT TO INSERT PISTON ROD INTO END GLAND WITHOUT USE OF THE INSTALLATION TOOL.



FIGURE 1a
AeroTough® Polymer End Gland,
viewed from outer face.
(Spring Seat Washer and static
O-ring omitted for clarity)



FIGURE 1b
AeroTough® Polymer End
Gland, viewed from inner face.



FIGURE 1c
End Gland shown with AeroLas™-White
polymer Spring Seat Washer installed in
retaining groove.



NOTE

MB AVIATION MAKES AVAILABLE THE FOLLOWING TOOL TO AID IN THE INSTALLATION OF THE PISTON ROD WITHOUT DAMAGING THE NEW V-SEAL



CAUTION

DAMAGE TO THE PISTON ROD SEAL MAY OCCUR IF THE INSTALLATION TOOL IS NOT USED.

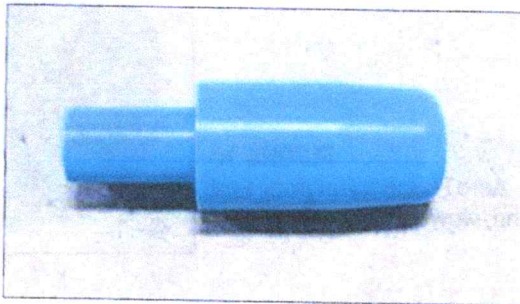

FIGURE 2 - INSTALLATION TOOL

Tapered nose used to expand V-seal to facilitate safe passage of piston rod.

INSTALLATION AND ASSEMBLY PROCESS:



CAUTION

ENSURE THAT WORK AREA, PISTON ROD, INSTALLATION TOOL AND END GLAND ARE CLEAN AND FREE FROM DIRT AND DEBRIS.

The following assembly process is depicted incorporating the use of the recommended MB Aviation tooling.

The installation of the END GLAND and PISTON ROD may be accomplished by alternate means, using best shop practices, however using the MB Aviation installation tools is recommended.

STEP 1



CAUTION

RETURN SPRING IS UNDER COMPRESSION LOAD. CARE TO BE TAKEN WHEN REMOVING CLEVIS TO SLOWLY RELEASE SPRING LOAD.



NOTE

CLEVIS, JAM NUT, WASHERS AND RETURN SPRING MAY BE REMOVED BEFORE REMOVAL OF END GLAND.

- a) Disassemble brake master cylinder in accordance with maintenance manual requirements to remove END GLAND and PISTON ROD.

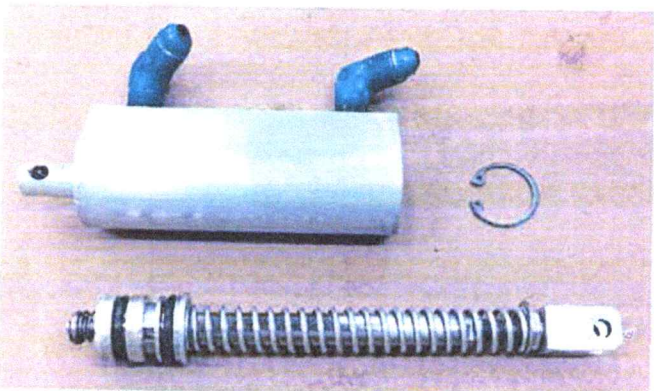

FIGURE 3
 Piston Rod assembly shown removed as a singled unit before removal of clevis, hardware, spring and End Gland.

- b) Remove and discard old PISTON HEAD O-ring, GLAND STATIC O-ring, SPRING SEAT WASHER, CLEVIS hardware (jam nut, star washer and flat washer)
- c) Clean PISTON ROD in accordance with maintenance manual requirements and standard practices.
- d) Visually examine PISTON ROD and PISTON HEAD to check for evidence of damage.
- e) Repair damage in accordance with maintenance manual requirements, as/if required.
- f) Install new PISTON HEAD O-RING.
- g) Arrange PISTON ROD and INSTALLATION TOOL as depicted in Figure 4 below.

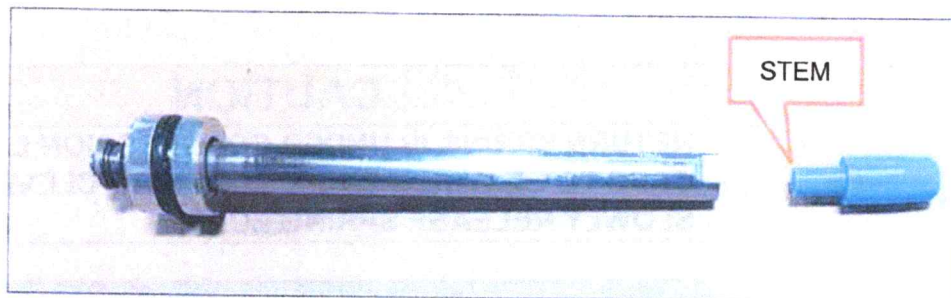



FIGURE 4 – PISTON ROD, INSTALLATION TOOL AND CUTAWAY END GLAND

- h) Insert stem of INSTALLATION TOOL into the threaded bore of the PISTON ROD.
- i) Ensure shoulder of the INSTALLATION TOOL is firmly seated against the end face of the PISTON ROD, as shown in Figure 5 below.



FIGURE 5 – PISTON ROD WITH INSTALLATION TOOL INSERTED

	INSTALLATION INSTRUCTIONS BRAKE MASTER CYLINDER SEAL KIT INSTALLATION	Marsh Brothers Aviation Inc. II-M21002-1
---	--	---

STEP 2

- a) Apply a thin film of hydraulic fluid to the INSTALLATION TOOL and the outer end of the PISTON ROD.
- b) Insert tapered end of INSTALLATION TOOL into END GLAND as shown in Figure.
- c) Once the INSTALLATION TOOL engages the seal (A), apply steady/firm pressure to push INSTALLATION TOOL and PISTON ROD all the way through END GLAND (B)

FIGURE 6 - PISTON ROD AND END GLAND DURING INSTALLATION
Engagement of the INSTALLATION TOOL with the SEAL will generally occur when the nose of the INSTALLATION TOOL begins to emerge from end face of END GLAND.

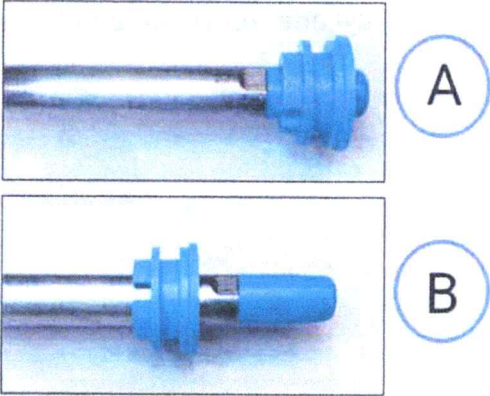

STEP 3

- a) Once the INSTALLATION TOOL and PISTON ROD end face have passed completely through the END GLAND, as shown in Figure 6 above, remove the INSTALLATION TOOL.
- b) Install new PISTON HEAD O-ring and GLAND STATIC O-ring.
- c) Install new AeroLas™-White SPRING SEAT WASHER into groove in END GLAND.
- d) Reinstall return spring, metal washers, jam nut and clevis and prepare brake master cylinder for re-assembly, as shown below in Figure 7

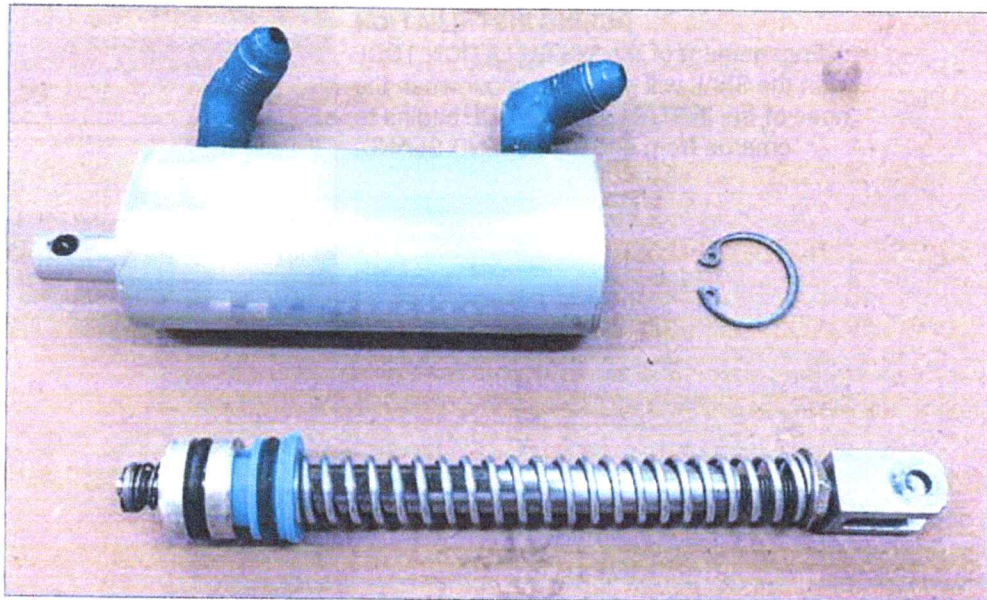

FIGURE 7 – REASSEMBLED BRAKE MASTER CYLINDER COMPONENTS READY FOR FINAL ASSEMBLY.

- e) Reinstall piston rod assembly into cylinder and firmly seat end gland into packing bore.
- f) Install new INTERNAL RETAINING RING provided in kit as shown in Figure 8.

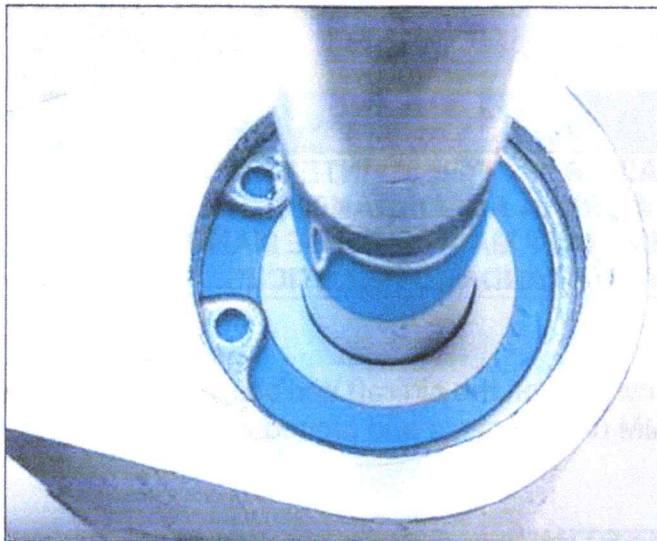

FIGURE 8 - FINAL INSTALLED GLAND
Internal Retaining Ring installed into
internal groove in cylinder packing bore.
(RETURN SPRING omitted for clarity)

	INSTALLATION INSTRUCTIONS BRAKE MASTER CYLINDER SEAL KIT INSTALLATION	Marsh Brothers Aviation Inc. II-M21002-1
---	--	---

C. BRAKE MASTER CYLINDER RE-INSTALLATION PROCEDURE



NOTE

PREPARE THE AIRCRAFT FOR MAINTENANCE AND PERFORM ALL WORK IN ACCORDANCE WITH THE APPLICABLE AIRCRAFT MAINTENANCE MANUAL PROCEDURES AND STANDARD PRACTICES.

- a) Re-install the brake master cylinder on the aircraft and adjust in accordance with the specific aircraft model's AMM requirements and procedures.

D. CLOSEOUT AND TESTING

- a) Perform post installation check-out and test in accordance with MB Aviation production test procedure GTP-M21002-2.

-- END OF PROCEDURE --

Contact

For additional information regarding the installation, servicing or other general inquiries contact Marsh Brothers Aviation:

Marsh Brothers Aviation Inc.,
3225 Mainway,
Burlington, ON L7M 1A6

Tel: 1-800-263-6242

Email: info@marshbrothersaviation.com

Website: www.marshbrothersaviation.com