

CONICAL FERMENTER

Instructions

CONTENTS

WHAT'S IN THE BOX.....	P.1
ANATOMY/SCHEMATICS.....	P.2
FERMENTING WITH THE STANDARD FERMENTER.....	P.5
COLLECTING AND TRANSFERRING.....	P.8
CONTROLLED HEATING AND COOLING.....	P.11

PRODUCT NAME: CONICAL FERMENTER
Rated 12V  2.75A max
Power Adapter 100 - 240V ~ 50/60Hz
Made in China

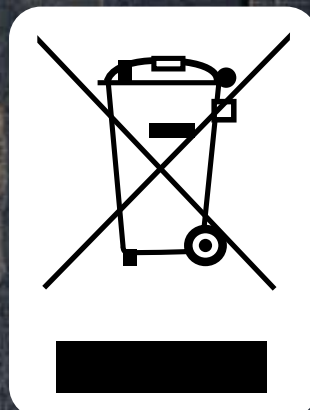

WHAT'S IN THE BOX?:

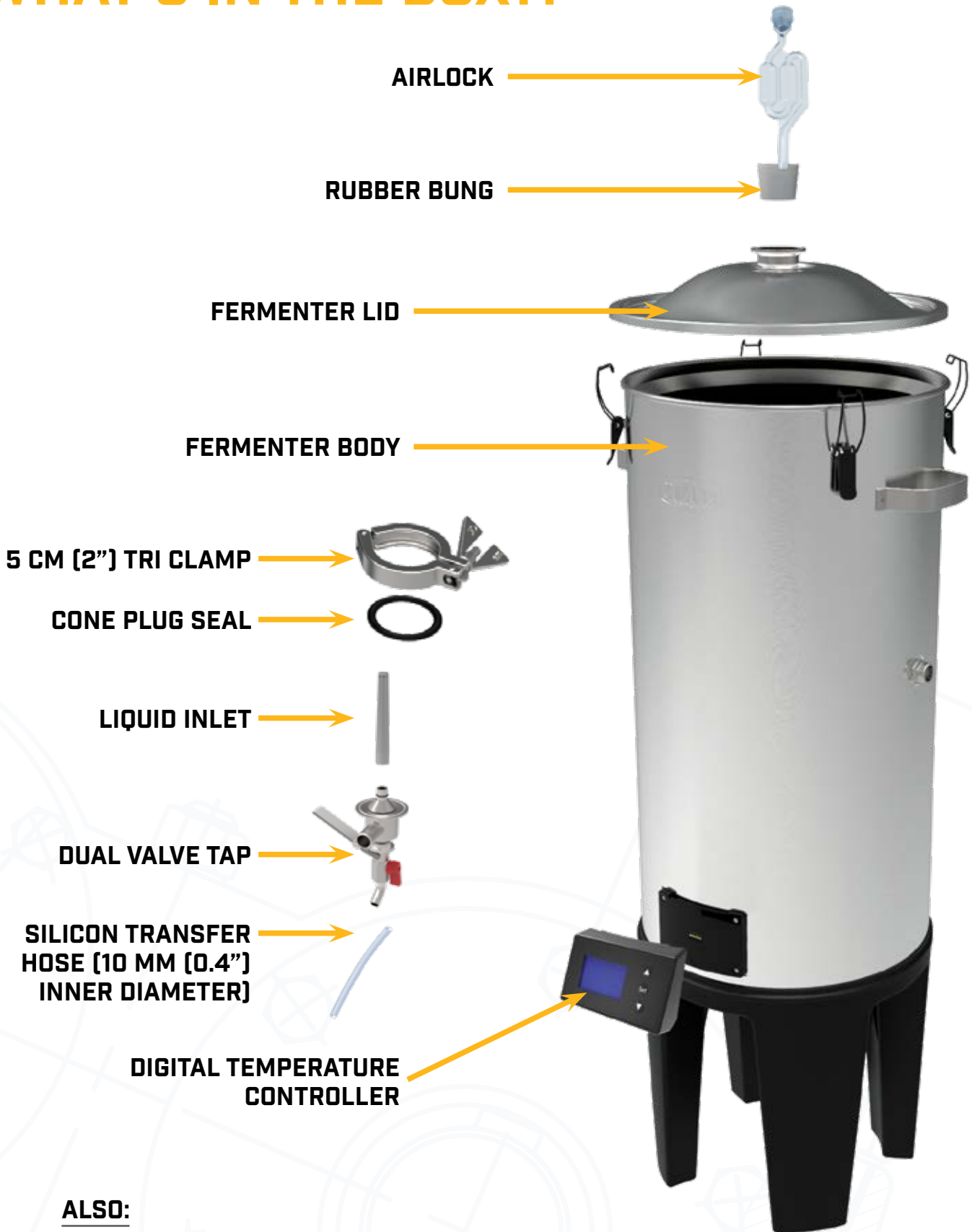

ALSO:

**POWER ADAPTER AND WALL PLUG
2 M (6.5 FT) M12-3PIN POWER CORD**



ANATOMY/ SCHEMATICS

1. Cooling connection coupler
2. Airlock
3. Rubber bung
4. Fermenter lid
5. Fermenter lid clips
6. Handle
7. Cooling sleeve connection
8. 304 stainless steel body
9. Controller mounting bracket
10. Digital temperature controller
(replace digital display with this controller)
11. Ferrule cone connection
12. Fermenter base
13. Dual valve tap
14. Cooling connection coupler
15. Fermenter power cord
16. Glycol chiller handle
17. Glycol chiller cap
18. Glycol chiller controls
19. Glycol chiller controller/display
20. Air cooling vents
21. 303 stainless steel casing
22. Castor steering wheels
23. Inline wheels



conical fermenter

fig. 1



glycol chiller

**FERMENT LIKE NEVER BEFORE.
THE GRAINFATHER CONICAL
FERMENTER GIVES THE BREWER
PROFESSIONAL FERMENTATION
CONTROL, JUST LIKE THE
COMMERCIAL BREWERIES.**

**FERMENTATION IS ARGUABLY THE MOST
IMPORTANT PART OF PRODUCING A GOOD
QUALITY BEER. A GOOD FERMENTATION
ENVIRONMENT HAS A CONSISTENT CONTROLLED
TEMPERATURE BASE, EXPOSURE TO OXYGEN IS
MINIMISED, AND THE FERMENTER IS CLEAN
AND STERILE.**

**THE GRAINFATHER CONICAL FERMENTER
PROVIDES YOU WITH A PROFESSIONAL QUALITY
SYSTEM FOR ALL OF THIS AND MORE.**

FERMENTING WITH THE CONICAL FERMENTER

SAFETY INFORMATION

1. Read all instructions before use.
2. Do not touch hot surfaces. Use handles or knobs.
3. To protect against fire, electric shock and injury to persons, do not immerse cord or plugs in water or other liquid.
4. Close supervision is necessary when any appliance is used by or near children.
5. Unplug from outlet when not in use and before cleaning. Allow to cool before putting on or taking off parts, and before cleaning the appliance.
6. Do not operate any appliance with a damaged cord or plug or if the appliance malfunctions, or has been damaged in any manner. Return appliance to your nearest retail service provider for examination, repair or adjustment.
7. The use of accessory attachments not recommended by the appliance manufacturer may result in fire, electric shock or injury to persons.
8. Do not use outdoors.
9. Do not let cord hang over edge of table or counter, or touch hot surfaces.
10. Do not place on or near a hot gas or electric burner, or in a heated oven.
11. Do not use the appliance for other than intended use.
12. Ensure that the main power supply to the controller contains overload protection (Maximum load: 230V/16A) in accordance with the related national and/or local codes.



SETUP & CLEANING

- Unpack the fermenter and all parts, remove the protective packaging.
- Assemble the valve and beer inlet and attach the valve to the bottom of the fermenter by inserting the ferrule seal, then using the tri clamp to tighten it. See page 9 for more information.

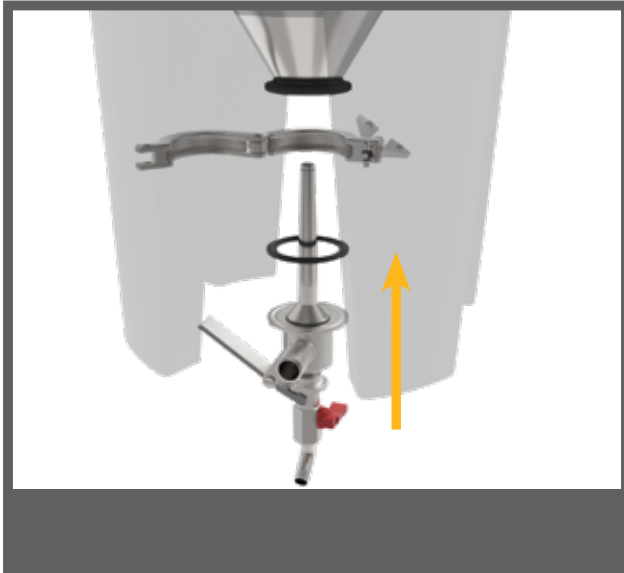

- Plug the 2 m (6.6 ft) power cord into the back of the fermenter.



- Plug the other end of this power cord into the power adapter, this then plugs into the wall, but do not switch the power on at the wall until you want to heat the fermenter.

- Attach the digital temperature controller by clipping it into the bracket on the front of the fermenter. A magnet will secure this.

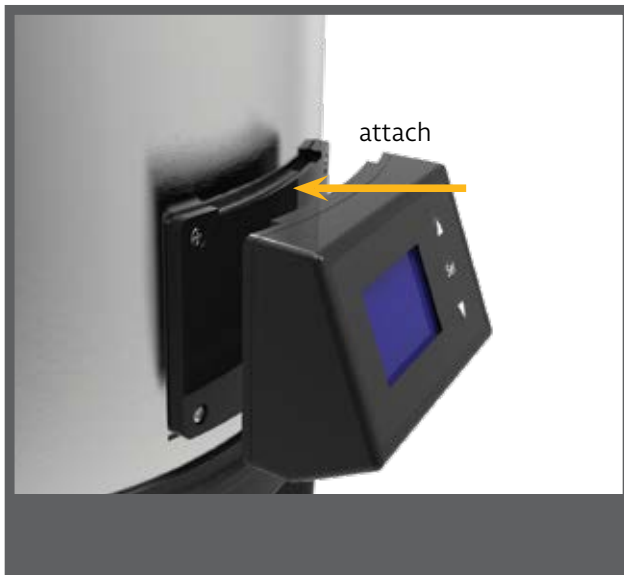

- Push the rubber bung into the hole in the fermenter lid. Then push the airlock into the holes in the rubber bung. This airlock is to stop anything from entering the fermenter during fermentation.
- Fill the fermenter halfway with water and add Mangrove Jack's Cold Water Cleaner Detergent.
- Scrub the sides of the fermenter and the lid with a non-abrasive cloth and clean water. Make sure to scrub all surfaces.
- Empty the water and rinse the fermenter with fresh clean water.
- Then use the Mangrove Jack's No Rinse Sanitiser.

USAGE

- Fill your fermenter as normal by syphon or counter flow wort chiller if using the Grainfather All in One Brewing System.
- Secure lid and ensure airlock is in place in the lid.
- Plug the fermenter in to power only when you are ready to heat.

For more on heating see p.11



COLLECTING & TRANSFERRING

ATTACHING AND USING THE DUAL VALVE TAP

INCLUDES:

- BOTTOM VALVE
- BEER INLET
- SILICON TRANSFER HOSE [10 MM (0.4") INNER DIAMETER]

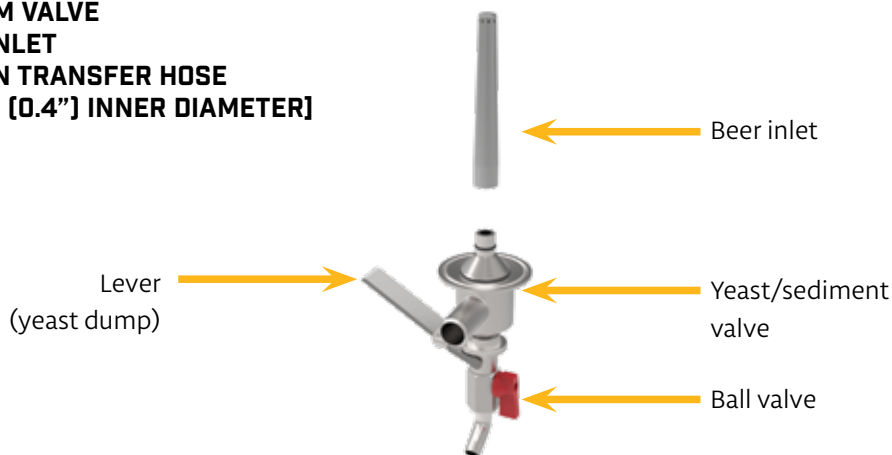

HOW DOES IT WORK?

The dual valve tap on the bottom of the fermenter uses a new innovative 'valve within a valve' design to allow you to both dump sediment from the beer, and take samples/transfer the beer. This is the first time a valve like this has been used in either of the homebrew or commercial areas.

- The large opening on the valve facing out at a 90 degree angle is where the yeast/sediment is removed. This opening is large enough to ensure none of the sediment 'clogs' it (provided the sediment is removed on a regular basis of 2-3 days). This part opens and closes with a spring loaded lever on the side of the valve to ensure minimal beer wastage.

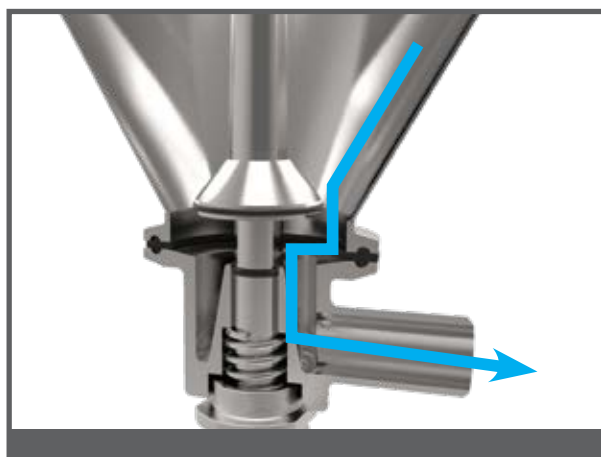

- The opening at the bottom is for taking beer samples while fermenting and also for transferring the beer once it has finished fermenting. This valve has a beer inlet piece that attaches to the top of it; this is where it takes the beer from. There are 2 different heights to select from.
 1. 110 mm - This is for most of the beers being made and is included in the valve.
 2. 160 mm - This is when using a lot of dry hops (200 g (7 oz) +) (sold separately).
- This beer inlet part is designed to sit above the yeast sediment so that it always takes a clean and clear sample.

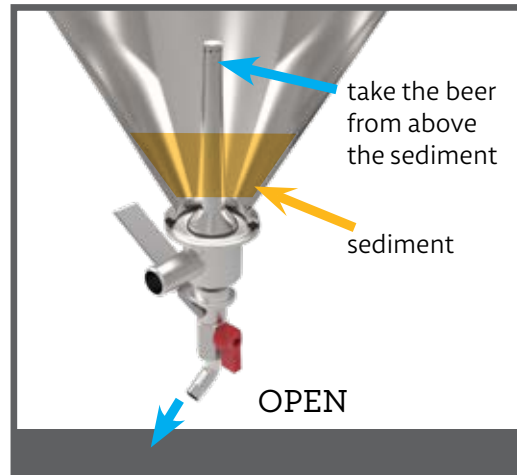
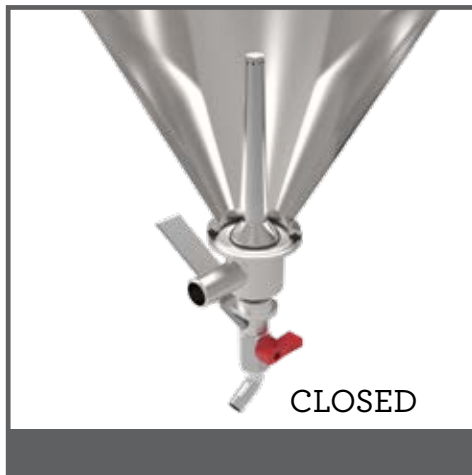

SETUP & CLEANING

- Assemble the valve and beer inlet and attach the valve to the bottom of the fermenter by inserting the ferrule seal, then using the tri clamp to tighten it.
- Fill the fermenter with some water and Mangrove Jack's Cleaner Detergent. Use the lever to open the "yeast dump" letting the water run through this to ensure all internal parts are clean. Do the same with the ball valve.
- Repeat with Mangrove Jack's No Rinse Sanitiser.

ASSEMBLY OF THE DUAL VALVE

For the purpose of cleaning and product maintenance



1. Push plug into shaft body



2. Attach spring



3. Screw on adapter



4. Screw on ball valve



5. Screw on sample tube



6. Attach liquid inlet

USAGE

It is good practice to dump dead yeast every 2-3 days during fermentation to prevent the yeast from clogging the valve.

1. To dump the yeast, open the yeast valve slowly. Collect the dead yeast and sediment in a vessel. Keep the valve open until the liquid coming out is clear before closing. You should usually dump about 300 ml (10 US fl oz).
 2. To harvest the yeast, it is best to take the final sample of yeast that you dumped after fermentation has finished.
- The beer valve can be used at any point during fermentation to collect samples to test the gravity of the beer. To do this, open the ball valve and collect the beer in an appropriate vessel.
 - The valve can also be used to transfer the beer after fermentation, simply by connecting a hose (10 mm (0.4") inner diameter) to the opening and opening the ball valve.
 - When adding dry hops, it is best to not dump the dry hops. Allow them to sit in the beer for as long as the recipe states, then transfer the beer.

NOTE: Always give the valve a good clean after fermentation. It is best to disassemble the parts and clean them, then reassemble. The entire valve can be disassembled for cleaning. Remember to sanitise before next use.



THE
GRAINFATHER
ALL GRAY BREWING

CONTROLLED HEATING & COOLING

In the cavity of the fermenter between the outer body and cone sits a 30W, 12V heating element. Unlike standard heating elements/sources that directly heat liquid, this is designed to heat the environment in between the double walls of the fermenter surrounding the liquid, which in turn heats the liquid. It is similar to controlling the temperature in a temperature controlled room. This way, the beer is not heating at a single small point, rather, it is evenly and gently heated and much better for the yeast.



In between the two stainless steel surfaces is a 10 mm (0.4") thick layer of polyurethane foam insulation. This is what keeps the liquid in the fermenter at a constant stable temperature that does not get influenced by any outside environmental changes.

The double insulated stainless steel walls provide three very important functions for heating and cooling.

1. It houses the cooling sleeve that glycol runs through to cool the liquid in the fermenter.
2. It provides a 'cavity' which when heated up creates an artificial environment so that the liquid in the fermenter can heat up gently without direct applied heat, in cold temperatures which is much better for the yeast.
3. It provides far superior insulation that cannot be achieved by a standard insulation jacket.

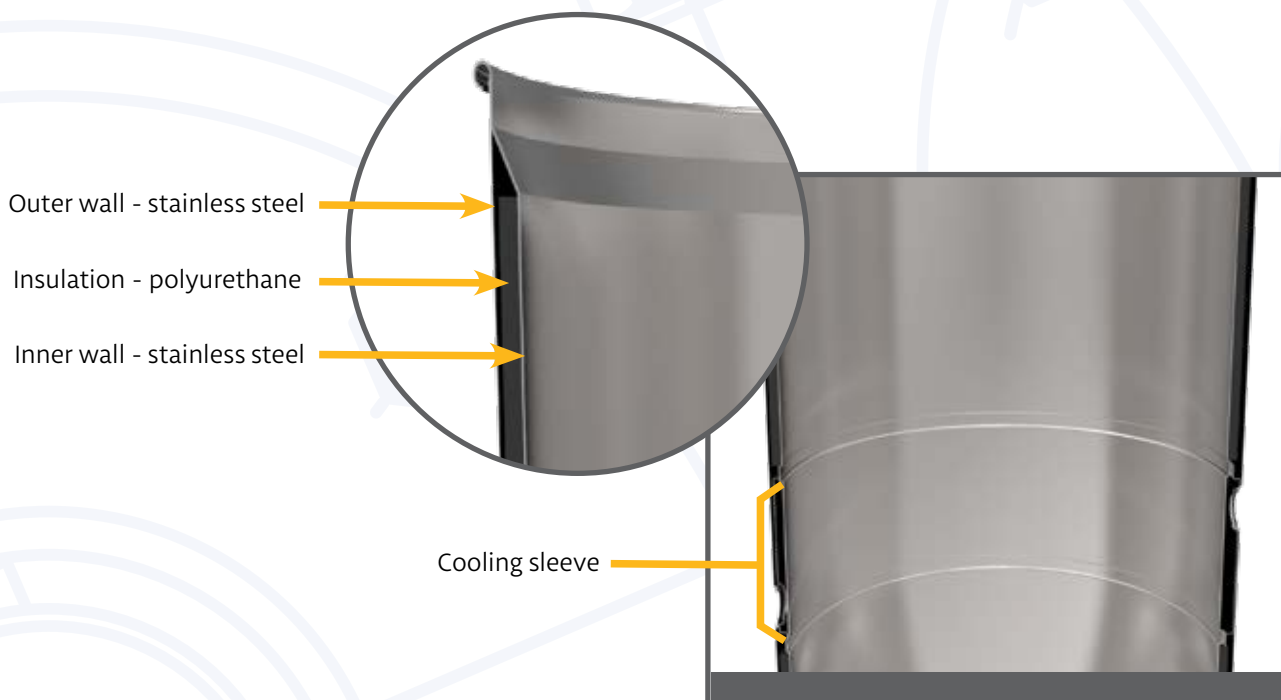

ATTACHING AND USING THE DIGITAL TEMPERATURE CONTROLLER

Easily snaps in place using magnets and pogo pins and allows you to accurately dial in a temperature, and even set a temperature schedule. Pogo pins are used as connections as well as a magnet. The controller is loaded with software that makes fermenting incredibly easy.

- Simply snap the controller into place onto the fermenter body.



- Set your temperature and schedule, eg heat the temperature to 18°C (64.4°F) and keep it there for 3 days. For setting a schedule and other options on the controller, see below.

MAIN/DEFAULT SCREEN

This screen shows the current temperature, target temperature, unit symbol (Celsius or Fahrenheit), current temperature control status (Heating/Cooling/Off), and, if there is currently a profile running, it displays the profile information.

On this screen you can do the following:

- Press up/down buttons to adjust the target temperature.
- Press the Set button to enter the menu.



MENU SCREEN

This screen shows the main menu options:

- Profiles (or Profile Options if a profile is running).
- Settings.

Here you can use the up/down buttons to move the cursor, and press the Set button to select an option.



SETTINGS SCREEN

This is where you can adjust the settings parameter. Use up/down buttons to navigate to the setting you want to change, then press set to toggle to change. For the hysteresis, press Set to toggle to edit mode and it will start flashing, then use up/down buttons to change value, then press Set again to toggle to edit finish.



In Settings you have options for:

- Units available: Metric/Imperial.
- Hysteresis (margin of temperature variation allowed before the temperature control turns back on): 0.1-2.0°C (32.2-35.6°F) adjustment .
- Mode: Heat/Cool (default), Heat Only, Cool Only, Off.
- Auto Proceed: The global setting is YES by default. If set to NO, upon completion of each step, it would require you to manually proceed to the next step via the controller.

PROFILES SCREEN

The profile screen shows the 4 built-in profiles:



1. Ale - 2 step profile, set up with default ale profile values, and allows you to edit the time/temperature of each step and auto proceed for step 1.
2. Lager - 4 step profile, set up with default lager profile values, and allows you to edit the time and temperature of each step and has auto proceed option for steps 1-3.
3. Custom 1 - you can specify amount of steps (up to 5), edit all values as above.
4. Custom 2 - same as custom 1.



Any changes made to profiles or settings are stored to its memory and the controller will remember changes even if it is turned off and then on again.

In the profile screen, you can navigate to any of the profiles. If you press Set, it will give the option to either brew or edit the profile.



- If you select Brew, the controller will set the profile step 1 temperature and start the timer. If auto proceed is set to YES, once the timer is finished the controller will change the temperature to the next step and start the timer for the next step until all steps are complete. If the global auto proceed is set to NO, the controller will display the interaction screen when timer finishes and wait for user to manually proceed to the next step.



- If you select Edit, you will navigate through each step which will allow you to change the step values.



PROFILE OPTIONS SCREEN

If a profile is already running and you go to the Menu, there will be an option for Profile Options. This will allow you to cancel the profile, extend the current step time, or manually proceed to the next step.



GLYCOL CHILLER (SOLD SEPARATELY)

The Conical Fermenter Glycol Chiller fully integrates into the Conical Fermenter and Digital Temperature Controller, and gives you the ability to cold crash and lager.

The glycol chiller connects to the hidden stainless steel sleeve inside the double walled fermenter and runs glycol through it to cool the stainless steel and therefore your wort down to your dialed in temperature on your controller. You can connect up to four fermenters at once, and program in different temperatures and fermenting schedules for each.

The cooling sleeve has two holes, one on each side, glycol entry (lower hole) and exit (upper hole) points. Cooling connection couplers, which can be quickly connected and disconnected, allow the liquid glycol to travel in and out of the fermenter.

As the cooling sleeve never comes into contact with the wort/beer and is never seen by you, it is not something that needs to be cleaned or sanitised, meaning your beer is never compromised.

With the Glycol Chiller you are operating your system at the ultimate level and you are now able to crash cool and lager.



ACCESSORIES

Add these on at any stage while you build your brewery. We will be actively bringing out more of these helpful accessories to make your brew day that much more enjoyable.

1. PRESSURE TRANSFER

For a clean and simple way to transfer your beer without the need to lift the fermenter to perform a gravity fed transfer. If you're set up with CO₂ supply then use this and transfer through the bottom of the fermenter. This ensures less chance of oxygen entering the beer during transfer.

2. COOLING PUMP KIT

Control the fermentation temperature with cold water by pumping it through the double walled insulated sleeve of the Conical Fermenter. Contains a small submersible pump and cooling connection kit, including insulated hoses, to attach easily to the fermenter.

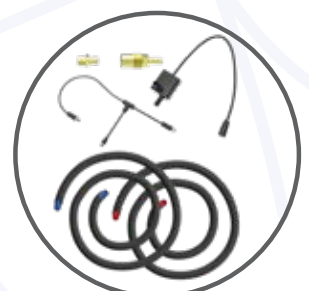

Reorder: 72663
Version: 2



www.grainfather.com