

Owner's Manual



RP-350.1D
RP-800.1D
RP-1200.1D
RP-1500.1D
RP-2000.1D
RP-3500.1D
RP-4500.1D
RP-75.4AB
RP-150.4AB
RP-600.5

High Performance Amplifiers

INTRODUCTION

Congratulations and thank you for purchasing Skar Audio amplifiers, the logical choice in mobile audio amplification. Your amplifiers have been designed and engineered with the highest quality components and top of the line workmanship to help you reach the superior sound you are after.

To achieve optimal performance of your system, please take a few moments to read over this Owner's manual or visit authorized dealer if needed before starting your installation.

DIGITAL MONOBLOCK FEATURES

- STABLE INTO 1 OHM LOAD
- HIGH SPEED MOSFET POWER SUPPLY
- 24dB/OCT, VARIABLE CROSSOVER
- VARIABLE LOW PASS FILTER
- VARIABLE SUBSONIC FILTER
- 6dB / 12dB SELECTABLE BASS BOOST
- REMOTE CONTROL
- COMPACT DESIGN

DIGITAL MONOBLOCK SPECIFICATIONS

	RP-350.1D	RP-800.1D	RP-1200.1D	RP-1500.1D	RP-2000.1D
Rated power output	RP-350.1D	RP-800.1D	RP-1200.1D	RP-1500.1D	RP-2000.1D
- RMS power @ 4 ohm	150Watts x 1	370Watts x 1	500Watts x 1	550Watts x 1	800Watts x 1
- RMS power @ 2 ohm	250Watts x 1	600Watts x 1	800Watts x 1	930Watts x 1	1400Watts x 1
- RMS power @ 1 ohm	350Watts x 1	800Watts x 1	1200Watts x 1	1500Watts x 1	2000Watts x 1
Working impedance	1 ohm stable	1 ohm stable	1 ohm stable	1 ohm stable	1 ohm stable
Input Sensitivity	6V ~ 0.2V	6V ~ 0.2V	6V ~ 0.2V	6V ~ 0.2V	6V ~ 0.2V
Low Pass Filter	50Hz ~ 220Hz	50Hz ~ 220Hz	50Hz ~ 220Hz	50Hz ~ 220Hz	50Hz ~ 220Hz
Subsonic Filter	Off ~ 50Hz	Off ~ 50Hz	Off ~ 50Hz	Off ~ 50Hz	Off ~ 50Hz
Bass Boost	6dB / 12dB	6dB / 12dB	6dB / 12dB	6dB / 12dB	6dB / 12dB
Frequency Response	20 ~ 250Hz	20 ~ 250Hz	20 ~ 250Hz	20 ~ 250Hz	20 ~ 250Hz
Signal to Noise Ratio	85 <	85 <	85 <	85 <	85 <
Efficiency @ 4ohm	Over 90%	Over 90%	Over 90%	Over 90%	Over 90%
THD @ 4ohm	< 0.1%	< 0.1%	< 0.1%	< 0.1%	< 0.1%
Damping Factor	150 <	150 <	150 <	150 <	150 <
Fuse Rating	30A	80A	100A	120A	200A
Dimensions (L inches)	6.23 inches	10.13 inches	11.81 inches	13.267 inches	17.71 inches
6.30 W x 2.20 H inches					

All features are subject to change in the continuing effort to improve the products without notice.

DIGITAL MONOBLOCK FEATURES

- STABLE INTO 1 OHM LOAD
- HIGH SPEED MOSFET POWER SUPPLY
- 24dB/OCT, VARIABLE SUBSONIC FILTER
- 24dB/OCT, LOW PASS FILTER
- VARIABLE BASS EQ
- VARIABLE PHASE CONTROL
- REMOTE CONTROL
- LINKABLE CONNECTION TO 2 OHM
- HIGH PURITY AND THICKNESS PRINTED CIRCUIT BOARDS (RP-3500.ID : 2oz, RP-4500.ID : 3oz)

DIGITAL MONOBLOCK SPECIFICATIONS

Rated power output	RP-3500.ID	RP-4500.ID
- RMS power @ 4 ohm	1200Watts x 1	1600Watts x 1
- RMS power @ 2 ohm	2300Watts x 1	2900Watts x 1
- RMS power @ 1 ohm	3500Watts x 1	4500Watts x 1
- RMS Strapped power @ 2ohm	7000Watts x 1	9000Watts x 1
Working impedance	1 ohm stable	1 ohm stable
Input Sensitivity	6V ~ 0.2V	6V ~ 0.2V
Low Pass Filter	35Hz ~ 250Hz	35Hz ~ 250Hz
Subsonic Filter	10Hz ~ 50Hz	10Hz ~ 50Hz
Bass EQ	0dB ~ 9dB	0dB ~ 9dB
Phase Control	0 ~ 180 Degree	0 ~ 180 Degree
Remote Control	Included	Included
Strapped Connection	Included	Included
Frequency Response	20 ~ 250Hz	20 ~ 250Hz
Signal to Noise Ratio	85 <	85 <
Efficiency @ 4ohm	Over 90%	Over 90%
THD @ 4ohm	< 0.1%	< 0.1%
Damping Factor	200 <	200 <
Fuse Rating	350A	450A
Strapped Fuse Rating	700A	900A
Dimensions (L inches)	18.90 inches	22.05 inches
8.27 W x 2.44 H inches		

All features are subject to change in the continuing effort to improve the products without notice.

MULTI-CHANNEL FEATURES

4 CHANNEL AMPLIFIER

- STABLE INTO 2 OHM STEREO OR 4 OHM MONO
- HIGH SPEED MOSFET POWER SUPPLY
- 12dB/OCT, HIGH PASS FILTER
- 12dB/OCT, LOW PASS FILTER
- 6dB / 12dB SELECTABLE BASS BOOST
- BAND-PASS CAPABLE
- SURFACE MOUNT TECHNOLOGY
- DOUBLE SIDED PRINTED CIRCUIT BOARD

5 CHANNEL AMPLIFIER

- CH1 ~ CH4 STABLE INTO 2 OHM STEREO
- CH5 STABLE INTO 1 OHM
- 12dB/OCT, HIGH PASS FILTER FOR CH1 ~ CH4
- 24DB/OCT, LOW PASS FILTER FOR CH5
- 24DB/OCT, SUBSONIC FILTER FOR CH5
- VARIABLE BASS BOOST
- SURFACE MOUNT TECHNOLOGY
- DOUBLE SIDED PRINTED CIRCUIT BOARD

MULTI-CHANNEL SPECIFICATIONS

Rated power output	RP-75.4AB	RP-150.4AB	RP-600.5
- RMS power @ 4 ohm	75Watts x 4	150Watts x 4	60Watts x 4 + 170Watts x 1
- RMS power @ 2 ohm	115Watts x 4	250Watts x 4	90Watts x 4 + 270Watts x 1
- RMS power @ 1 ohm	na	na	370Watts x 1
- RMS power @ 4 ohm mono	250Watts x 2	500Watts x 2	180Watts x 2
Working impedance	2 ohm stable	2 ohm stable	2 ohm for CH1/4, 1 ohm for CH5
Input Sensitivity	6V ~ 0.2V	6V ~ 0.2V	6V ~ 0.2V
High Pass Filter	20Hz ~ 5KHz	20Hz ~ 5KHz	20Hz ~ 5KHz - CH1/2 & CH3/4
Low Pass Filter	50Hz ~ 500Hz	50Hz ~ 500Hz	50Hz ~ 250Hz for CH5
Subsonic Filter	na	na	10Hz ~ 50Hz for CH5
Bass Boost	6dB / 12dB	6dB / 12dB	0 ~ 12dB for CH5
Frequency Response	20Hz ~ 20KHz	20Hz ~ 20KHz	20Hz ~ 20KHz for CH1/4, 20 ~ 250Hz for CH5
Signal to Noise Ratio	105 <	105 <	105 < for CH1/4, 85 < for CH5
Efficiency @ 4ohm	Over 65%	Over 65%	Over 65% for CH1/4, Over 90% for CH5
THD @ 4ohm	< 0.1%	< 0.1%	< 0.1%
Damping Factor	150 <	150 <	150 <
Fuse Rating	60A	120A	80A
Dimensions (L inches)	13.78 inches	17.72 inches	16.93 inches
6.30 W x 2.20 H inches			

All features are subject to change in the continuing effort to improve the products without notice.

POWER CONNECTION

HEADUNIT

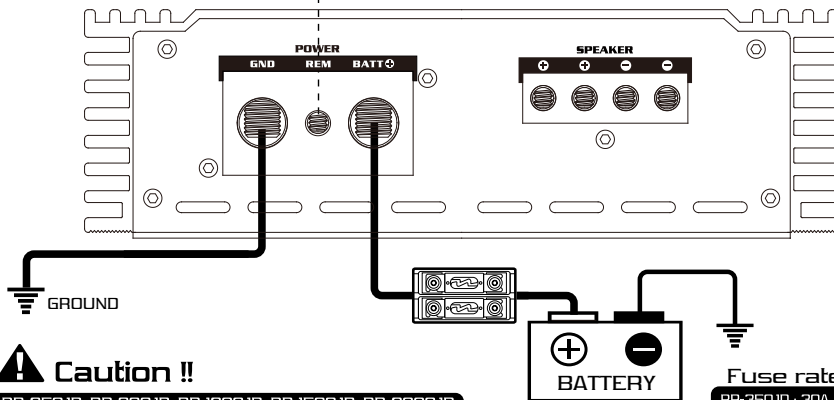

Caution !!

RP-350.1D, RP-600.1D, RP-1200.1D, RP-1500.1D, RP-2000.1D
 RP-3500.1D, RP-4500.1D, RP-75.4AB, RP-150.4AB
 & RP-600.5 working voltage is 8.5V to 16Volts

Fuse rate

RP-350.1D : 30A
 RP-600.1D : 80A
 RP-1200.1D : 100A
 RP-1500.1D : 120A
 RP-2000.1D : 200A
 RP-3500.1D : 350A
 RP-4500.1D : 450A
 RP-75.4AB : 60A
 RP-150.4AB : 120A
 RP-600.5 : 80A

BATT + (+12V POWER)

Before mounting amplifiers, disconnect the negative cable from the battery to protect any accidental damage to your amplifiers and audio system.

RP-2000.ID, RP-3500.ID & RP-4500.ID are designed to use 0 ga power and ground connection. Rest of RP amplifiers are designed to use 4 gauge power and ground connection.

Connect the power cables to power terminal +12V.

All RP-series amplifiers are not equipped with fuses so that external fuses should be used.

Connect one end of fuse holder to the power cable going into the amplifiers and the other end of fuse holder to positive battery. This fuse location will protect the system and the vehicle against the possibility of a short circuit in the power cable.

Be sure to use fuses and fuse holder adequate for the application.

GND (GROUND)

Locate a secure grounding connection as close to amplifier as possible.

Make sure the location is clean and provides a direct electrical connection to the frame of the vehicle. The ground needs to have as low of a resistance as possible.

Connect one end of a short piece of the same size cable as the power cable to the grounding point or to one of your batteries or battery bank. Run the other end of 4 ga cable to the mounting location of the amplifiers for connection to the amplifiers ground terminals and connect the ground cable to the GND (ground terminal).

REM (REMOTE)

Run a remote turn on cable from the switched +12V source . This may be a toggle switch, a relay, your source unit's remote trigger cables, or power antenna trigger cable.

Connect the remote turn on cable to the REM (remote) terminal.

DIGITAL MONOBLOCK INPUT CONNECTION

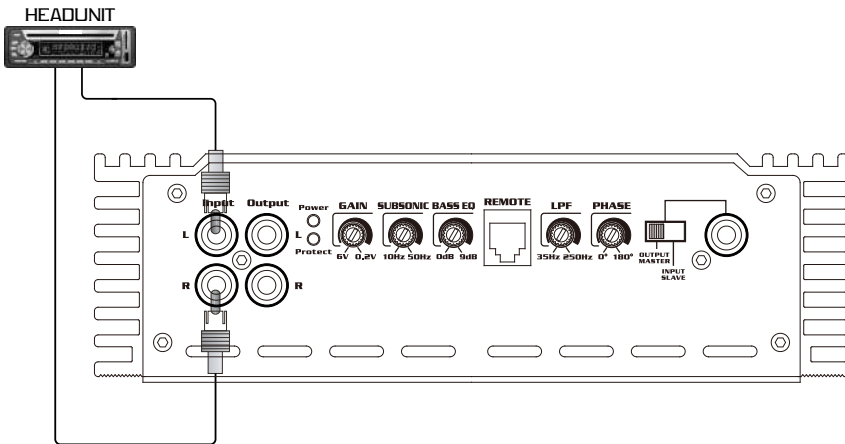

DIGITAL MONOBLOCK SPEAKER CONNECTION

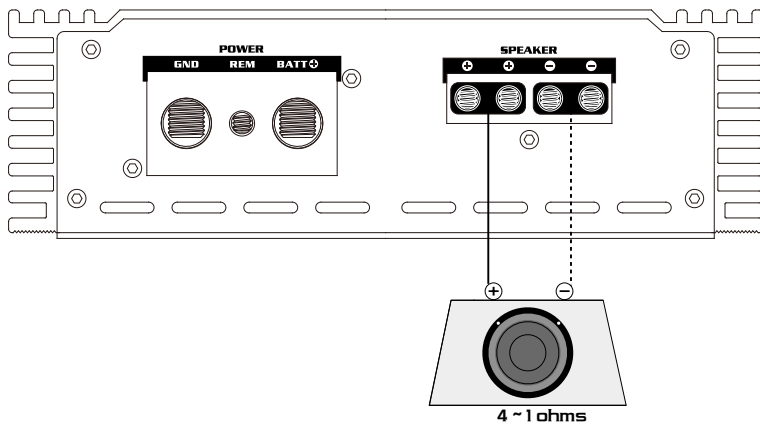

! Caution !!

RP-series Digital Monoblock's minimum working impedance is 1ohm

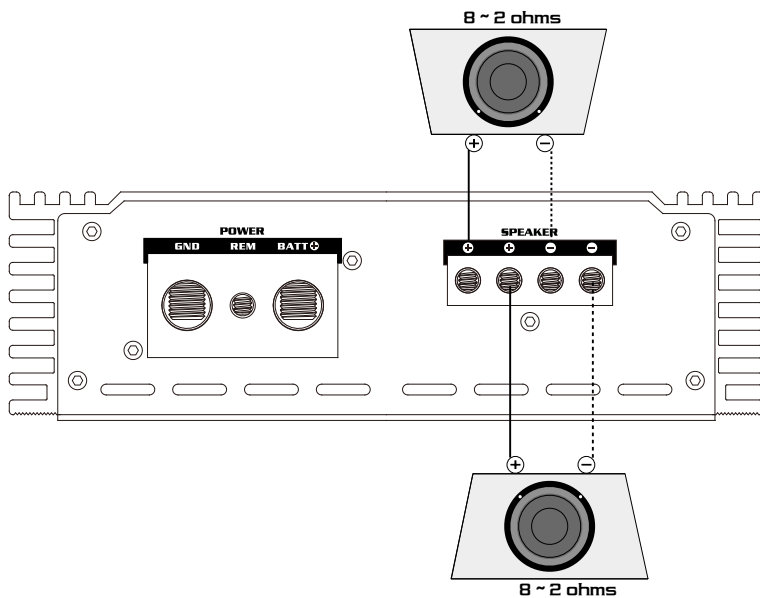

STRAPPABLE CONNECTION

Strappable connection makes two of same amplifiers strapped to 2 ohm.
Strappable connection makes the power double than their 1 ohm power.
Please read the following connection and diagram carefully to make correct connection.

INPUT CONNECTION :

Step 1. Connect the Master amplifier to the head-unit and set its output master / input slave switch to output master.

Step 2. Set Slave amplifier output master / input slave switch to slave input.

Step 3. Connect RCA cable from the master to slave amplifier as shown in the diagram.

POWER & SPEAKER CONNECTION :

Step 1. Connect speaker cable (+) on master amplifier to subwoofer (+)

Step 2. Connect speaker cable (+) on slave amplifier to subwoofer (-)

Step 3. Connect speaker cable (-) on master amplifier to speaker cable (-) on slave amplifier

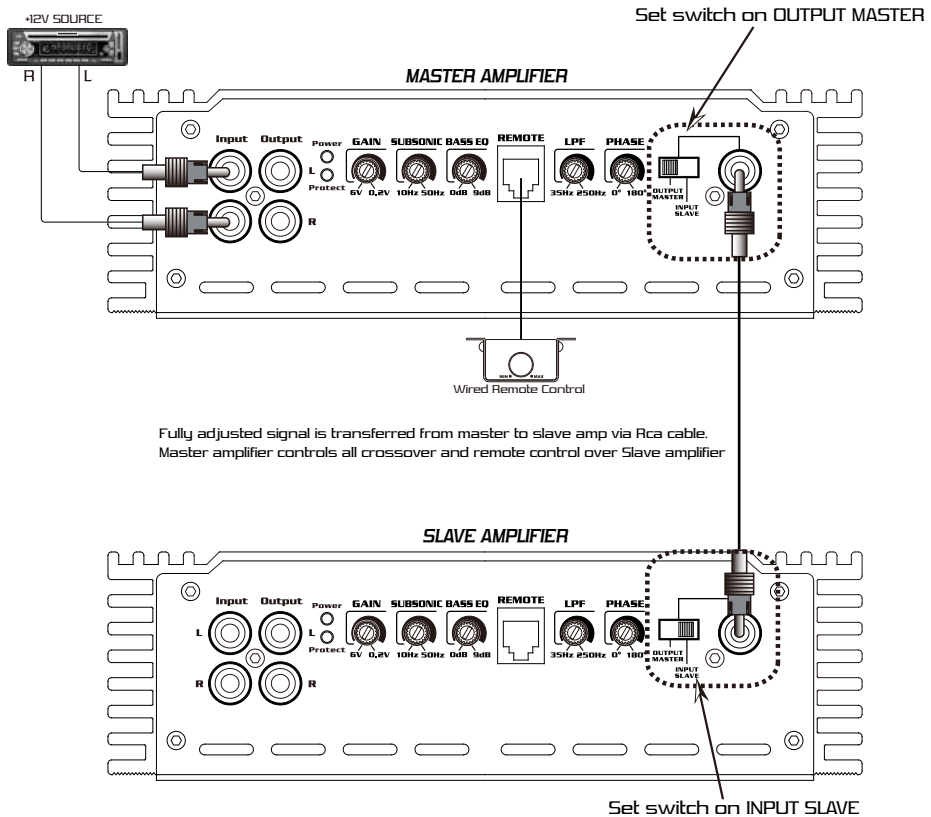

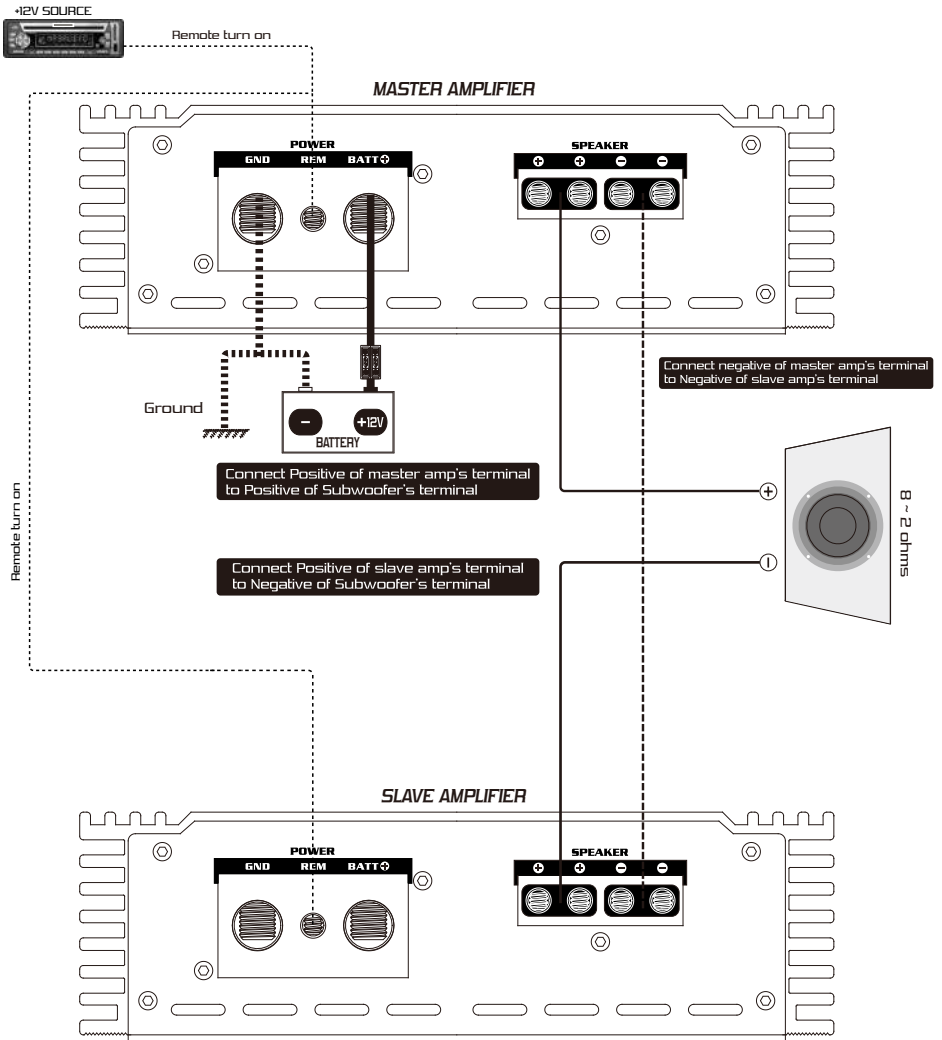

! Caution !!

In strappable connection,

Minimum working impedance is 2 ohm.
Impedance lower than 2 ohm can damage the amplifiers

All RP-monoblock minimum working voltage is 8.5V to 16Volts.

4 CHANNELS RCA INPUT CONNECTION

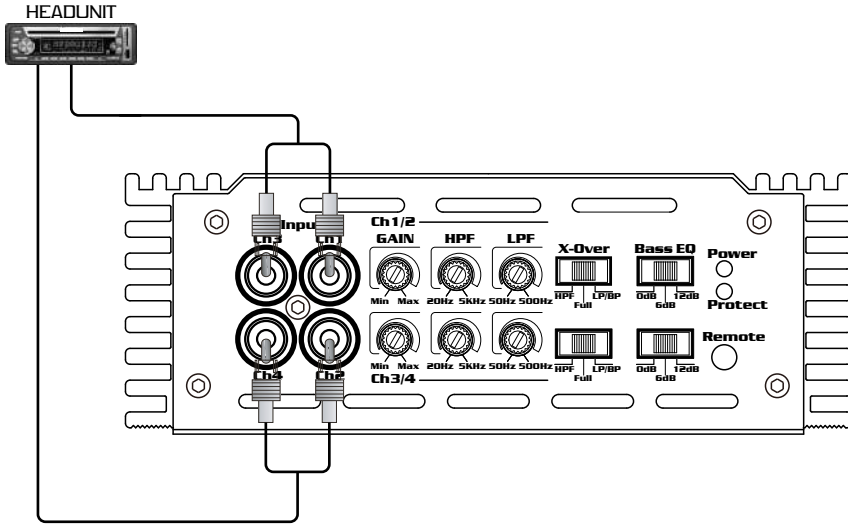

4 CHANNELS SPEAKER CONNECTIONS

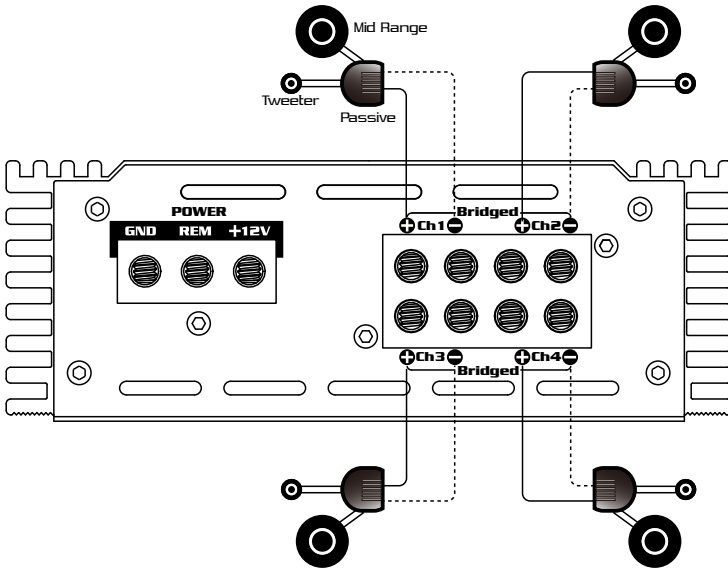

! Caution !!

RP-75.4AB & RP150.4AB minimum working impedance is 2 ohm stereo or 4 ohm mono.

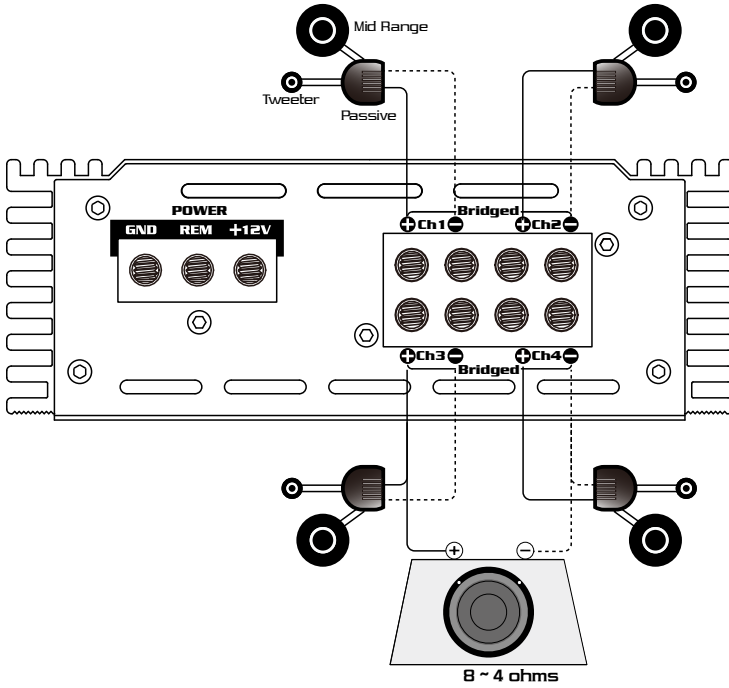

5 CHANNEL RCA INPUT CONNECTION

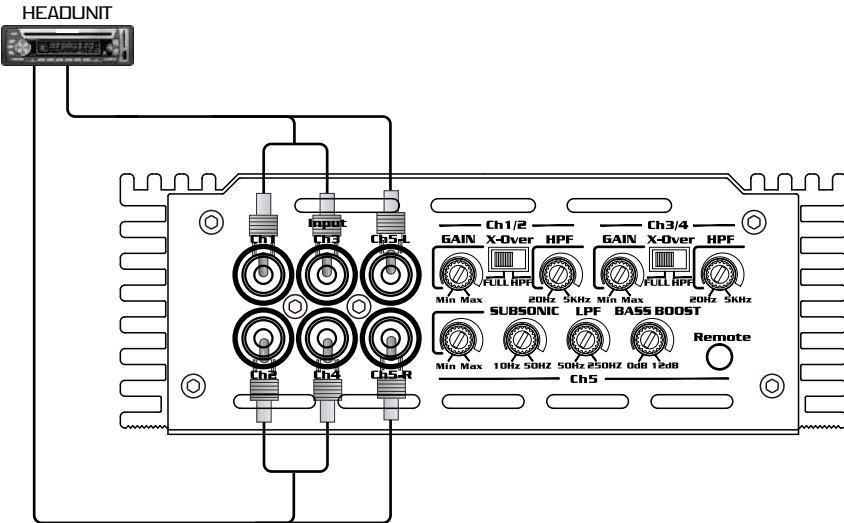

5 CHANNEL SPEAKER CONNECTIONS

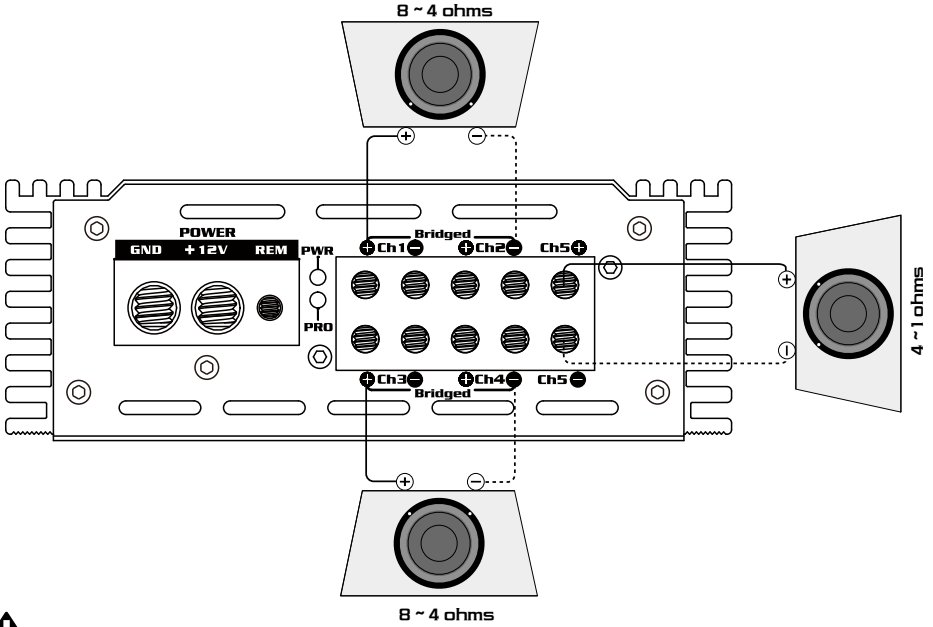

! Caution !!

RP-600.5 minimum working impedance is 2 ohm stereo or 4 ohm mono for Ch1 ~ Ch4 and 1 ohm for Ch5

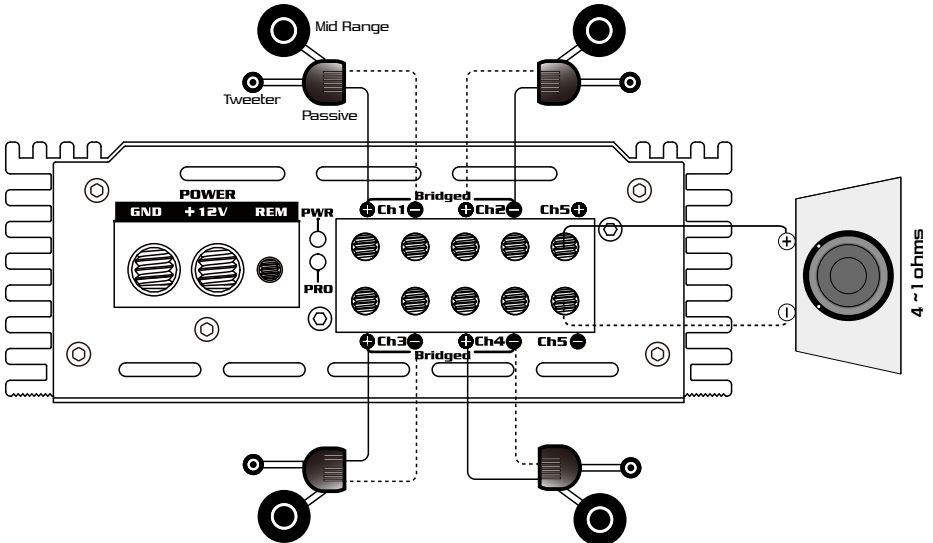

TROUBLE SHOOTINGS

RP-series amplifiers have protection features to prevent any damages from misuse or faulty conditions.

If RP-series amplifiers sense excessive heat, short circuited speakers DC, or voltage the protection indicator will light, and the system will be turned off.

In order to check the problem, you should turn all levels down and all power off and carefully check the installation for wiring mistakes or short.

If RP-series amplifiers shuts down due to excessive heat. They will be working later when it is cooled down

Before removing your amplifier, refer to the list below and follow the suggested procedures.

NO SOUND (NO OUTPUT)

- Ⓜ Please check all connections, cables' routing, short & voltage.
- Ⓜ Please check the fuses . If they are blown, please replace with new one..
- Ⓜ Please check whether speakers work well. you can test speakers by connecting to another amplifier

PROTECTION

- Ⓜ Please check overload, overheat (thermal), short and voltage, DC offset.
- Ⓜ Minimum working impedance is 1 ohm for RP-350.ID, RP-800.ID, RP-1200.ID, RP-1500.ID, RP-2000.ID, RP-3500.ID and RP-4500.ID.
RP-75.4AB and RP-150.4AB is 2 ohm stereo or 4 ohm mono.
RP-600.5 is 2 ohm stereo or 4 ohm mono for CH1 ~ CH4 and 1 ohm for CH5.
- Ⓜ If amplifiers are shut down due to heat, they will be on some minutes later after cooling down.
Please make better airflow and no obstruction around amplifiers for thermal protection.
- Ⓜ RP-350.ID, RP-800.ID, RP-1200.ID, RP-1500.ID, RP-2000.ID, RP-3500.ID, RP-4500.ID RP-75.4AB, RP-150.4AB & RP-600.5's working voltage is 8.5 ~ 16Volts.
- Ⓜ When over 4V DC comes into amplifiers, then, they will be DC protected. Check whether amplifiers work after removing RCA-Input.
If amplifiers work, then check DC by checking RCA-input .
When DC is over 4V at input, try by replacing +12V source unit .

DISTORTION & NOISE

- Ⓜ Readjust input level and check the speaker quality at another amplifier.
Replace poor quality speakers with good quality ones.
- Ⓜ Check amplifiers and headunit's ground contact. all grounds should be common.
- Ⓜ Check Rca Jack, then repalce with new one or reroute Rca Jack.
- Ⓜ Engine noise is caused by poor grounding of amplifiers, headunit, other components, battery or alternator, so please check all grounding connection.

POOR BASS RESPONSE

- Ⓜ Please check speaker cables and reverse polarity.

