



# Tri-Mode Tumblebox O&M Manual



**Air Side**

**Tri-Mode Valve  
Part #60-070-076**



**Water Side**

## **ADVANCED PRESSURE SYSTEMS**

701 S. Persimmon St., Suite 85 - Tomball, TX 77375

Toll Free in North America: (877) 290-4277

Phone: (281) 290-9950 Fax: (281) 290-9952

E-mail orders: [sales-team@waterblast.pro](mailto:sales-team@waterblast.pro)

[WWW.ADVANCEDPRESSURESYSTEMS.COM](http://WWW.ADVANCEDPRESSURESYSTEMS.COM)

[WWW.WATERBLAST.PRO](http://WWW.WATERBLAST.PRO)

**YOU ARE RESPONSIBLE FOR SAFETY!**

Advanced Pressure Systems publishes guides for the safe use of Water Blasting Equipment.

**Please READ them!**

We also strongly advise that all personnel are fully conversant with:

***"Recommended Practices for the Use of Manually Operated High Pressure Water Jetting Equipment"***  
published by the Water Jet Technology Association.



These may be obtained free of charge by contacting:  
**ADVANCED PRESSURE SYSTEMS, L.P. (877) 290-4277**

### Conditions of Sale & Warranty

**General** - These terms and conditions and warranty provisions are applicable to all products contained in this catalog, and may not be varied, except in writing by a partner of APS Pressure Systems L.P.

**Terms of Sale –**

- 1) All sales are FOB manufacturers plant, Houston, Texas, and are priced and must be paid for in US dollars.
- 2) The purchaser agrees to hold APS Pressure Systems (DBA: Advanced Pressure Systems) harmless for any and all claims arising from the misuse or misapplication of any product manufactured or supplied by Advanced Pressure Systems.
- 3) Products returned for credit will be subject to 15% restocking charge. Only standard products will be accepted for restocking. All sales of non-standard items are final.
- 4) Payment may be made by credit cards issued by VISA or MASTERCARD. Payment by credit cards issued by AMERICAN EXPRESS will be subject to 3% service charge.

**Warranty** - The following classes of products carry the warranty indicated. Any component included in an assembled product which is subject to wear is not warranted. Products which have been subject to abuse including misapplication, corrosion, excessive pressure, over-tightening and galling of screw threads will not be accepted for replacement under warranty. Products not manufactured by Advanced Pressure Systems will carry the warranty by of the respective manufacturer

**Hose** - Not warranted. Coupling may be warranted by manufacturer.

**Rigid Lances** - Ninety days from date of shipment.

**Plungers and Pump Packing** - Not warranted.

**Control Guns, Flow Divider Valves, Flow Control Valves** - Ninety days from date of shipment.

**Relief Valves** - 180 days from date of shipment.

**Nozzles and nozzle inserts / orifices** - Not warranted

**Fittings, Connectors and Couplings** - 180 days from date of shipment.

**Shipping Costs** - Orders may be shipped prepaid by any regularly available means, and the cost will be paid by the customer. Other shipping costs including but not limited to: insurance for the full retail value of the products, packaging, crating and any other handling costs will be billed to the customer. If the customer collects the products from the Houston plant there will not be any shipping charges.

**Payment** - All invoices are due net 30 days from date of shipment. Any invoices which are more than 30 days past due will result in the account of the customer concerned to be placed on hold.

***One Direct Source for all your  
Water Blasting Parts and Accessories!***

<b>SECTION</b>	<b>CONTENTS</b>	<b>PAGE</b>
1	Description of the APS Tri-Mode Tumblebox	2
2	Parts List and Assembly Diagram of the Tri-Mode	3-6
3	Regular Maintenance of the Tri-Mode	7-8
4	Operating Specifications	9
5	Necessary Additional Equipment	9
6	How to Hook It Up	10
7	Connecting System Components	10-11
8	Safety Considerations	12
9	Risks Associated with the Use of this Equipment	12-13

## **Section 1**

### **Description of the APS Tri-Mode Valve(Tumblebox).**

The Advanced Pressure Systems (APS) “Tri-Mode” Flow Control Valve, commonly referred to as a “Tumble Box”, is the ON/OFF control device for the flow of Ultra High Pressure water to an APS Cobra Rotary Gun or similar control gun. It performs two functions which affect the gun. It controls and conditions the air flowing to the gun, maintaining the correct pressure and injecting lubricant for the air motor. It also turns the Ultra High Pressure water On and Off when the triggers of the gun are activated or released. Each rotary control gun requires a dedicated Tri-Mode Valve. *(The Tri-Mode Valve can be used to replace the Tumble Boxes of Gardner Denver, Jetstream and NLB).*

### **The 3 Modes of Operation:**

As the name suggests there are three configurations (modes) for operation of the Tri-Mode Valve.

#### **Mode 1 – Pressurized Dump Mode**

In this configuration, when the triggers of the rotary gun are released, all flow from the gun ceases and the Tri-Mode Valve diverts all of the high pressure flow through an orifice contained within the Energy Dissipater Assembly part of the valve. The orifice is sized to deliver a flow which is the same as that which is being delivered by the gun. The energy from this jet is destroyed within the Energy Dissipater and is dumped out of the elbow at the end of the Dissipater at low pressure. The Energy Dissipater Tube (Part No. 60-070-040) is a wear item, which is eroded by the high pressure jet and needs to be replaced periodically.

This Mode 1 configuration maintains the pressure in the system which is connected to the pump, and allows for the use of multiple guns with one pump.

#### **Mode 2 – Dry Shut-off Mode**

In this arrangement the Energy Dissipater Assembly is replaced with a plug, which requires that a flow compensation device is included in the system, usually the pump, which will divert the unused flow back to the water tank. This arrangement is primarily for use with an intensifier pump, which will operate best when the flow and pressure remain constant.

Mode 2, like Mode 1 described above, also maintains pressure in the system allowing for the use of more than one gun. It is essential to have a pressure compensator/un-loader device somewhere in the system to divert excess flow.

#### **Mode 3 – Low Pressure Dump Mode**

This configuration is for a single gun, operating with a plunger pump. Setting up this arrangement is simply a matter of omitting the orifice from the Energy Dissipater. When the triggers are released on the rotary gun (e.g. “APS Cobra”) the flow is discharged from the Tri-Mode valve directly to atmospheric pressure, which means the pressure will also be reduced to atmospheric in the entire system all the way back to the pump.

**Figure 1**

**Air Supply Side of the APS Tri-Mode Tumblebox.**

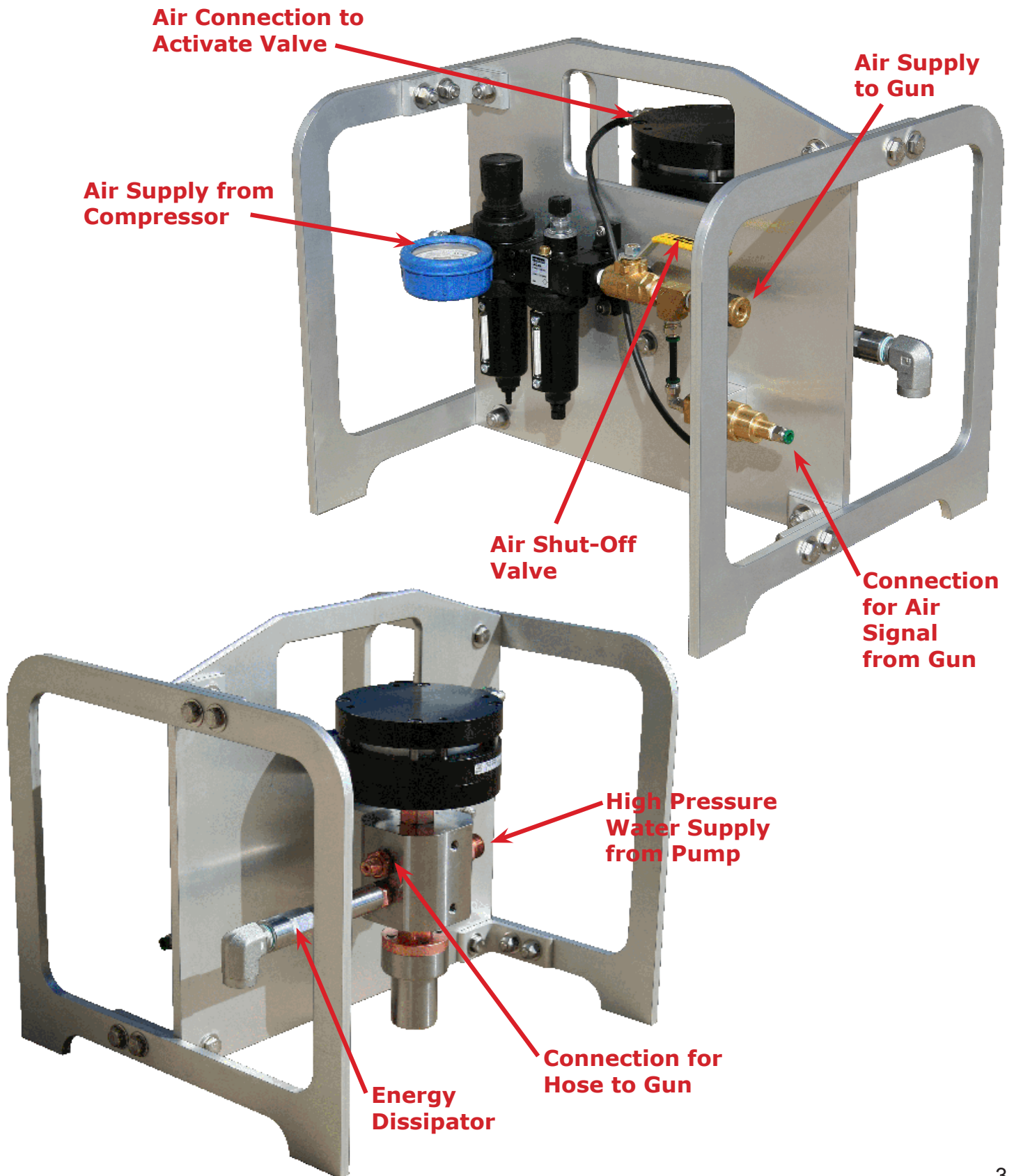

**Figure 2**

**Water Supply Side of the APS Tri-Mode Tumblebox.**

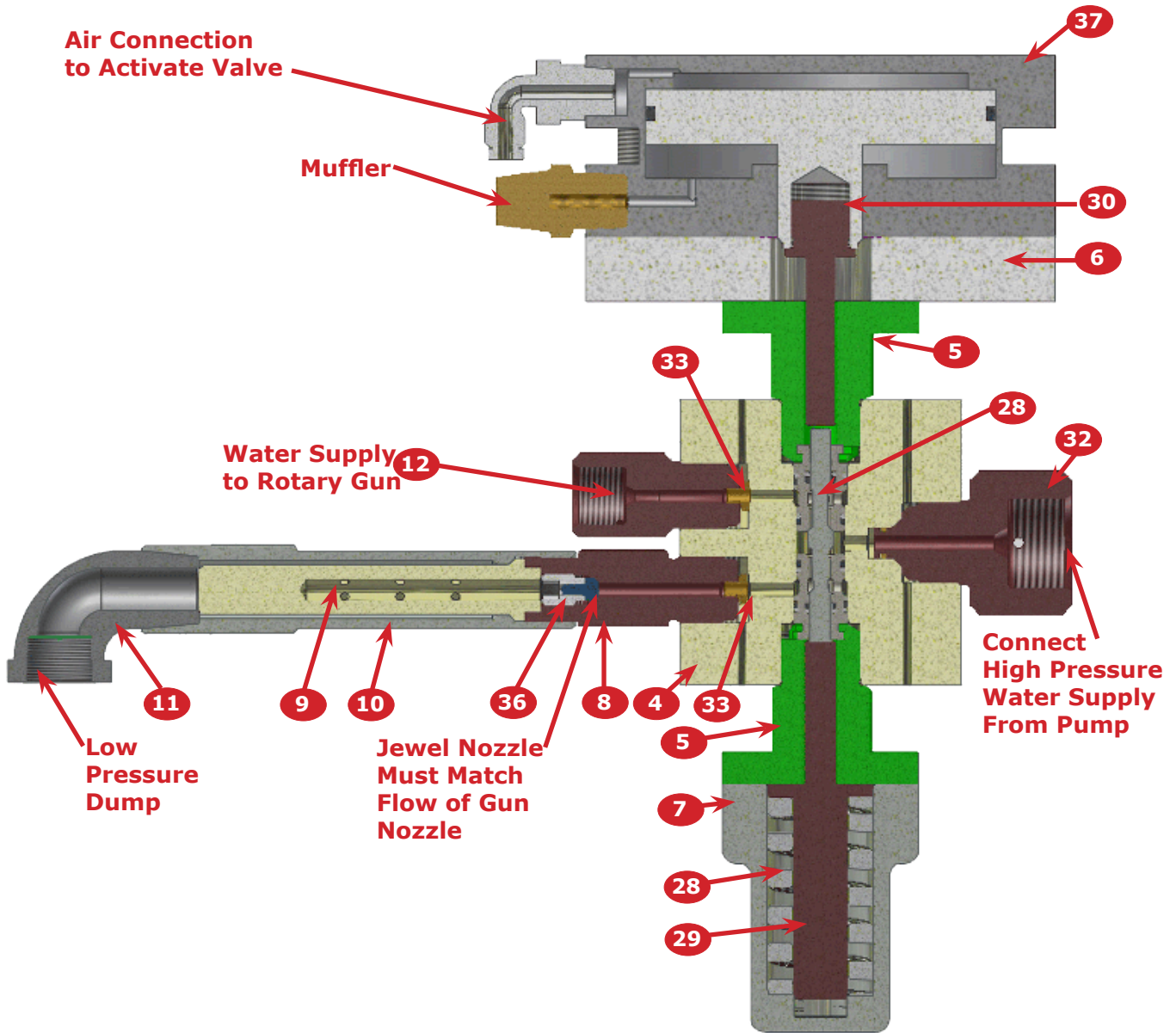

**Tri-Mode Cartridge  
Part # 60-070-111**

## Figure 3 - Parts List for the APS TRI-MODE VALVE

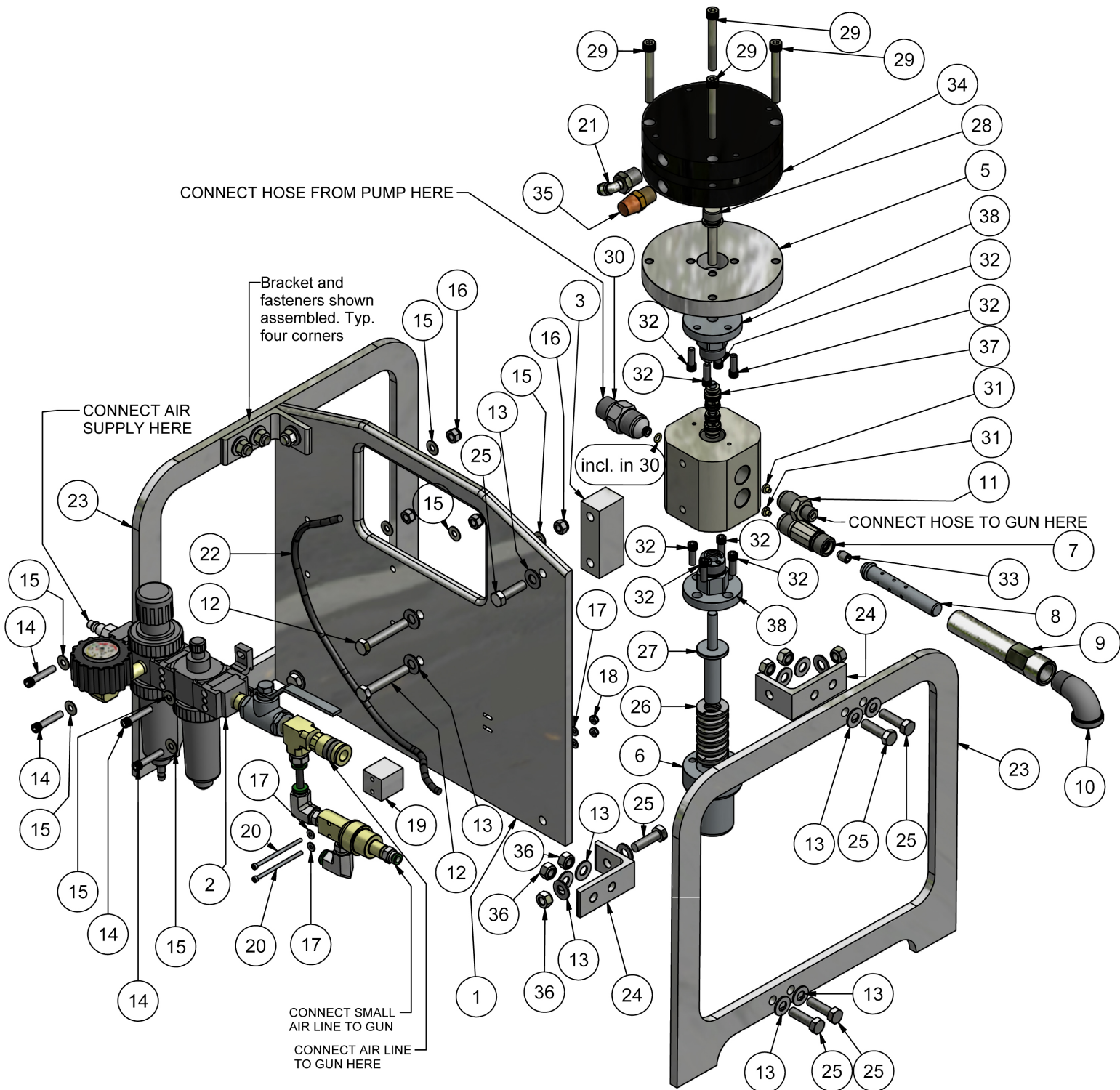

## Section 2

### Parts List for the APS TRI-MODE VALVE

ITEM	QTY	PART #	DESCRIPTION
1	1	60-070-006	MAIN FRAME PLATE
2	1	60-070-034	AIR SIDE SUB ASSEMBLY
3	1	60-070-013	SPACER BLOCK
4	1	60-070-001	VALVE BLOCK
5	1	60-070-020	ACTUATOR MOUNTING PLATE
6	1	60-070-007	SPRING HOLDER
7	1	60-070-039	ADAPTER FOR JEWEL NOZZLE HOLDER
8	1	60-070-040	ENERGY DISSIPATER TUBE
9	1	60-070-041	ENERGY DISSIPATER OUTER TUBE
10	1	60-070-042	1/2"NPT ELBOW
11	1	60-070-043	9/16" H.P. HOSE ADAPTER
12	2	10-016-225	VALVE BLOCK MOUNTING BOLT - 3/8"-16 x 2-1/4" LONG
13	2	10-010-001	SS WASHER - 3/8" PLAIN
14	4	10-001-125	1/4"-20 SHCS x 1-1/4" LONG
15	8	10-010-003	S WASHER - 1/4" PLAIN
16	4	10-100-001	1/4"-20 NYLON LOCKNUT
17	4	10-010-004	S WASHER - #6 PLAIN
18	2	10-100-004	6-32 NYLON LOCKNUT
19	1	60-070-044	VERSA VALVE MOUNTING BLOCK
20	2	10-009-250	#6-32 SS SHCS x 2-1/2" LONG
21	1	60-070-045	MALE ELBOW SWIVEL 1/4" TUBE x 3/8" NPT (Parker Part No. W169PL-4-6)
22	1	60-072-040	1/4" TUBING
23	2	60-070-005	END FRAME
24	4	60-070-010	BRACKET
25	1	10-016-125	3/8"-16 SS BOLT
26	1	60-070-009	SPRING
27	1	60-070-008	SPRING PLUNGER
28	1	60-070-019	ACTUATOR ROD
29	4	10-002-250	5/16"-18 SS SHCS x 2-1/2" LONG
30	1	60-070-052	ADAPTER, 7/8"-14 TYPE M x 1"-12 J/S with URETHANE O-RING 2-010
31	2	17-000-000	BRASS BUTTON SEAL
32	8	10-001-075	1/4"-20 SS SHCS 3/4" long
33	1	17-003-001	NOZZLE HOLDER (Jewel)
34	1	60-070-038	PARKER AIR CYLINDER
35	1	60-070-055	Muffler - 3/8" NPT M
36	1	10-100-002	3/8"-16 Nylon Lock Nut
37	1	60-070-111	Tumble Box Cartridge Assemblt
38	2	60-070-104	Cartridge Adapter



### Regular Maintenance of the APS Tri-Mode Tumblebox

Regular maintenance of the APS TRI-MODE VALVE must include keeping it as clean as possible. Any residue from blasting operations should be washed off with clean water, and the tumblebox wiped down with a dry rag, prior to placing in storage. The air motor trigger should be lubricated with light grade machine oil.

#### Replacement of Cartridge

The replacement of the Cartridge (Part #28) is necessary if there is a significant pressure loss or if there is water leaking out of the energy dissipator tube while the gun is in the "pressurized dump mode". This is the procedure for removing and replacing the cartridge.

**Step 1:** Disconnect the air signal hose (Fig 4) from the Air Actuator QD (Part #22).



Fig 4

**Step 3:** Having loosened the actuator and cartridge adapter from the valve block, turn the actuator by hand until the assembly can be removed (Fig 6).



Fig 6

**Step 4:** Tilt the Tri-Mode Valve (Fig 7), unscrew the spring holder/cartridge adapter assembly using a crescent wrench, and withdraw the lower part of the cartridge.

**Step 2:** Using a crescent wrench, loosen the cartridge adapter from the valve block (Fig 5). This will also withdraw the upper part of the cartridge.

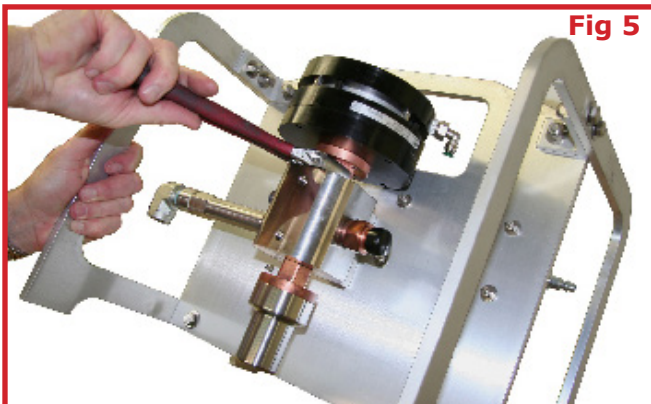

Fig 5

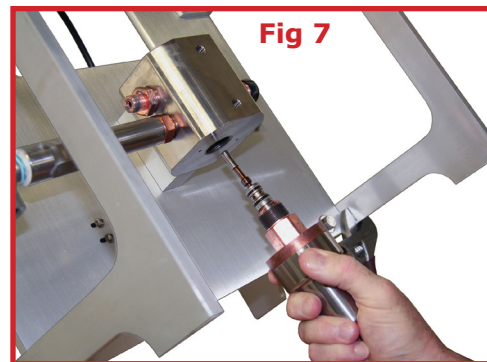

Fig 7

**Step 5:** Inspect the valve block for any debris or damage. Wipe the block and spring holder/cartridge adapter with a clean rag. Install a new cartridge and reassemble using Anti-Sieze Lubricant on all threaded connections.

## Replacement of Energy Dissipater

The replacement of the Energy Dissipater (Part #10) is necessary when water begins leaking from the dump side of the Tri-Mode Valve while blasting, thereby causing a loss of flow through the control gun. The energy dissipator tube assembly typically receives the heaviest wear during water jetting operation. This is the procedure for removing and replacing the energy dissipator.

**Step 1:** Use a crescent wrench to loosen, then unscrew the energy dissipator outer tube (Part #10) from the valve block (Part #4). (Fig 8)



**Step 3:** Reconnect all air and water hoses at the correct points. Use Teflon Tape and Loctite Thread Sealant on hose connections to guard against leaking and pressure loss. (Fig 10).

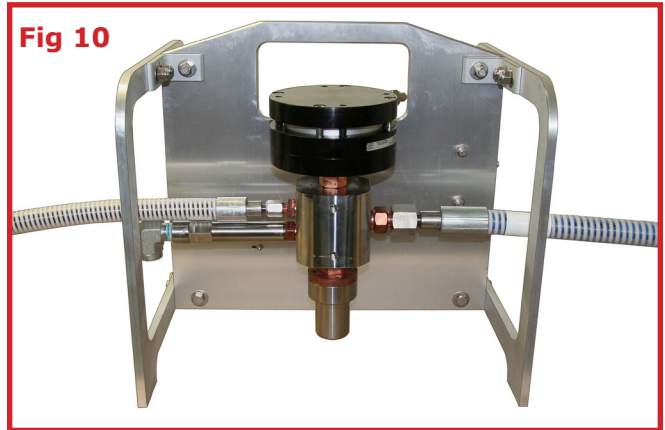

**Step 2:** Remove the energy dissipater from the outer tube and replace with new one. Reassemble making sure that all threaded connections receive Anti-Sieze Lubricant and all NPT threads receive Teflon tape. (Fig 9).

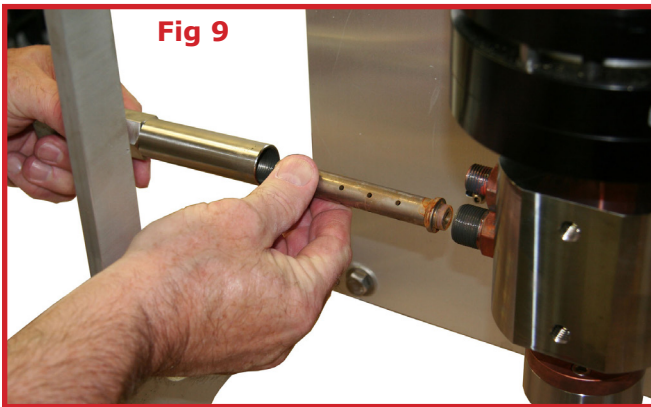

## Section 4

### Operating Specifications

- 1) Maximum supply pressure of water to the gun = 40,000 PSI
  - 2) Maximum flow of water = 7 GPM
  - 3) Maximum operating speed of rotation = 4,000 RPM  
(3,000 – 3,500 RPM Recommended)
  - 4) Maximum air pressure supply to gun = 100 PSI
- 

## Section 5

### Necessary Additional Equipment

The APS TRI-MODE VALVE is specifically designed to work with air powered rotary barrel guns such as the APS COBRA. The Tri-Mode Valve will control the flow of high pressure water to the gun as well as control and condition the air that the COBRA will need to power its air motor. Rotary barrel guns manufactured by other OEMS will also work well with this valve.

#### Cobra Rotary Gun

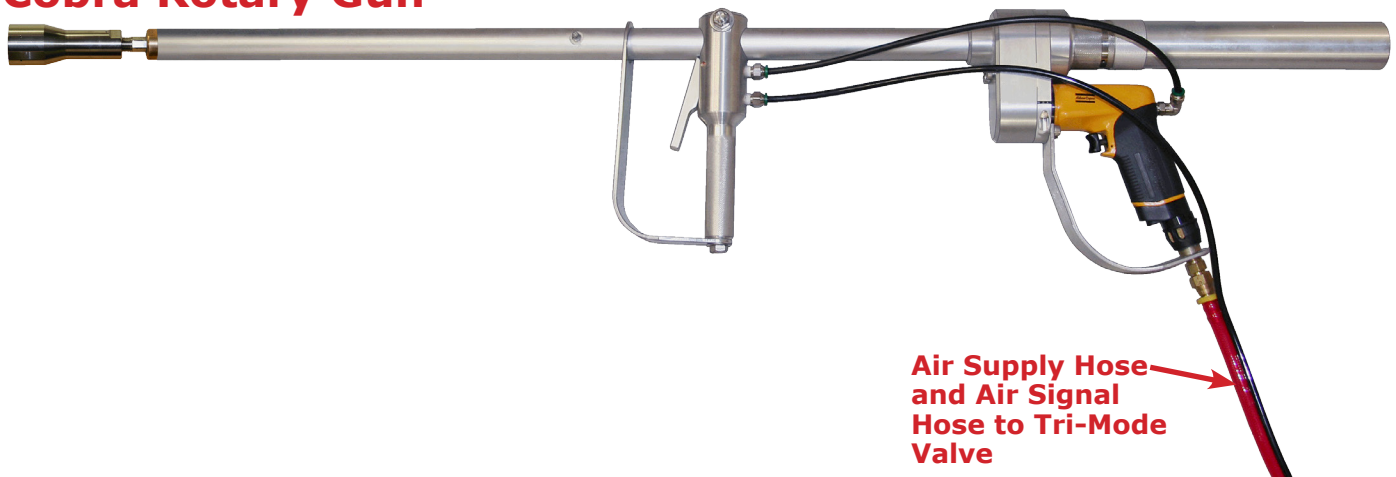

## Section 6

### **How to Hook Up the APS Tri-Mode Valve (into a system with Pump & Cobra Rotary Control Gun)**

There are three major elements, which comprise a system.

They are:

Element #1 - a pump, usually with an onboard air compressor,

Element #2 - a “tumble box” (e.g. TRI-MODE VALVE) and

Element #3 - an APS COBRA rotary style gun.

The pump (Element #1 in the system) can be any of the 40,000 PSI units available on the market. Flow and nozzles must be chosen so as not to exceed the maximum flow of 7 GPM through the gun. A supply hose will carry the high pressure flow to the tumble box, where it will connect to the flow control valve.

The tumble box (Element #2 in the system) controls the high pressure flow from the pump to the gun. It also controls the compressed air flow to operate the gun and it uses air to operate the flow control valve to permit the high pressure flow to the gun (see O & M Manual for TRI-MODE Valve). The APS COBRA rotary style gun (Element 3) in the system is where the work is done.

---

## Section 7

### **To connect the system components proceed as follows:**

- Connect high pressure supply hose from pump (1) to Tri-Mode Flow Control Valve (2).
  - Connect compressor (3) to air side of Tri-Mode (4).
  - Connect high pressure hose from Tri-Mode Flow Control Valve (5) to back of APS COBRA rotary gun (6).
  - Connect the air Supply/signal hose from Tri-Mode air side (7) to the inlet to the air pistol inlet (8) and the smaller signal hose to the front handle of the APS COBRA (9).
  - The system is now ready to start.
  - **Start the pump and bring it up to pressure.** (It is assumed for the purposes of this O & M Manual that the Tri-Mode Valve will be operating in the pressure dump mode. For other methods of setting up the Tri-Mode Valve see the separate O & M Manual for that product). Check to see that water is dumping from the dump port (11) of the Tri-Mode Valve.
  - Open the air valve (10), **WARNING: THE GUN IS READY TO OPERATE.**
  - Make sure that the gun is pointed in a safe direction, and then squeeze both the trigger on the air pistol and on the front handle at the same time. The gun will commence to operate. It is now ready for use.
- (Note:** The main air supply hose and the signal hose are joined together along their length to form a single unit).
- Before starting the compressor make sure that the main valve (10) on the air side the Tri-Mode Valve is closed.



**Pump with Compressor**

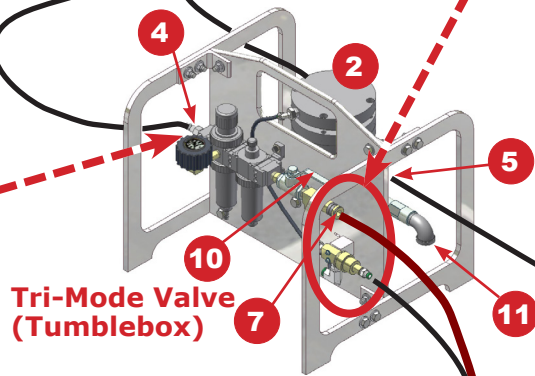
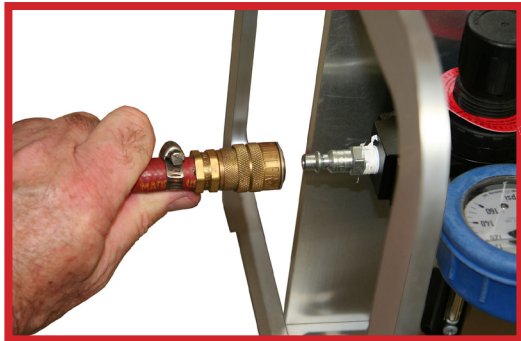

**Tri-Mode Valve  
(Tumblebox)**

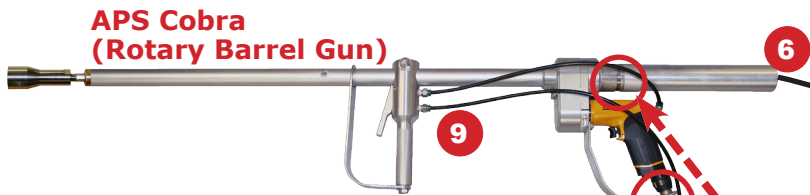

**APS Cobra  
(Rotary Barrel Gun)**



## Section 8

### Safety Considerations

- 1) Follow all safety recommendations when using this or any related equipment.
- 2) DO NOT EXCEED THE STATED OPERATING PRESSURE for this equipment.
- 3) Allow only personnel who are fully trained to operate this or any associated equipment.
- 4) Before operating this or any associated equipment, carry out an inspection to ensure that it is in good condition, and does not show any signs of abuse. Check for missing or damaged components, including trigger guards, hose shrouds and damaged or worn hoses. If any problems are found or suspected, make sure they are checked and corrected before using the equipment.
- 5) DO NOT TIE, TAPE OR IN ANY WAY SECURE TRIGGERS IN THE ACTIVATED POSITION.
- 6) DO NOT ATTEMPT TO DEFEAT ANY SAFETY DEVICES ON THIS OR ANY HIGH PRESSURE EQUIPMENT.

---

## Section 9

### Risks associated with the use of the Tri-Mode Valve (Tumble Box)

The most significant risks associated with the use of the **Tri-Mode Valve** are from **worn or damaged hoses**. All hoses and hose connections must be thoroughly inspected prior to commencing work with this equipment, and any that show signs of damage or deterioration must be replaced.

The choice of orifice size for use in the **Energy Dissipater** of the **Tri-Mode Valve**, requires careful attention. It is essential that the flow rating for this orifice is the same as the combined flow for all of the jets used in the nozzle connected to the **APS Cobra** (or similar) rotary gun. Selecting an orifice that is too small will over-pressure the pump and supply hoses. An orifice that is too large will cause the pump to operate below the optimum pressure, which will affect the efficiency any other gun which

is operating on the same system.

In the event of an emergency there is shut-off valve on the air side of the **Tri-Mode Valve**, which will stop the flow of air to the gun, which in turn will shut down the flow of high pressure water to the gun.

The greatest risks to be considered when using this equipment are associated with the rotary gun. For that reason the part of the **O & M Manual for the APS Cobra Rotary Gun** dealing with safety risks is reproduced below:

### **Risks associated with the use of APS Cobra Rotary Gun (or similar)**

It is recommended that this equipment is used with a front barrel that is 48" long, when measured from the gear case at the front of the air motor to the end of the rotating barrel. This will prevent the operator from being able to direct high pressure jets onto his feet. (*see also Recommended Safety Equipment*) In some special applications, such as confined spaces or where there is difficult access, shorter barrels are used, and depending on the specific circumstances, special care should be exercised to prevent the risk of an operator hitting any part of his own body. Special care could include protective clothing, or a specially designed shield.

The other most likely cause of operator injury associated with this gun is from a supply hose failure. This is a concern common to all water blasting guns regardless of the operating pressure or type. The **APS COBRA** has an aluminum shroud extending from the back of the swivel assembly, which covers the connection of the hose to the gun, which is the most common point of failure. It is essential to include the supply hose in the pre-operating check of the gun and any associated equipment. Most 40,000 PSI supply hoses can be provided with an abrasion shield, which helps minimize damage to the hose. Burst shields can also be installed, but they are very heavy and so more difficult to use.



**ADVANCED PRESSURE SYSTEMS**

701 S. Persimmon St., Suite 85 - Tomball, TX 77375

Toll Free in North America: (877) 290-4277

Phone: (281) 290-9950 Fax: (281) 290-9952

E-mail orders: [sales-team@waterblast.pro](mailto:sales-team@waterblast.pro)

**[WWW.ADVANCEDPRESSURESYSTEMS.COM](http://WWW.ADVANCEDPRESSURESYSTEMS.COM)**

**[WWW.WATERBLAST.PRO](http://WWW.WATERBLAST.PRO)**