

| Rev No | Revision note | Date | Initials | Checked |
|--------|---------------|------------|----------|---------|
| 01 | First Issue | 03.07.2017 | SF | SF |
| XX | XX | XX-XX-XXXX | XX | XX |

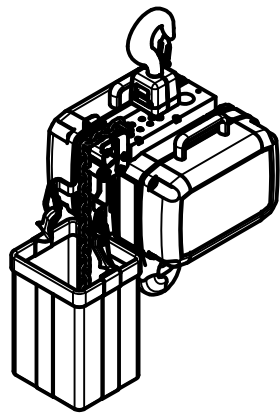
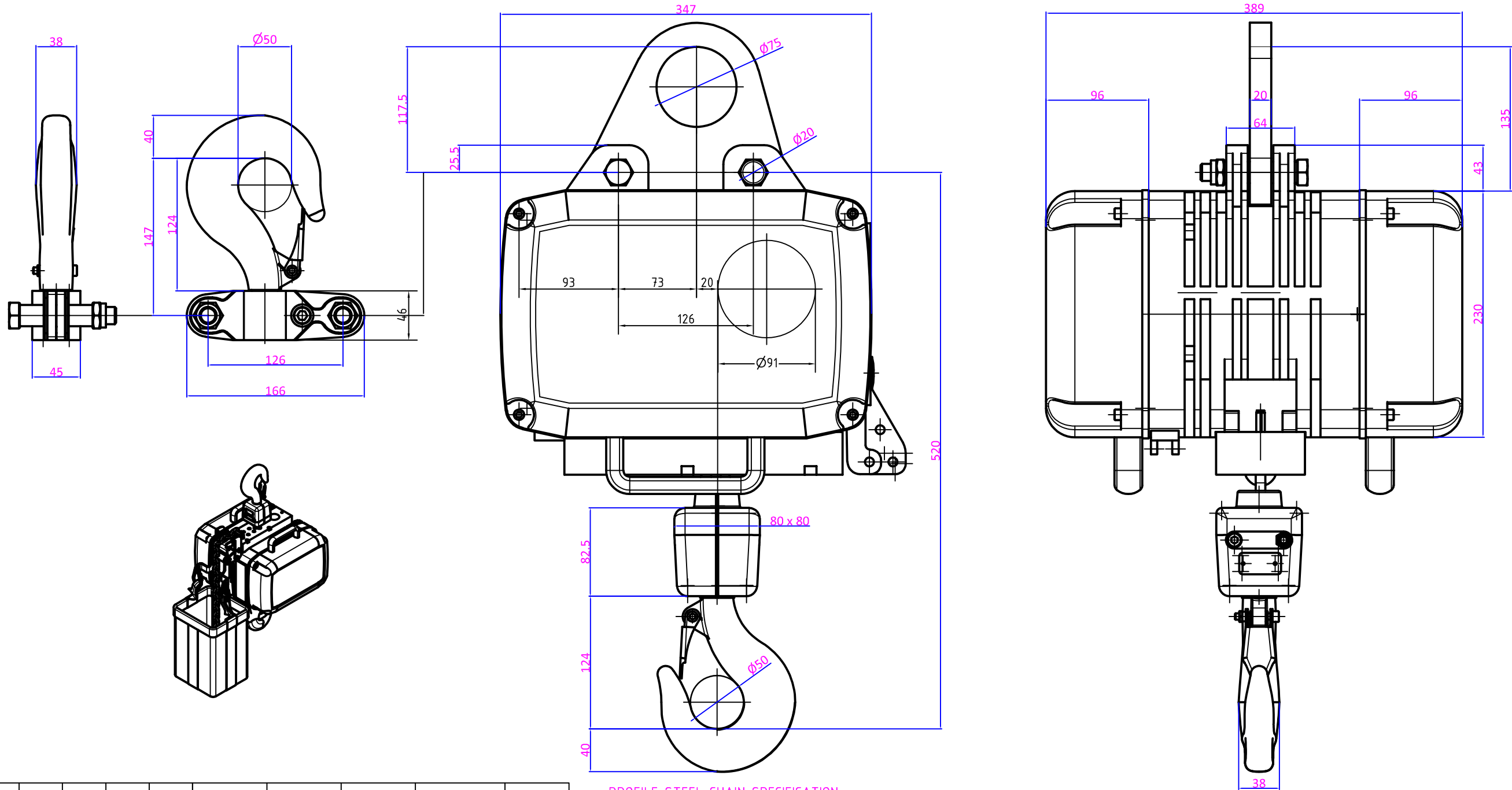

PROFILE STEEL CHAIN SPECIFICATION

- Steel Chain Finish: Black Phosphated
- Chain Grade: DAT (8SS), FEM9.671
- Chain Size: 10mm x 28mm
- Chain Weight Per metre: 1.75kg

CHAIN HOIST ADDITIONAL SPECIFICATIONS

- Protection DIN 40050: IP55
- Insulation class: F
- Fuse protection generally: 10A
- Load hook DIN 15401: 1

| Classification | M3/1Bm | M4/1Am | M5/2m | M5/2m | Lifting speed | Motor power | 3Ph 3x400V 50Hz | Weight unequipped | Chain safety static |
|----------------|--------|--------|-------|-------|---------------|-------------|-----------------------|----------------------|---------------------------|
| | kg | kg | kg | kg | | | | | |
| Switches /h | 150 | 180 | 240 | 300 | | | | | |
| Duty factor % | 25% | 30% | 40% | 50% | | | | | |
| | kg | kg | kg | kg | m/min. 50Hz | kW (50 Hz) | A | kg | |
| LG250/1N D8 | 2500 | 2000 | 1600 | 1250 | 6.4 | 3.06 | 7.3 | 53 | 6.4 : 1 |
| LG250/1NL D8 | 2500 | 2000 | 1600 | 1250 | 3.2 | 1.53 | 4.8 | 53 | 6.4 : 1 |
| LG250/1SL D8 | 1600 | 1250 | 1000 | 800 | 5 | 1.5 | 4.8 | 53 | 10.25 : 1 |
| LG250/1NF D8 | 2500 | 2000 | 1600 | 1250 | 6.4/1.6 | 3.06/0.77 | 8.5/6.6 | 55 | 6.4 : 1 |

| | | | |
|---------|------------|---|--|
| SCALE: | 1:4 |  LIFT TURN MOVE LTD www.liftturnmove.co.uk <small>INDUSTRIAL & ENTERTAINMENT LIFTING EQUIPMENT</small> | Unit 2 Stadium Court, Plantation Road, Bromborough, United Kingdom, CH62 3QG Tel: +44 151 6490467 Email: Sales@liftturnmove.co.uk |
| SIZE: | A3 | | |
| SHEET: | 1 OF 1 | | |
| DRAWN: | GIS | | |
| CHECK: | SF | TITLE: | LG250 D8 Single Fall Arrangement |
| ISSUED: | 03.07.2017 | DWG NO: | LG250-D8-1F |
| REV: | 01 | | |