

Rev No	Revision note	Date	Initials	Checked
01	First Issue	03.07.2017	SF	SF
XX	XX	XX-XX-XXXX	XX	XX

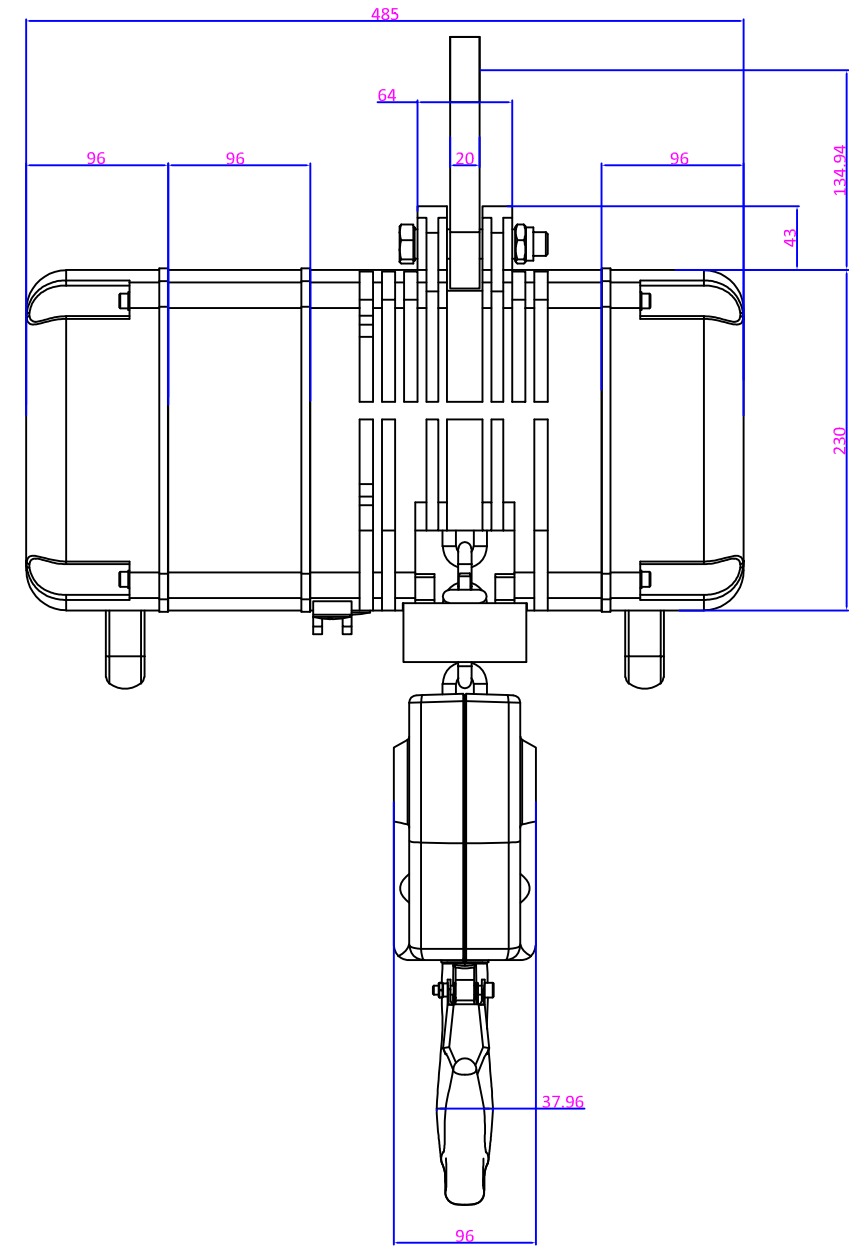
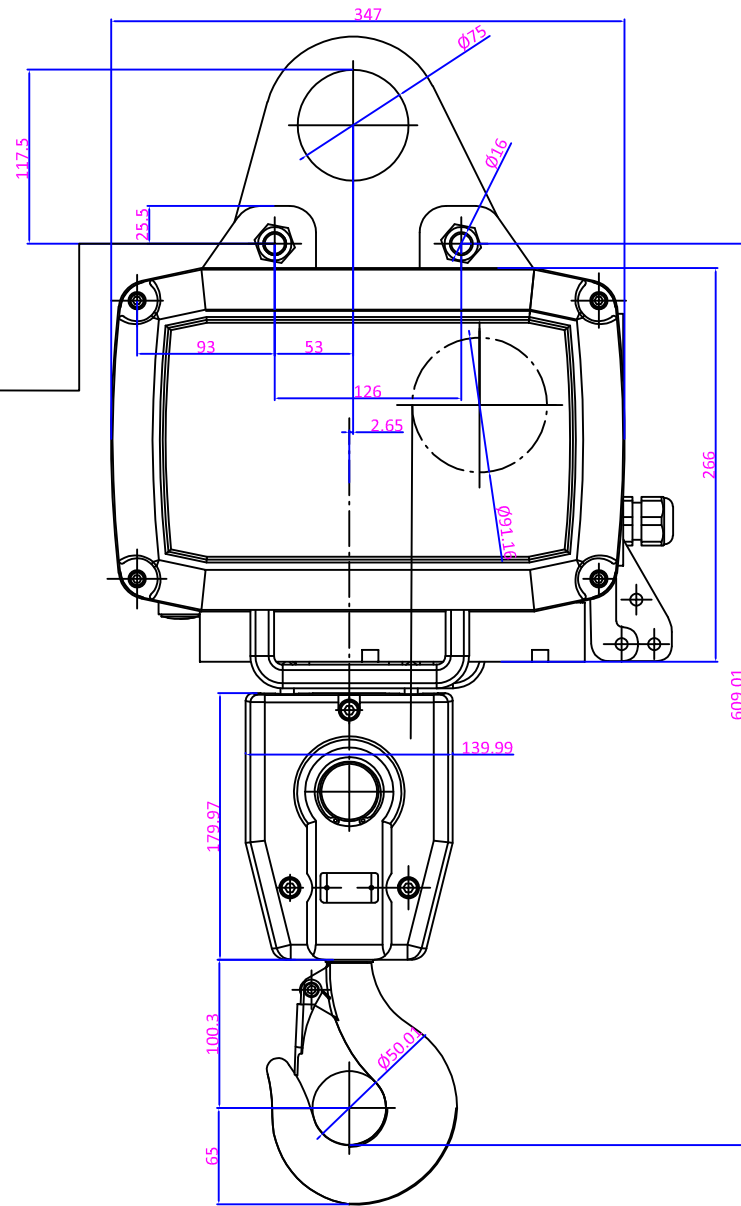
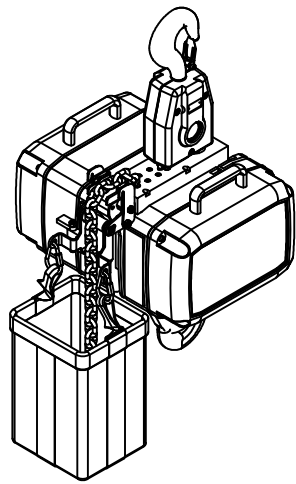
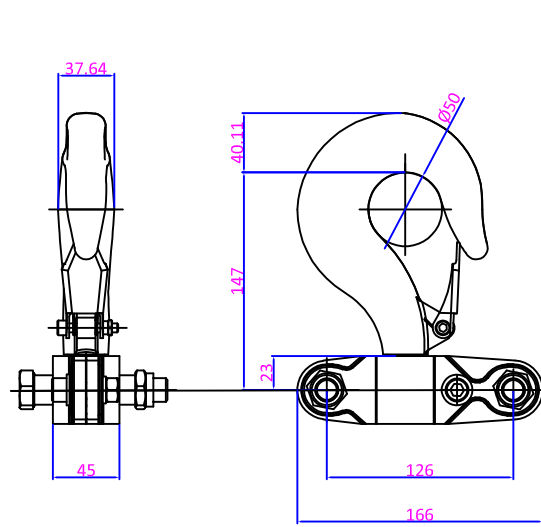

Classification	M3/1Bm	M4/1Am	M5/2m	M5/2m	Lifting speed	Motor power	3Ph 3x400V 50Hz	Weight unequipped	Chain safety static
	kg	kg	kg	kg					
Switches /h	150	180	240	300					
Duty factor %	25%	30%	40%	50%					
	kg	kg	kg	kg	m/min. 50Hz	kW (50 Hz)	A	kg	
LG250/2N D8	5000	4000	3200	2500	3.2	3.06	7.3	53	6.4 : 1
LG250/2NL D8	5000	4000	3200	2500	1.6	1.53	4.8	53	6.4 : 1
LG250/2SL D8	3200	2500	2000	1600	2.5	1.5	4.8	53	10.25 : 1
LG250/2NF D8	5000	4000	3200	2500	3.2/0.8	3.06/0.77	8.5/6.6	55	6.4 : 1

**PROFILE STEEL CHAIN SPECIFICATION**

- Steel Chain Finish: Black Phosphated
- Chain Grade: DAT (8SS), FEM9.671
- Chain Size: 10mm x 28mm
- Chain Weight Per metre: 1.75kg

**CHAIN HOIST ADDITIONAL SPECIFICATIONS**

- Protection DIN 40050: IP55
- Insulation class: F
- Fuse protection generally: 10A
- Load hook DIN 15401: 1

SCALE:	1:5	 <b>LIFT   TURN   MOVE   LTD</b> <a href="http://www.liftturnmove.co.uk">www.liftturnmove.co.uk</a> <small>INDUSTRIAL &amp; ENTERTAINMENT LIFTING EQUIPMENT</small>	Unit 2 Stadium Court, Plantation Road, Bromborough, United Kingdom, CH62 3QG Tel: +44 151 6490467 Email: Sales@liftturnmove.co.uk
SIZE:	A3		
SHEET:	1 OF 1		
DRAWN:	GIS		
CHECK:	SF	TITLE:	LG250 D8 Double Fall Arrangement Double Brake
ISSUED:	03.07.2017	DWG NO:	LG250-D8-2F-DB
REV:	01		