



Customization Installation Instructions

January 14, 2011

Tacoma Bed Extender

Models:

Tacoma 2005 -

CIIT1052

TOYOTA TACOMA 2005 - BED EXTENDER Preparation

Part Number: PT392-35000

Kit Contents

Item #	Quantity Req'd.	Description
1	1	Curved Tube Assembly - Right
2	1	Curved Tube Assembly - Left
3	3	Center Tube
4	1	Hardware Bag
5	1	Installation Instructions
6	1	Care Card

Hardware Bag Contents

Item #	Quantity Req'd.	Description
1	1	Bracket - Left
2	1	Bracket - Right
3	6	M5x14 Button Head Bolt
4	6	M5 Hex Flange Nut
5	6	Double Wedge-Threaded
6	6	Double Wedge-Thru Hole
7	6	PT Screw
8	1	Drill Template - Driver side
9	1	Drill Template - Passenger side

Additional Items Required For Installation

Item #	Quantity Req'd.	Description

Conflicts

Recommended Tools

Personal & Vehicle Protection	Notes
Safety Glasses	
Special Tools	Notes
None	
Installation Tools	Notes
Center Punch	
Drill	6.0 mm Drill Bit
Drill Stop	6.0 mm
Torque Wrench	
Socket	8mm, 10 mm
Torx Bit	T-20
Allen Key	3 mm
Deburring Tool	
Rubber Mallet	Small
Special Chemicals	Notes
Sealant	3M Ultrapro Autobody, P/N: 08302

NOTE: Part number of this accessory may not be the same as the part number shown.

General Applicability

All 2005 Tacoma and newer

Recommended Sequence of Application

Item #	Accessory
1	

*Mandatory

Vehicle Service Parts (may be required for reassembly)

Item #	Quantity Req'd.	Description
1		
2		
3		

Legend

	STOP: Damage to the vehicle may occur. Do not proceed until process has been complied with.
	OPERATOR SAFETY: Use caution to avoid risk of injury.
	CAUTION: A process that must be carefully observed in order to reduce the risk of damage to the accessory/vehicle and to ensure a quality installation.
	TOOLS & EQUIPMENT: Used in Figures calls out the specific tools and equipment recommended for this process.
	REVISION MARK: This mark highlights a change in installation with respect to previous issue.
	SAFETY TORQUE: This mark indicates that torque is related to safety.

TOYOTA TACOMA 2005 - BED EXTENDER

Procedure

Care must be taken when installing this accessory to ensure damage does not occur to the vehicle. The installation of this accessory should follow approved guidelines to ensure a quality installation.

These guidelines can be found in the "Accessory Installation Practices" document.

This document covers such items as:-

- Vehicle Protection (use of covers and blankets, cleaning chemicals, etc.).
- Safety (eye protection, rechecking torque procedure, etc.).
- Vehicle Disassembly/Reassembly (panel removal, part storage, etc.).
- Electrical Component Disassembly/Reassembly (battery disconnection, connector removal, etc.).

Please see your Toyota dealer for a copy of this document.

1. Install Mounting Brackets.

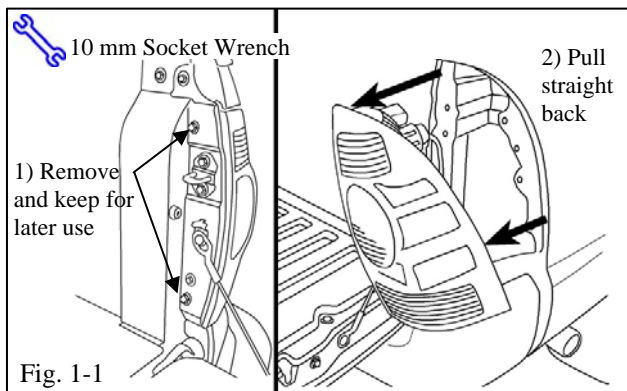

Fig. 1-1

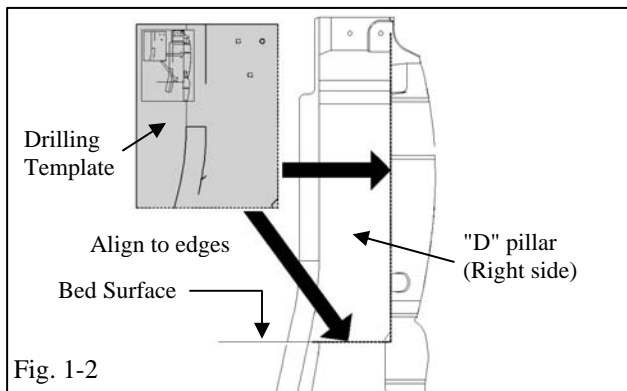

Fig. 1-2

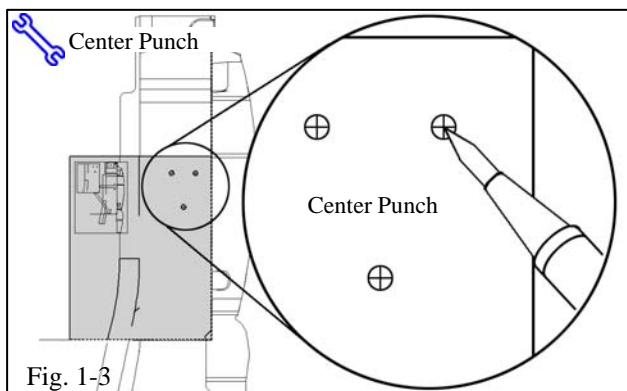

Fig. 1-3

STOP (a) Follow the Installation Procedures and be careful not to scratch the vehicle.

+ (b) During installation, always wear safety glasses.

(c) Bracket installation.

! (1) Carefully remove the lamp assemblies (Fig. 1-1).

(2) Remove the "D" pillar drilling templates from the hardware bag. Fold or cut on the dashed lines as described on the template.

! (3) Align the right side template to the right side "D" pillars as described on the template (Fig. 1-2).

! (4) Using the center punch, carefully mark the center of the three mounting holes thru the template onto the sheet metal (Fig. 1-3).

TOYOTA

Procedure

TACOMA

2005 -

BED EXTENDER

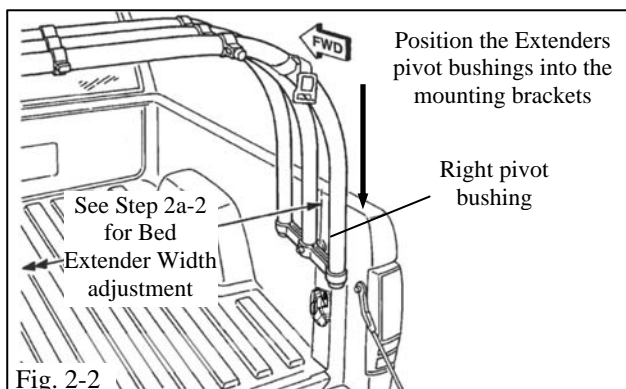
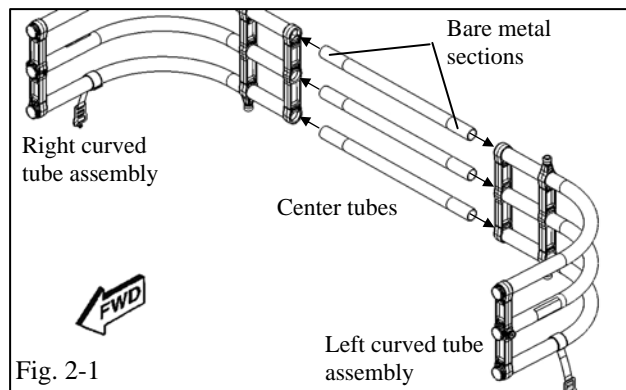
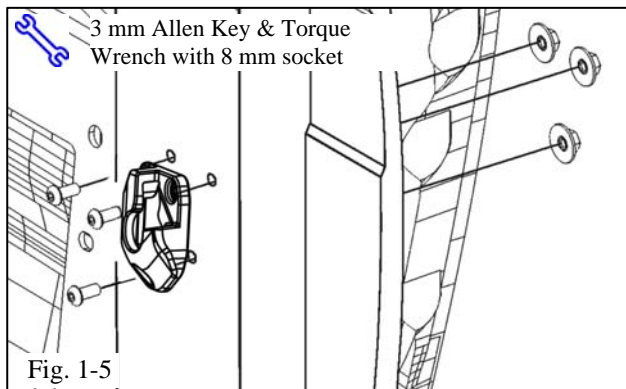
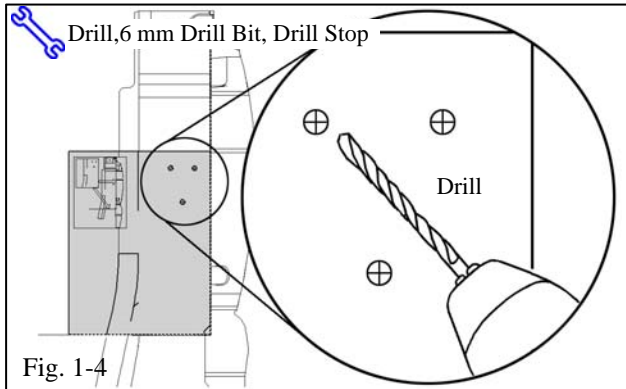

(5) Drill the three holes thru the center point just marked with a 6.0 mm (or 15/64") drill bit (Fig. 1-4). Set drill stop to 1".



(6) Deburr the holes just drilled and apply sealant around the holes.

(7) Repeat Steps 1. (c) (3) to 1. (c) (6) for the left hand side, using the left side template.



(8) Clean off metal debris from drilling, and bolt the brackets on to the "D" pillar as shown in Fig. 1-5. Tighten the three nuts



NOTE: Be careful not to scratch the vehicle.

(9) Re-install the lamp assemblies and firmly tighten the bolts. Tighten to 5.4 N-m (45 lbf-in).

2. Assemble and Install Bed Extender.

(a) Extender installation.

(1) Insert the center tubes into the right curved tube section until no bare metal on the center tubes are exposed. Then insert the left curved tube section onto the center tubes until the rest of the bare metal sections are covered (Fig. 2-1).



NOTE: Do not allow bare metal to be exposed

(2) Adjust the Bed Extender assembly width by sliding the right/left tube sections in or out on the center tubes so that the assembly can be installed into the mounting brackets as shown in Fig 2-2.

(b) Positioning of Center Tube Stanchions.

(1) Rotate the assembly onto the open tailgate.

NOTE: It is normal for the Bed Extender to have some resistance when first rotated in the bracket.

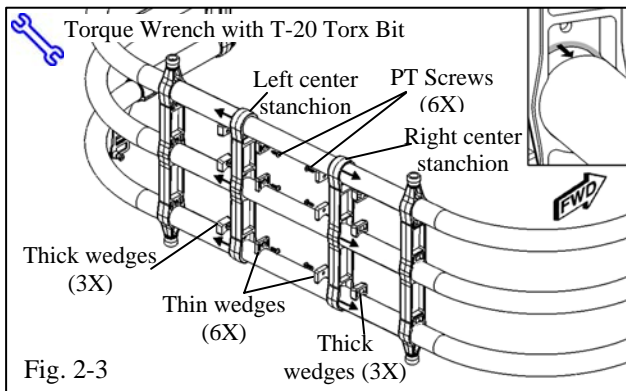

Fig. 2-3

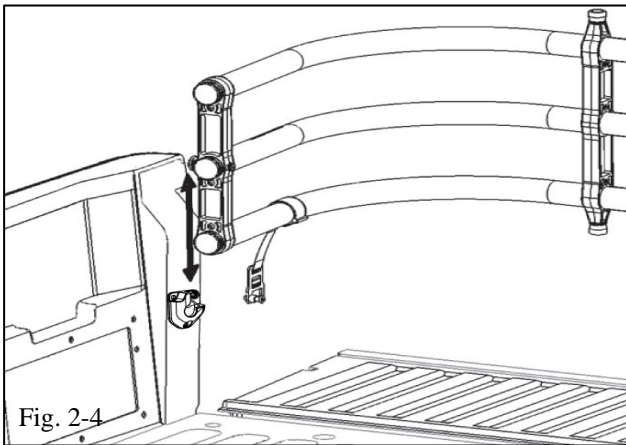

Fig. 2-4

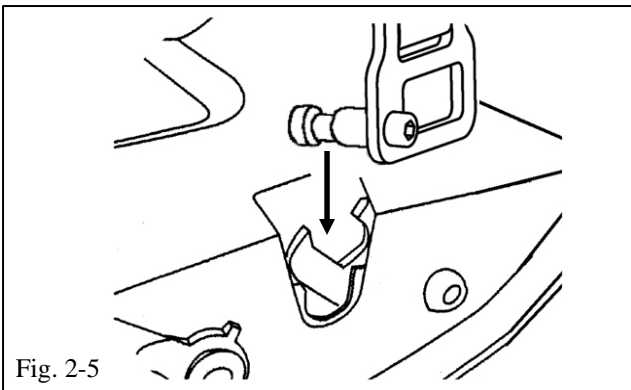

Fig. 2-5

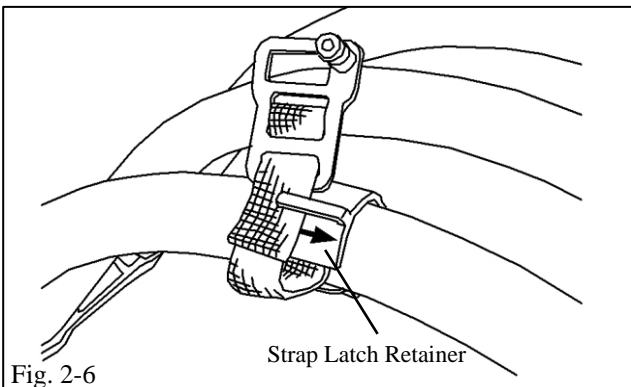

Fig. 2-6

Strap Latch Retainer

- !** (2) Move the right center stanchion over the right tube section by tapping with a rubber mallet (Fig 2-3).

NOTE: Tapping with excessive force may damage extender and/or vehicle. Be careful not to scratch the center tubes.

- (3) Insert wedges into the three (3) wedge pockets of stanchion on both sides of each stanchion with the thinner wedges facing the center of the Bed Extender (Fig 2-3).

- !** (4) Insert three (3) PT screws from the center of the Bed Extender. With the T-20 Torx bit on the torque wrench, tighten the three (3) screws after stanchion is securely in place to 2.3 N-m (20 lbf-in). (Fig 2-3)

- (5) Repeat Steps 2. (b) (2) through 2. (b) (4) for the other (left) center stanchion.

Operation of Angled Bracket

To remove, rotate Bed Extender 55° from tailgate and slide pivots out of mounting brackets. Make sure that the two straps are facing rearward.

To install, rotate Bed Extender 55° from tailgate and slide the pivots into mounting brackets as shown in Fig. 2-4.

- (c) Adjustment of Locking Straps.

- (1) Adjust strap length and position, in order to allow locking strap buckles to lock into tailgate (Fig 2-5).

- (2) When the Extender is in the inward position, clip the straps onto the Strap Latch Retainer as shown in Fig 2-6. This will prevent the buckles from rattling.

3. Care Card.



- !** (a) Place care card into glove box.

TOYOTA TACOMA 2005 - BED EXTENDER

Checklist - these points **MUST** be checked to ensure a quality installation.

Check:

Accessory Function Checks

- Bed extender adjustment.
- Tailgate strap adjustment.
-  Torque adjustment of stanchion screws.
-  Torque adjustment of bracket mounting bolts.

Look For:

Bed extender pivot point must rest in mounting brackets.

Tailgate straps must be able to lock into tailgate locks.

Stanchion screws must be tightened to 2.3 N-m (20 lbf-in).

Bracket mounting bolts must be tightened to 5 N-m (45 lbf-in).

Vehicle Function Checks

- Upright foot positioning on tailgate.
-  Re-mounting of the rear lamp assemblies.

Ensure that upright feet sit properly on tailgate edge

Ensure that the lamp assemblies are firmly secured and the lamps operate.

**2005 TOYOTA TACOMA BED EXTENDER
PASSENGER'S SIDE "D" PILLAR DRILLING TEMPLATE**

STEPS:

- 1) VERIFY THE TEMPLATE DIMENSIONS BEFORE DRILLING (example: measure the 1 ½ in. line to confirm accuracy. If incorrect, measure manually and use bracket as template)**
- 2) CUT OR FOLD TEMPLATE ON DASHED LINES**
- 3) USE CENTER PUNCH TO MARK HOLES**
- 4) PLACE THE ANGLE BRACKET ON TOP OF THE TEMPLATE TO INSURE THAT THE HOLES LINE UP**
- 5) USE A 6 mm DRILL BIT TO DRILL HOLES**

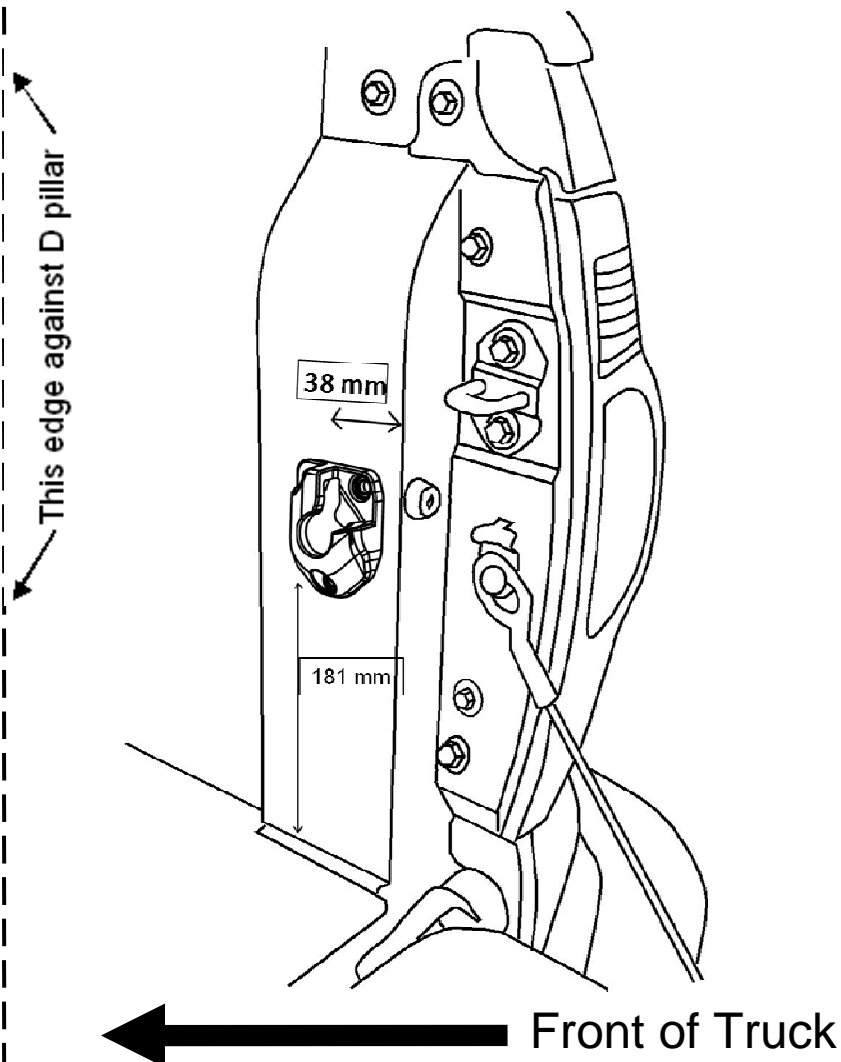
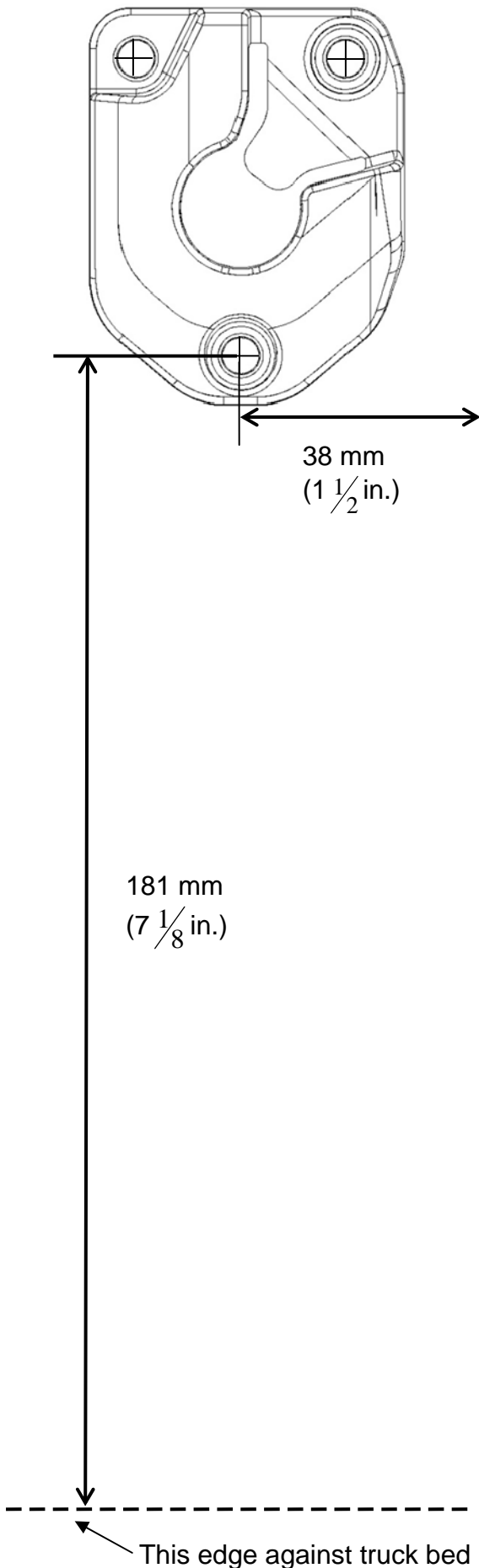

2005 TOYOTA TACOMA BED EXTENDER

DRIVERS SIDE "D" PILLAR DRILLING TEMPLATE

STEPS:

- 1) **VERIFY THE TEMPLATE DIMENSIONS BEFORE DRILLING** (example: measure the 1 ½ in. line to confirm accuracy. If incorrect, measure manually and use bracket as template)
- 2) CUT OR FOLD TEMPLATE ON DASHED LINES
- 3) USE CENTER PUNCH TO MARK HOLES
- 4) PLACE THE ANGLE BRACKET ON TOP OF THE TEMPLATE TO INSURE THAT THE HOLES LINE UP
- 5) USE A 6 mm DRILL BIT TO DRILL HOLES

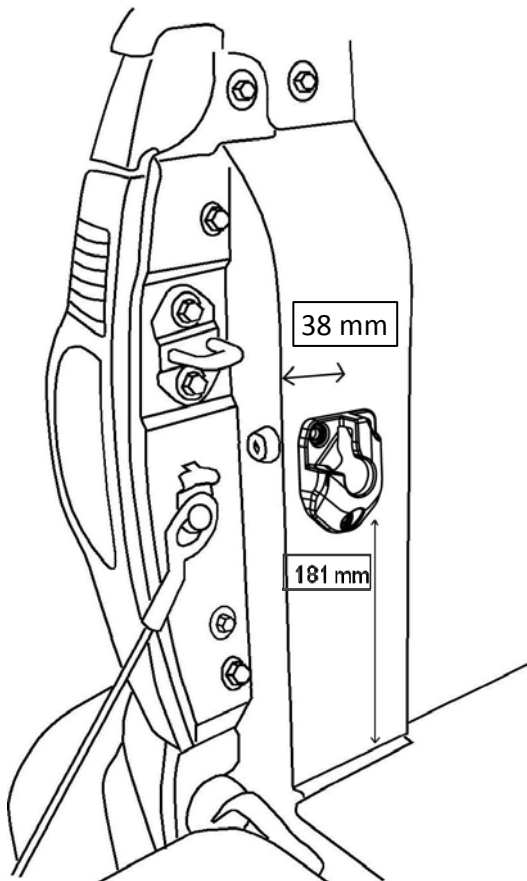

Angle Bracket mounted in truck

Front of Truck

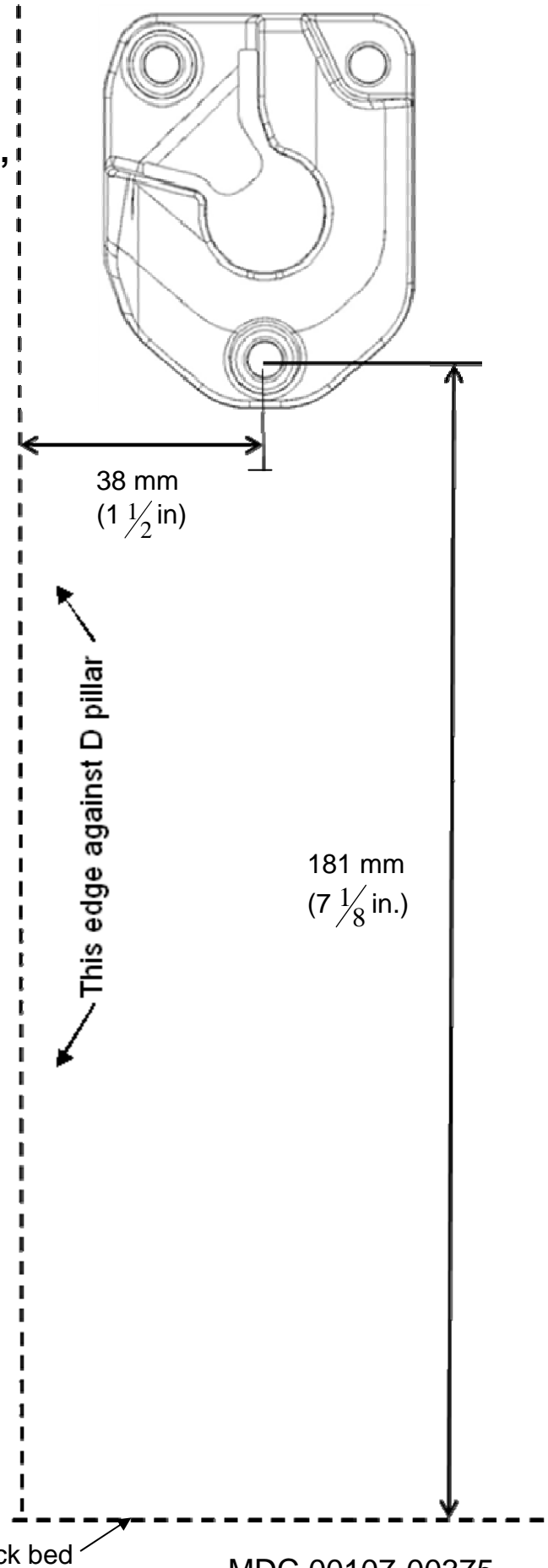

This edge against truck bed

MDC 00107-00375