

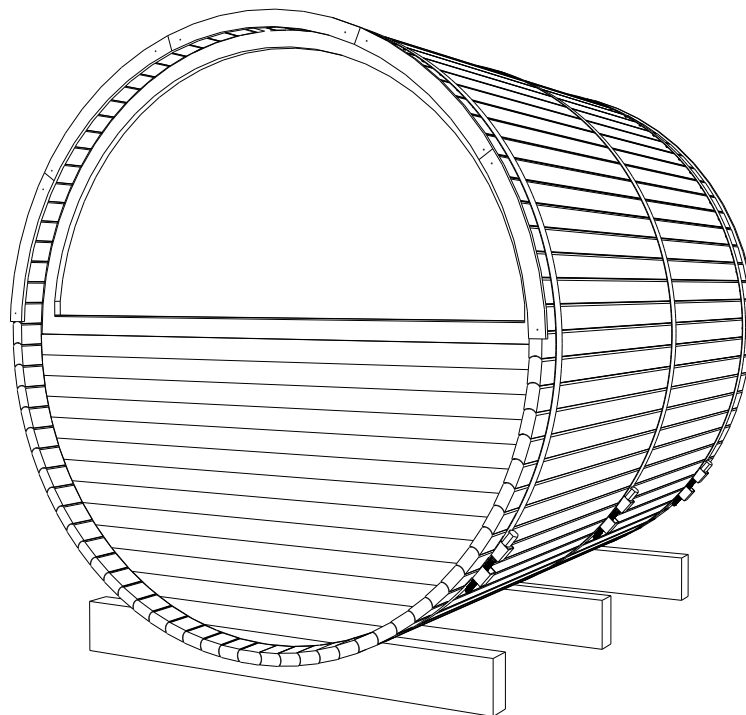

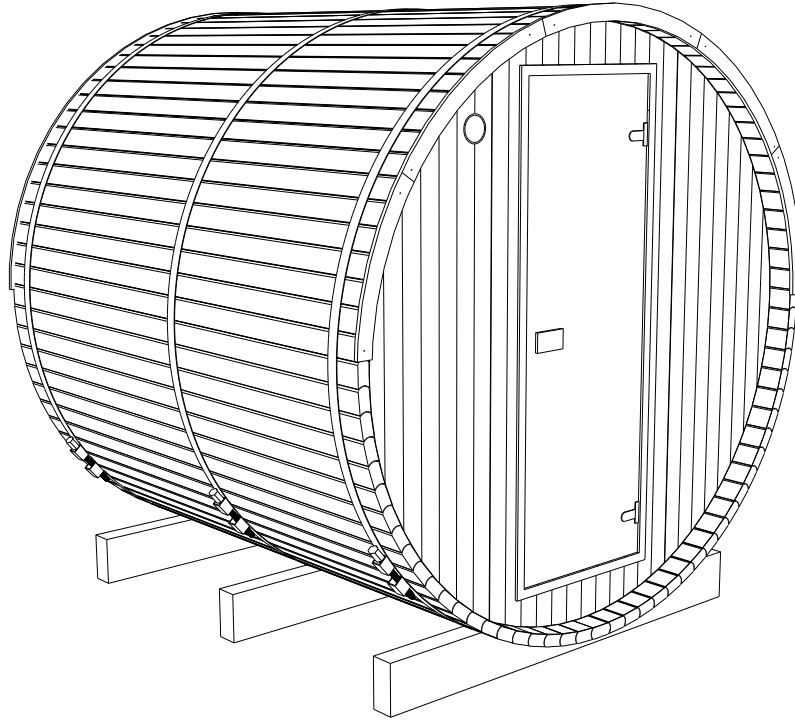

BARREL SAUNA

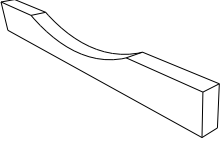
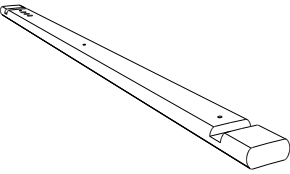
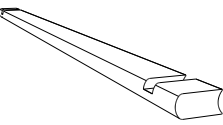
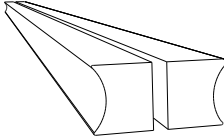
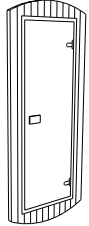
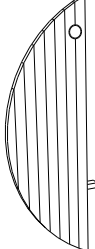
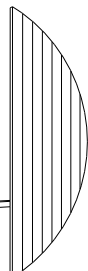
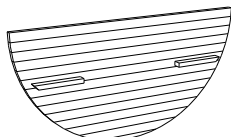
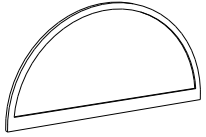
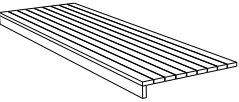
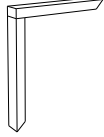
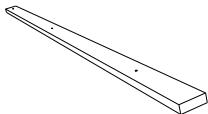

ASSEMBLY INSTRUCTION

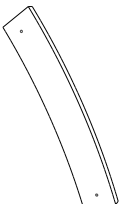
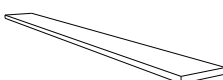
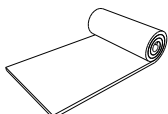
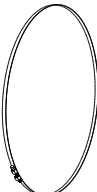
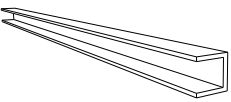

PART LIST

<p>A x3</p> 	<p>B x1</p> 	<p>C x70 (+2reserve)</p> 	<p>H x2</p> 
<p>cradles</p>	<p>center stave</p>	<p>body staves</p>	<p>final H tipe stave at the top</p>
<p>F2 x1</p> 	<p>F x1</p> 	<p>F1 x1</p> 	<p>V x1</p> 
<p>front panel</p>	<p>left panel section(front)</p>	<p>right panel section(front)</p>	<p>bottom rear panel</p>
<p>V1 x1</p> 	<p>J x2</p> 	<p>J1 x2</p> 	<p>J2 x6</p> 
<p>rear panel with panoramic window</p>	<p>sitting shelves</p>	<p>supporting leg</p>	<p>backrest staves</p>
<p>L x2</p> 	<p>W x10</p> 	<p>O x1</p> 	<p>R x1</p> 
<p>flooring duckboard</p>	<p>decorative roof finishing boards</p>	<p>aspen roof board</p>	<p>adhesive roof tape</p>
<p>I x3</p> 	<p>D x4</p> 	<p>M x8</p> 	<p>N</p> 
<p>metal bands</p>	<p>wooden cable raceway kit</p>	<p>screw 5.0x120</p>	<p>screw 4.2x70</p>

PART LIST

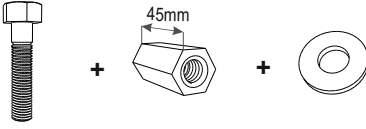
 <p>T x40</p>	 <p>P x36</p>	 <p>U x2 + x2 + x4</p>	PO- _____ _____ _____ Signature
screw 4.0x50	screw 4.0x35	bolt Ø16x140 hex nut M16 (SW24) flat washer	

BARREL DIMENSIONS

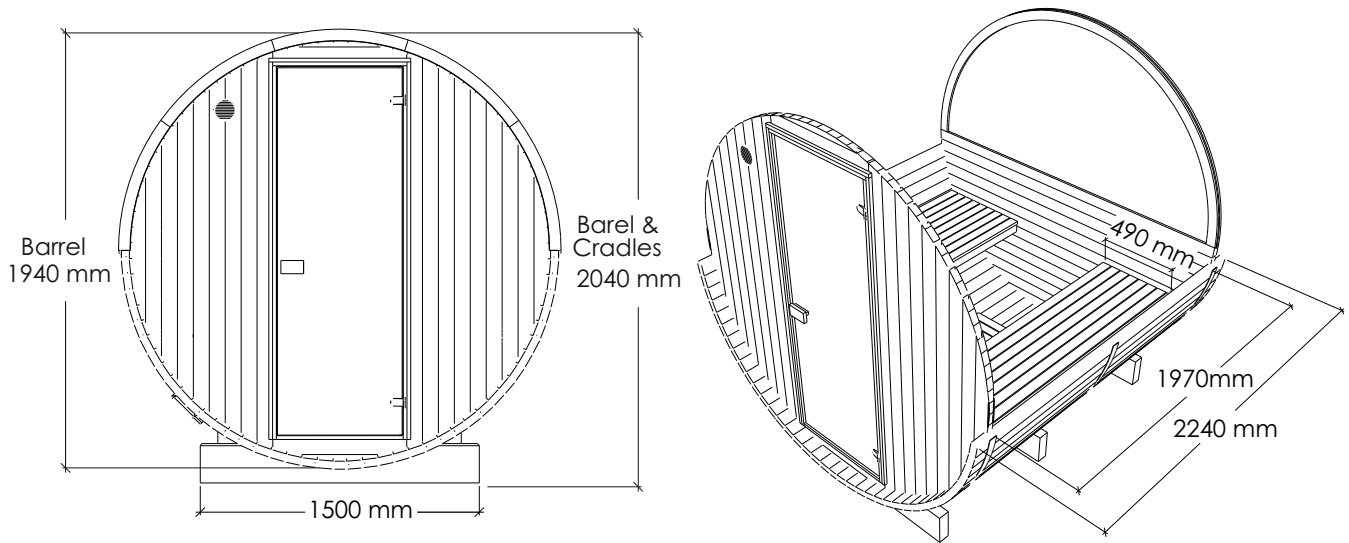

ADDITIONAL EQUIPMENT

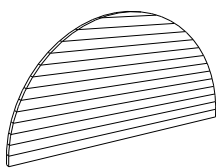

panel without window

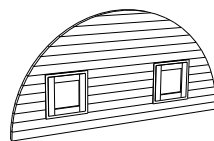

panel with two windows

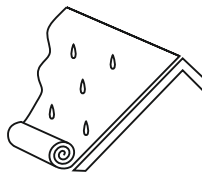

waterproof roof cover

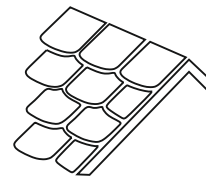

shingle roof cover



LED lighting

RECOMMENDATION



2 person recommended

TOOLS REQUIRED



STEP 1: Measure support cradles (A) diagonally from corner to corner. Measurements "a" and "b" should be equal to ensure the cradles are square. Be sure cradles remain level.

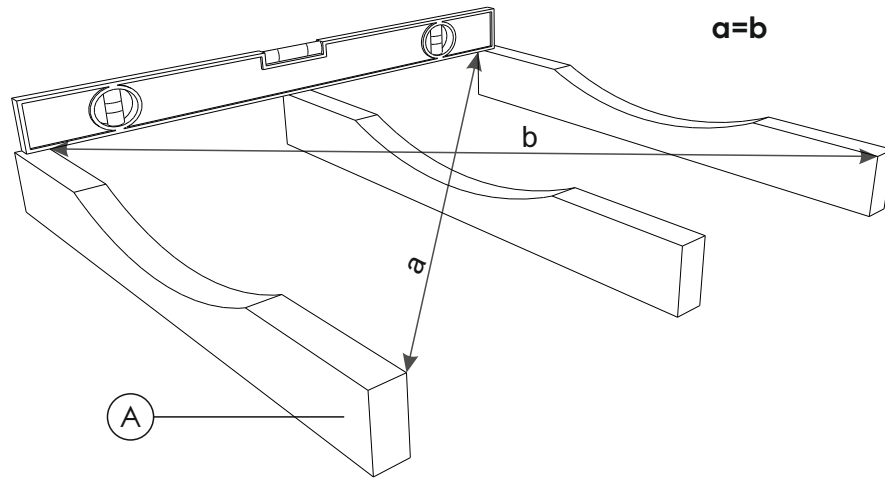

STEP 2: Place the support cradles (A) on level site. The middle support cradle will have no dowel. Carefully level for better stability. Place the center stave (B) on wooden dowels embedded in outer support cradles (A). Fix the center stave (B) with screw 4.2x70 (N).

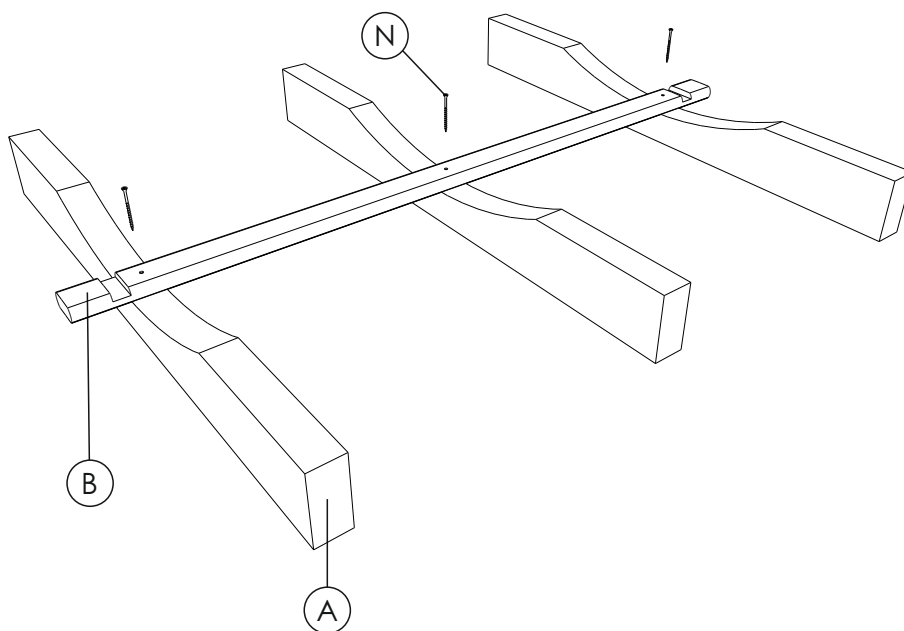

STEP 3: Place 6 sauna body staves (C) to each side of the center stave (B) and fix with screws 4.2 x 70 (N). Be sure to align the panel groove on every next body stave.

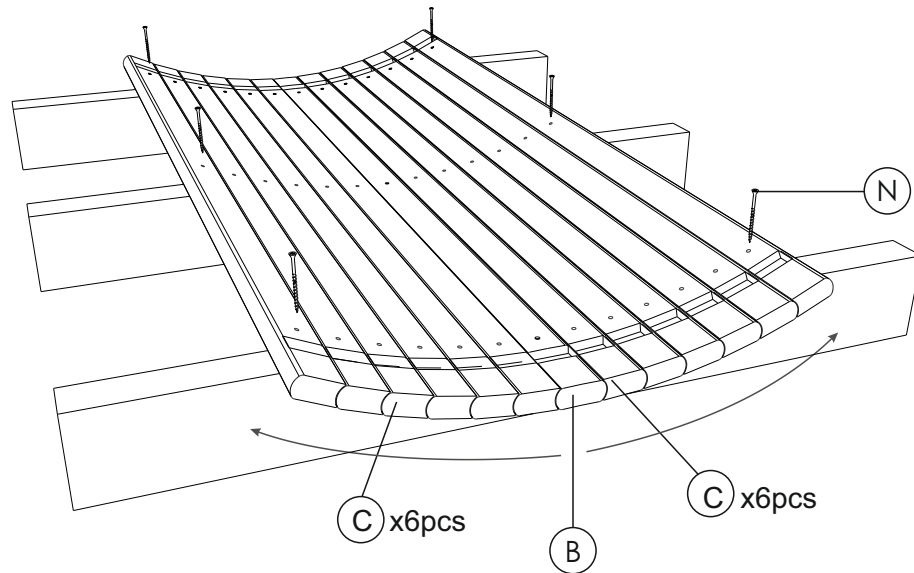

STEP 4: Place door panel (F2) in front slot. Be sure panel is centered, leveled, completely seated. Attach side panels (F, F1) using 4 5.0 x 120 (M) screws. Place rear panel (V) with bench supports facing interior. Confirm width of rear panel (E) matches combined width of left panel section (F), front panel (F2) and right panel section (F1). These panels must be completely seated into the floor panel.

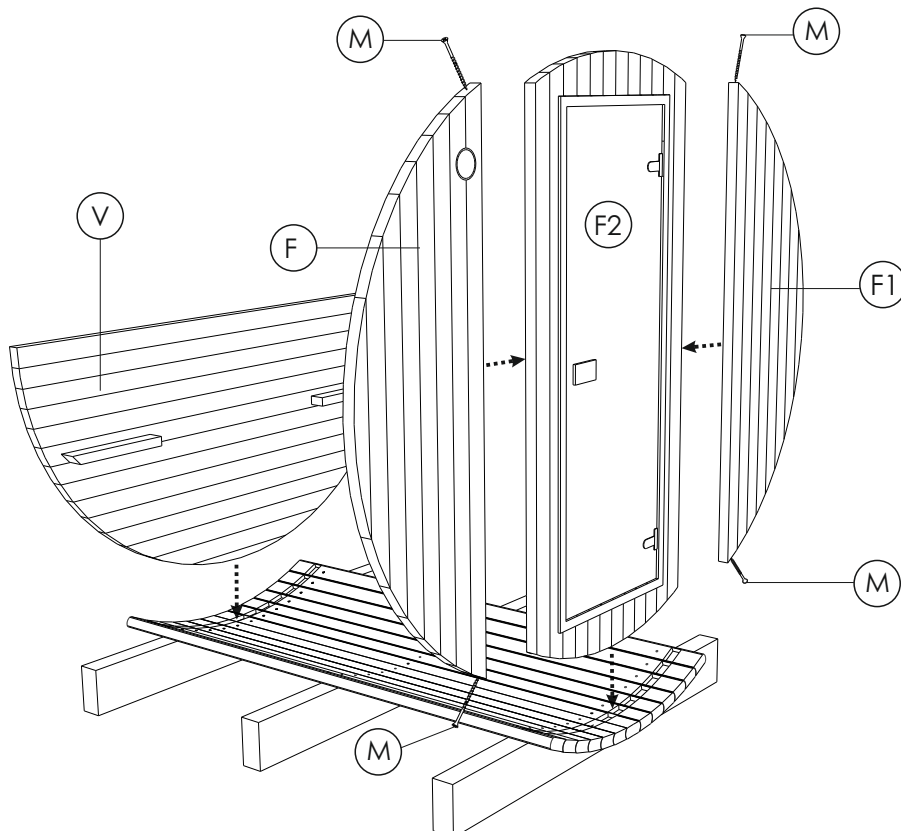

STEP 5: Place body staves (C) until the halfway point. Place rear panel with panoramic window (V1) on bottom rear panel (V), fix by 2 screws 5.0 x 120 (M). Bind panels (F2; V1) together by temporarily placing one or two body stave (C) on top of them.

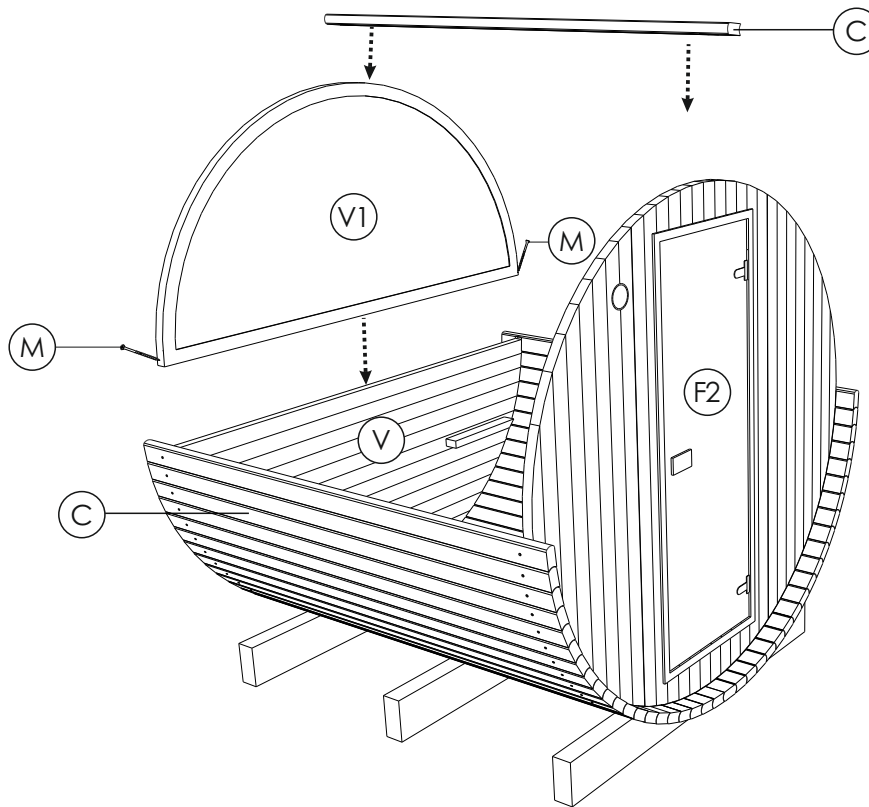

STEP 6: Continue placing body staves (C) tightly on both sides of the sauna using rubber mallet, while fixing body staves on the front panel with 4.2 x 70 screws (N) and rear window panel (V1) with 4.0 x 50 screws (T) to prevent glass breakage..To finish the roof top joint, use roof finishing item (H).

WARNING!
Use shorter screw 4.0 x 50 (T)
for rear panel E1 otherwise
the window will be damaged!

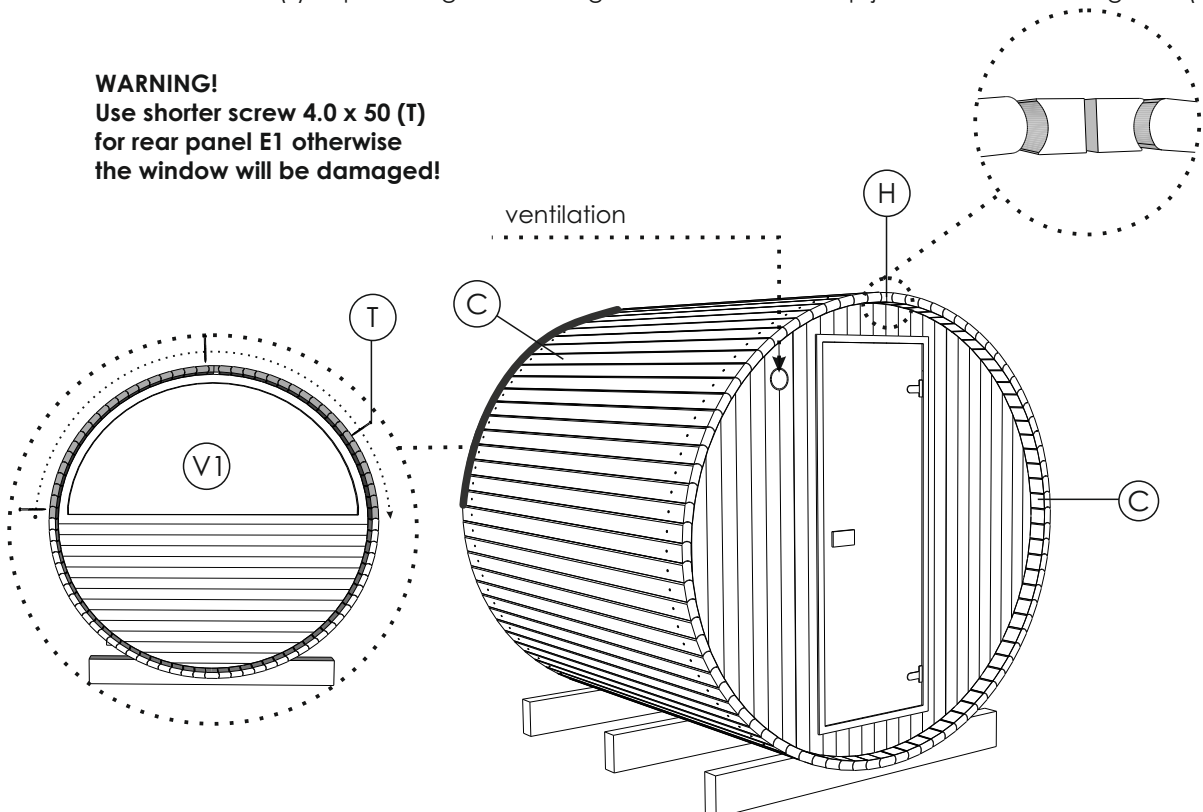

STEP 7: Measure steel bands (I) to ensure correct length of 100mm is acceptable. Install steel bands (I) by wrapping bands around barrel prior to connecting with bolts and nuts (U). Place steel bands evenly around barrel, covering screw heads. Measure from steel band to barrel edge to ensure the steel band is even. Cover roof with roof tape. Rub and smooth with pressure to ensure adhesion. Install interior aspen roof trim (O) with 4.0 x 35 (P) screws.

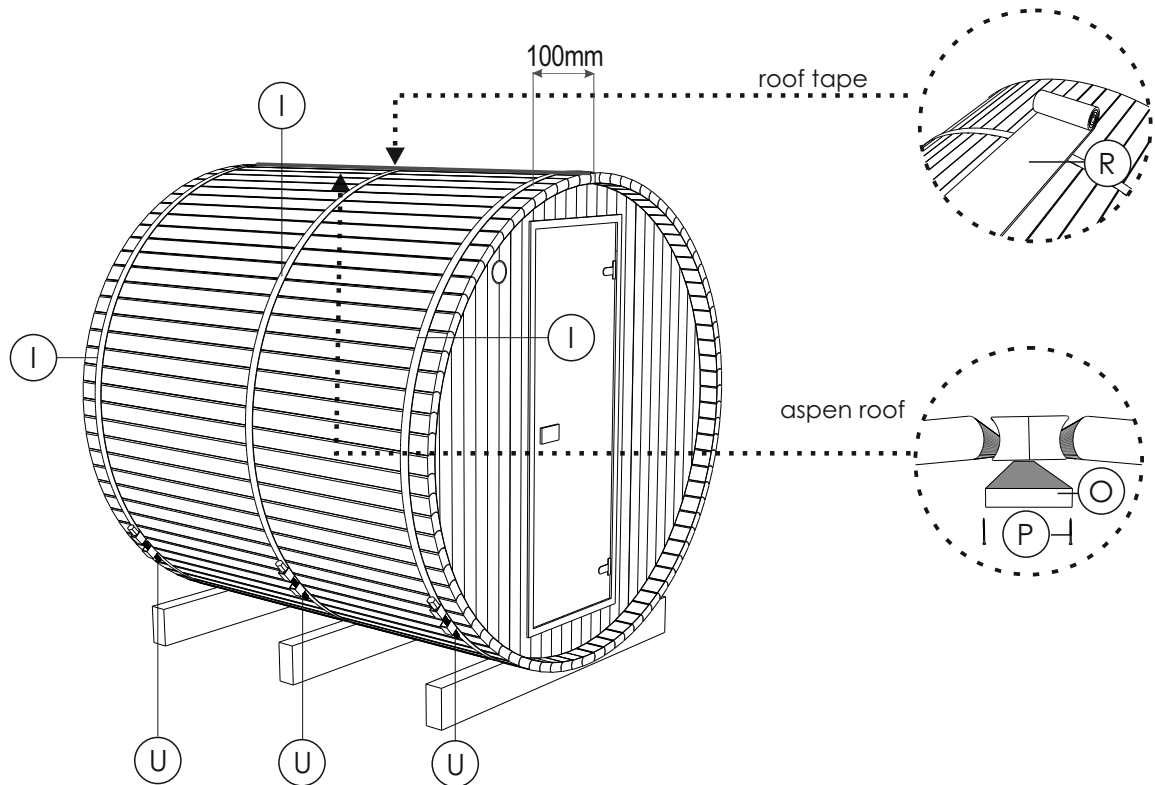

STEP 8: Attach interior supporting leg (J1) to the bench (J) using screw 4.0 x 35 (P). Install two sauna benches on wall mounts using screws 4.2 x 70 (N). Hold the seat and leg assembly tight to the sauna wall. Using a level, make sure the bench seat is level from front to back. This will ensure proper placement. Install backrests (J2) at your chosen height using screw 4.0 x 35 (P).

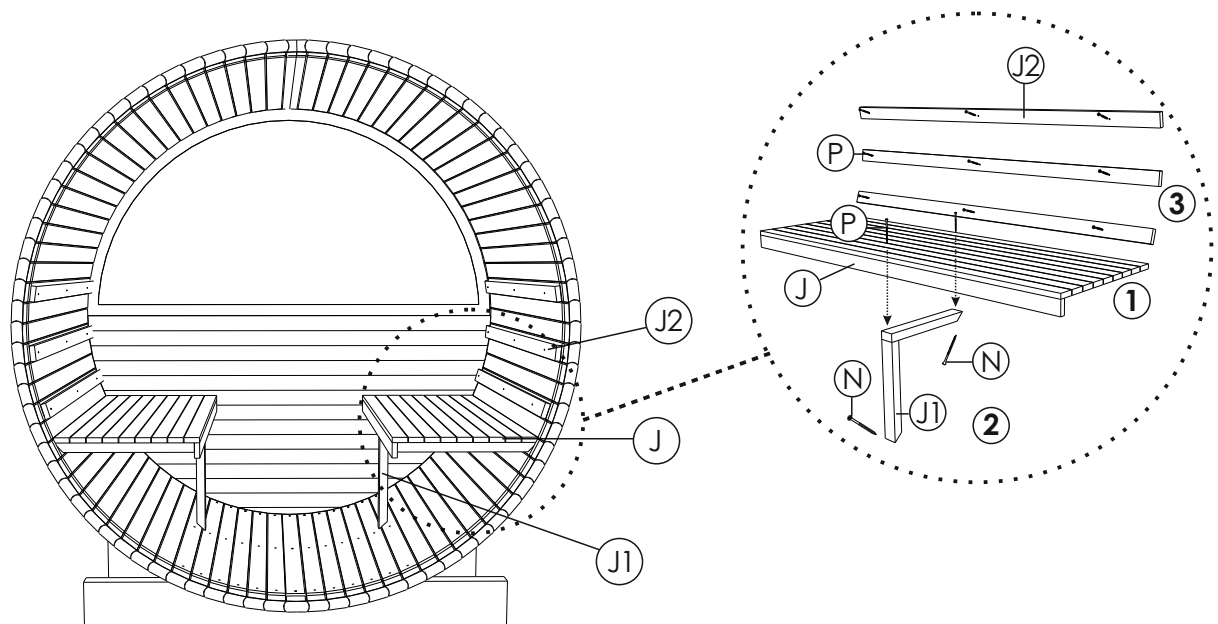

STEP 9: Install floor duckboards (L).

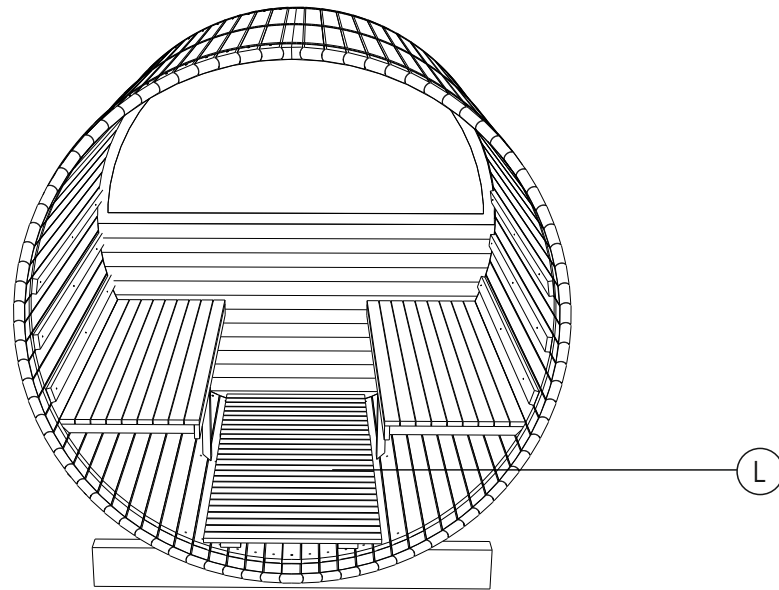

STEP 10: Install front and rear decorative roof finishing boards (W), fixing by screws 4.0x35(P).

