

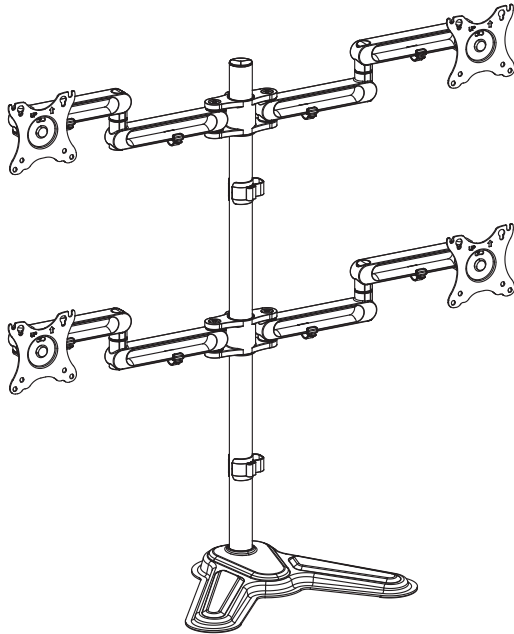

Quad Monitor Desk Stand

Instruction Manual



SKU: STAND-V104Z



Scan the QR code with your mobile device or follow the link for helpful videos and specifications related to this product.

<https://vivo-us.com/products/stand-v104z>

GET IN TOUCH | Monday-Friday from 7:00am-7:00pm CST



help@vivo-us.com



www.vivo-us.com
Chat live with an agent!



309-278-5303

WARNING!

If you do not understand these directions, or if you have any doubts about the safety of the installation, please call a qualified technician. Check carefully to make sure there are no missing or defective parts. Improper installation may cause damage or serious injury. Do not use this product for any purpose that is not explicitly specified in this manual. Do not exceed weight capacity. We cannot be liable for damage or injury caused by improper mounting, incorrect assembly or inappropriate use.

TIPOVER WARNING

SERIOUS OR FATAL CRUSHING INJURIES CAN OCCUR FROM TIPOVER. TO HELP PREVENT TIPOVER:

- NEVER ALLOW CHILDREN TO CLIMB, STAND, HANG, OR PLAY ON ANY PART OF MONITOR OR STAND.
- USE TIPOVER RESTRAINT OR ANCHOR STAND TO WALL

USE OF TIPOVER RESTRAINTS MAY ONLY REDUCE, BUT NOT ELIMINATE RISK OF TIPOVER.

WARNING: CHOKING HAZARD

SMALL PARTS - NOT FOR CHILDREN UNDER 3 YEARS. ADULT SUPERVISION IS REQUIRED.

PACKAGE CONTENTS

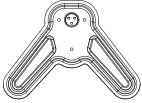

A (x1)
Base



B (x1)
Base Cover

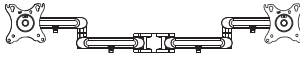

C (x2)
Monitor Arm



D (x1)
Pole



E (x2)
Cable Clip



F (x3)
M6x14



G (x1)
4mm Allen
Wrench



H (x1)
6mm Allen
Wrench



M-A (x16)
M4x12



M-B (x16)
M5x12



M-C (x16)
D5 Washer

NOTE: SOME HARDWARE INCLUDED MAY NOT BE USED

TOOLS NEEDED



DO NOT EXCEED WEIGHT CAPACITY.

Failure to do so may result in serious injury.



ASSEMBLY STEPS

STEP 1

Press the base cover (B) onto the base (A). Assemble the pole (D) to the base using M6x14 bolts (F) and tighten with the 4mm Allen wrench (G).

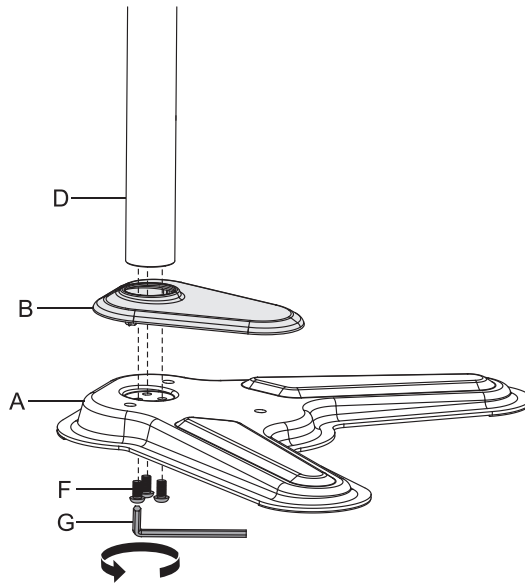

STEP 2

Slide the monitor arms (**C**) and cable clips (**E**) onto the pole to the desired height, and tighten the center brackets to the pole using the 6mm Allen wrench (**H**).

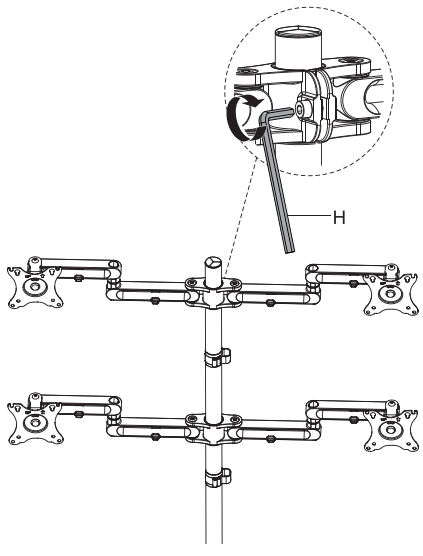
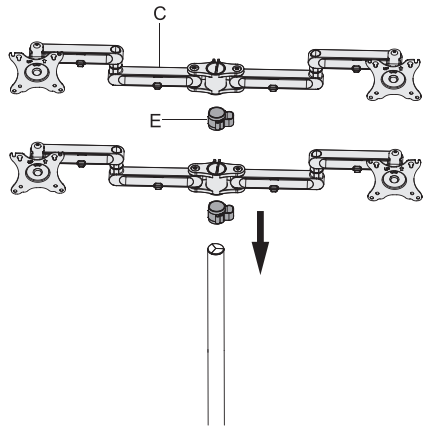

STEP 3

Attach two bolts (**M-A or M-B**) and washers (**M-C**) to the top mounting holes of each monitor, making sure to leave 3mm of thread exposed.

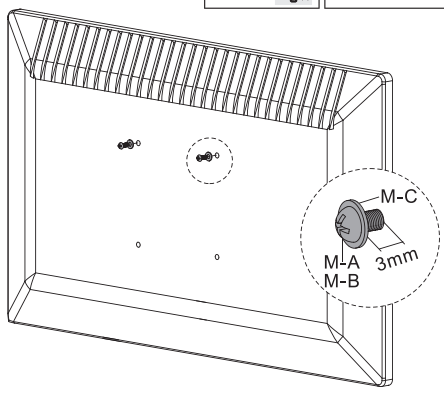

STEP 4

Align bolts (**M-A**, **M-B**) in VESA plates. Secure using two more bolts (**M-A or M-B**) and washers (**M-C**) in the bottom two holes of each monitor. Tighten all bolts using a Phillips screwdriver.

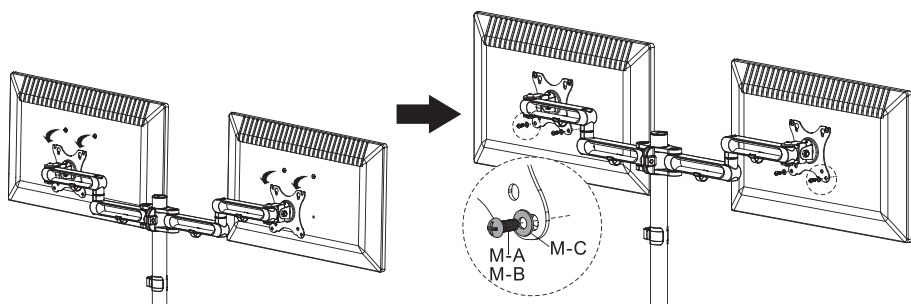
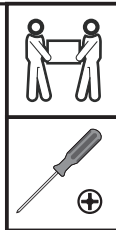

STEP 5

Tighten or loosen the tilt joints using the 6mm Allen wrench (**H**). Store tools in the cable clip.

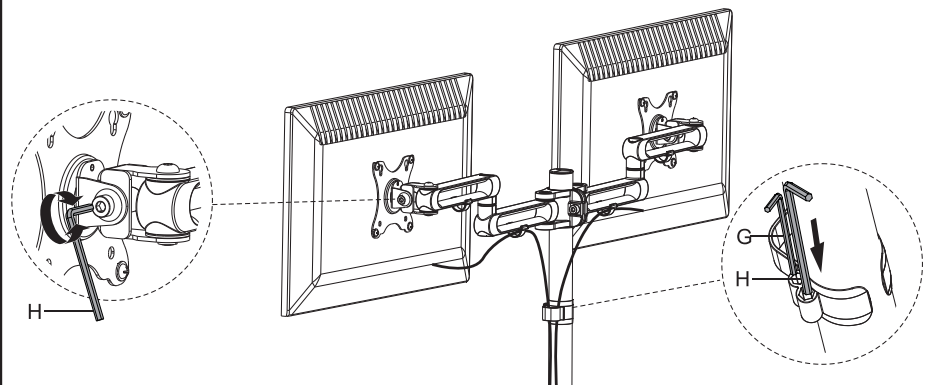

STEP 6

CAUTION: To prevent tipping, please be careful not to extend the arms too far forward or backward.

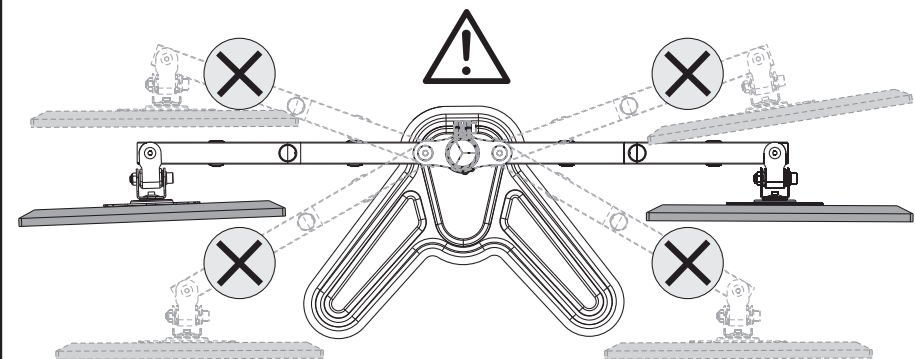

Adjust as Desired

Adjust monitor position and rotation as desired. Manage cables using the clips on the arms and pole.

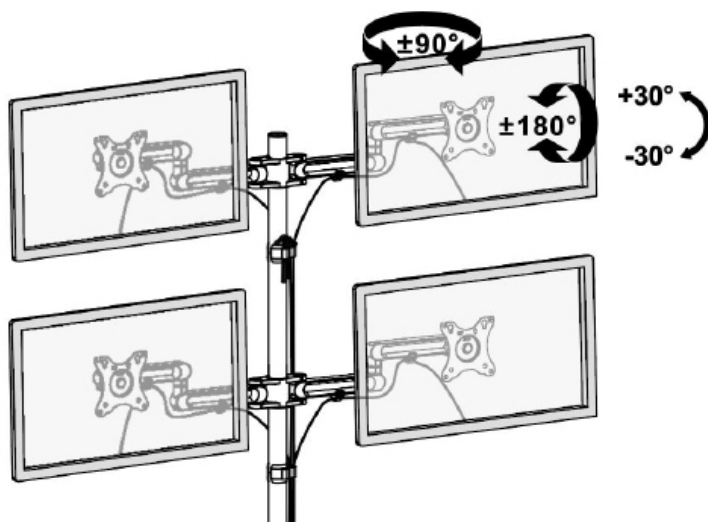



Open **Monday - Friday 7:00am - 7:00pm** CST,
our dedicated support team can offer immediate assistance with rapid response times. If any parts are received damaged or defective, please contact us. We are happy to replace parts to ensure you have a fully functioning product.

 help@vivo-us.com

AVG. RESPONSE TIME (*within office hrs*): **1HR 8M**

- 23% within < 15m
- 38% within < 30m
- 61% within < 1hr
- 83% within < 2hr
- 92% within < 3hr

 www.vivo-us.com
Chat live with an agent!

AVG. RESOLUTION TIME (*within office hrs*): **< 15 M**

 309-278-5303

AVG. RESOLUTION TIME (*within office hrs*): **5M 4S**