

Quad Monitor Desk Mount Instruction Manual

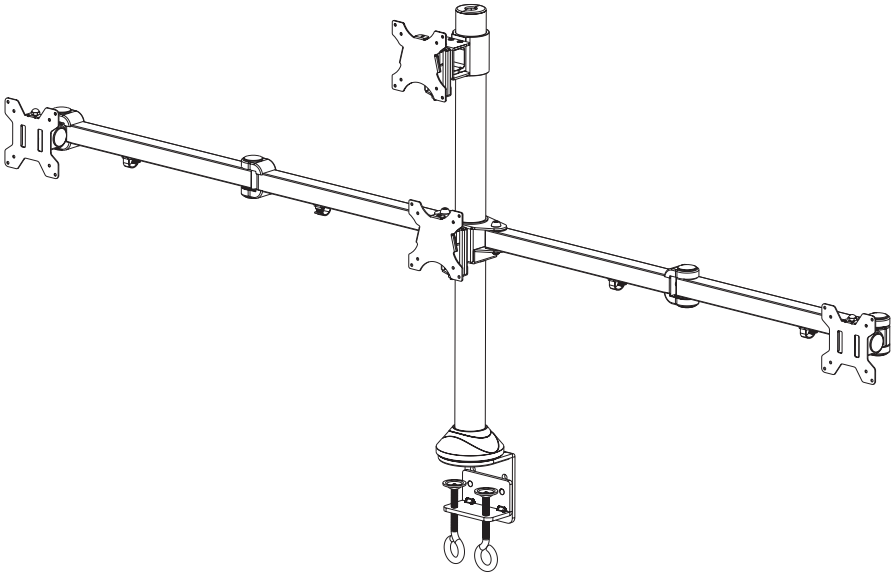

SKU: STAND-V104A



Scan the QR code with your mobile device or follow the link for helpful videos and specifications related to this product.

<https://vivo-us.com/products/stand-v104a>

GET IN TOUCH | Monday-Friday from 7:00am-7:00pm CST



help@vivo-us.com



www.vivo-us.com
Chat live with an agent!



309-278-5303

 **WARNING!**

If you do not understand these directions, or if you have any doubts about the safety of the installation, please call a qualified technician. Check carefully to make sure there are no missing or defective parts. Improper installation may cause damage or serious injury. Do not use this product for any purpose that is not explicitly specified in this manual. Do not exceed weight capacity. We cannot be liable for damage or injury caused by improper mounting, incorrect assembly or inappropriate use.

 **TIPOVER WARNING**

SERIOUS OR FATAL CRUSHING INJURIES CAN OCCUR FROM TIPOVER. TO HELP PREVENT TIPOVER:

- NEVER ALLOW CHILDREN TO CLIMB, STAND, HANG, OR PLAY ON ANY PART OF MONITOR OR STAND.
- USE TIPOVER RESTRAINT OR ANCHOR STAND TO WALL

USE OF TIPOVER RESTRAINTS MAY ONLY REDUCE, BUT NOT ELIMINATE RISK OF TIPOVER.

 **WARNING: CHOKING HAZARD**

SMALL PARTS - NOT FOR CHILDREN UNDER 3 YEARS. ADULT SUPERVISION IS REQUIRED.



DO NOT EXCEED WEIGHT CAPACITY.
Failure to do so may result in serious injury.

PER ARM

TOOLS NEEDED



PACKAGE CONTENTS

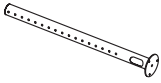

A (x1)
Pole



B (x1)
Clamp



C (x1)
Clamp Brace



D (x1)
Decorative
Cover

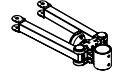

E (x1)
Center
Monitor Arm

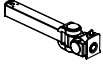

F (x2)
Monitor Arm



G (x1)
Mount



H (x1)
Support Plate



I (x1)
Foam Pad



J (x4)
Monitor Arm
Cover



K (x2)
Spare Cap



L (x4)
Plastic Spacer



M (x4)
Cable Clip



N (x2)
Side
VESA Plate



O (x2)
Center
VESA Plate



S-A (x2)
M10x47mm
Screw



S-B (x1)
M10x100mm
Screw



S-C (x3)
M6x10mm
Screw



S-D (x2)
M10x15mm
Screw



S-E (x4)
M8x10mm
Screw



S-F (x2)
Nut



S-G (x2)
M4x6mm
Screw



S-H (x1)
Spring Washer



S-I (x1)
M10 Washer



M-A (x16)
M4x12mm
Thumbscrew



M-B (x16)
M4x30mm
Screw



M-C (x16)
M4 Spacer



T-A (x1)
3mm Allen
Wrench

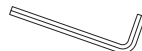

T-B (x1)
5mm Allen
Wrench

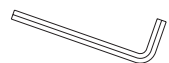

T-C (x1)
6mm Allen
Wrench



T-D (x1)
Wrench

NOTE: SOME HARDWARE INCLUDED MAY NOT BE USED

ASSEMBLY STEPS

STEP 1 - Clamp Installation

Install Pole (A) to Clamp Brace (C) using M6x10mm Screws (S-C) and a Phillips screwdriver.

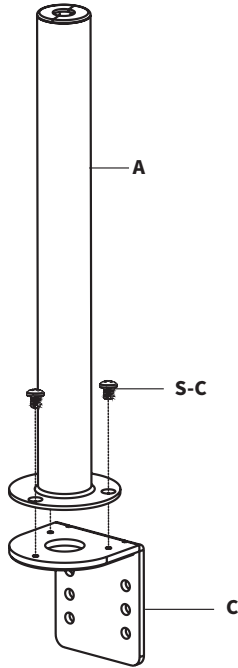

Assemble Clamp (B) to Clamp Brace (C) using M10x15mm Screws (S-D) and 6mm Allen Wrench (T-B). Secure the clamp assembly to the desktop by tightening to the hand bolts on Clamp (B). Install the Pole Cover (D) to Pole (A).

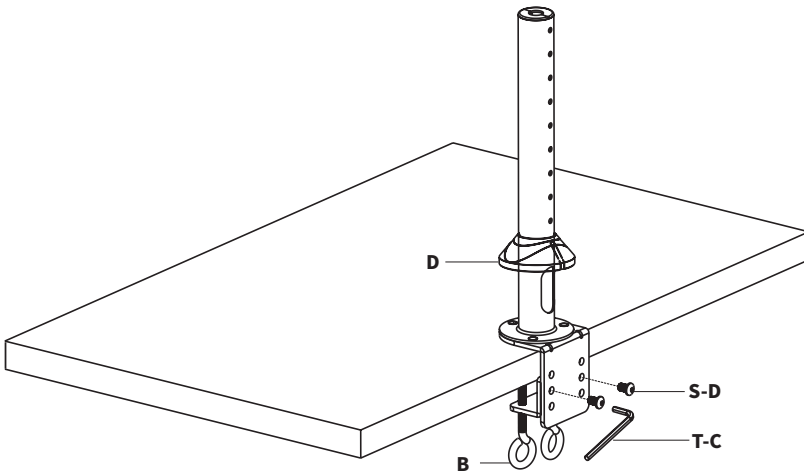

STEP 1 - Grommet Installation

Remove adhesive backing from Foam Pad Pad **(I)** and place on the bottom of Pole **(A)**.

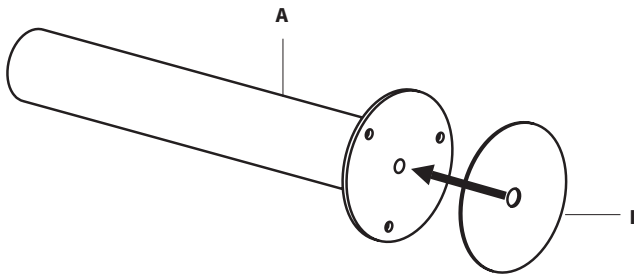

Install Pole **(A)** to existing grommet hole using Support Plate **(H)** with M10x100mm Screw **(S-B)**, M10 Washer **(S-I)** and Spring Washer **(S-H)**. Tighten with Wrench **(T-D)**. Install the Pole Cover **(D)** to Pole **(A)**.

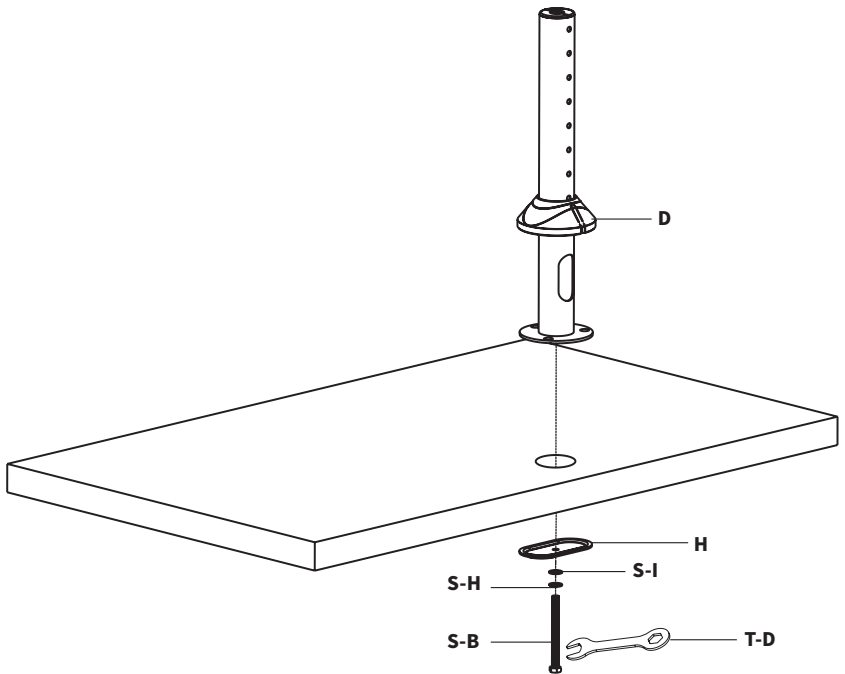

If no grommet hole exists, drill a 3/8" (10mm) diameter hole through the mounting surface.

STEP 2

Lay Monitor Arm (F) on flat surface with holes for cable clips facing down. Add Plastic Spacers (L) to holes at ends of Monitor Arm (F).

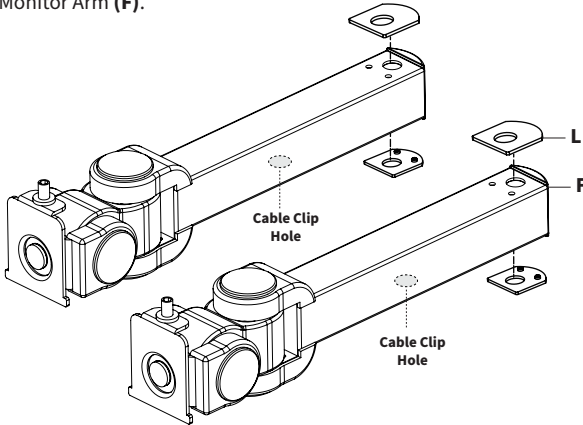

NOTE: Transparent monitor arm image used to show cable clip holes. Holes are on the underside of arms and are not visible when arm is facing upright.

Align Monitor Arm and Center Monitor Arm (E,F) so that the holes for the cable clips are facing down. Insert Monitor Arms (F) into Center Monitor Arm (E) as shown below. Secure using M10x47mm Screws (S-A) and 6mm Allen Wrench (T-C).

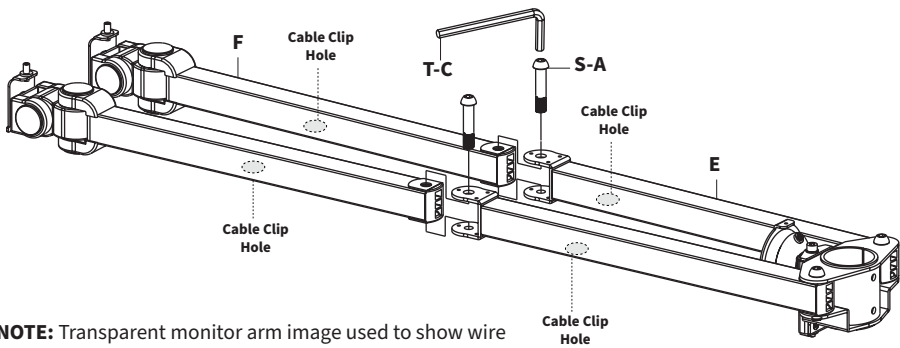

NOTE: Transparent monitor arm image used to show wire clip holes. Holes are on the underside of arms and are not visible when arm is facing upright.

Press Monitor Arm Covers (J) onto the top and bottom of arm joints. Place Cable Clips (M) into wire clip holes.

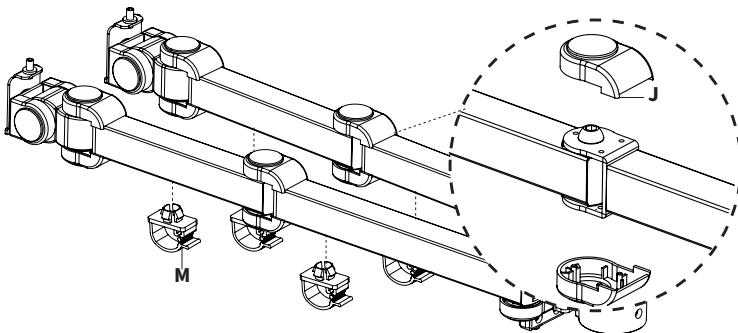

STEP 3

Slide arm assembly onto Pole (A) at desired height and secure using M8x10mm Screws (S-E) and 5mm Allen Wrench (T-B).

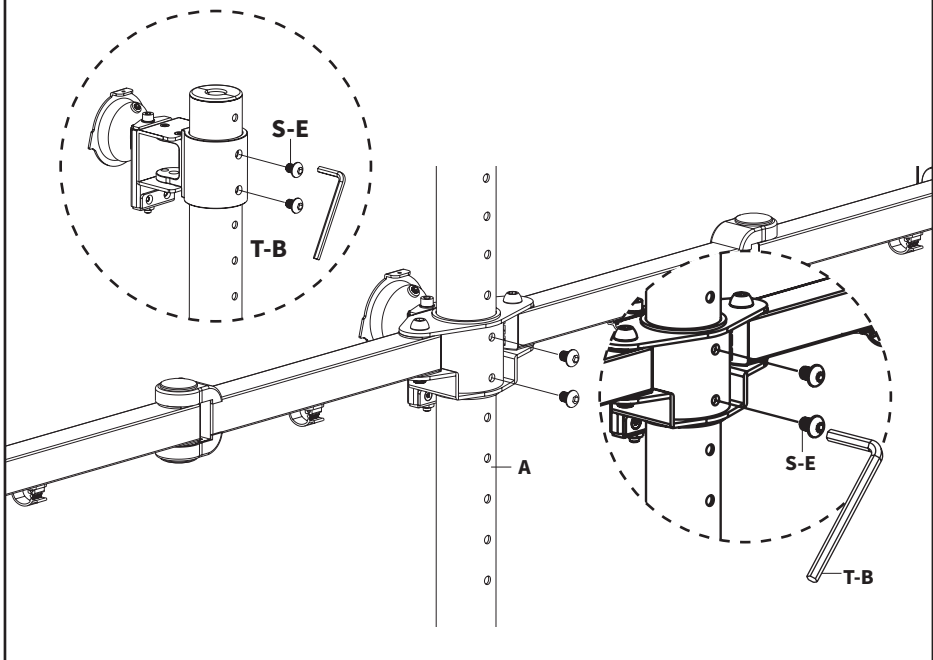

STEP 4a - Flat Back Monitors

Attach the Center VESA Plates (P) to the monitors you intend to mount in the center of the mount. Attach Side VESA Plates (O) to remaining monitors. Secure using M4x12mm Screws (M-A).

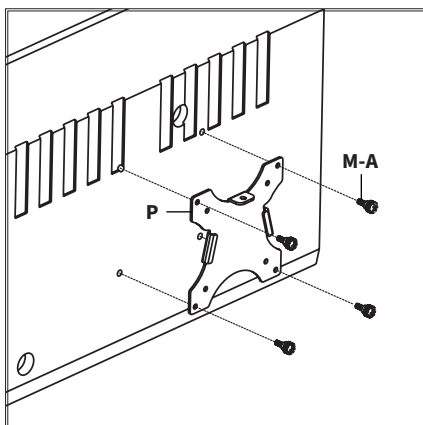

Center VESA Plate (P) Installation

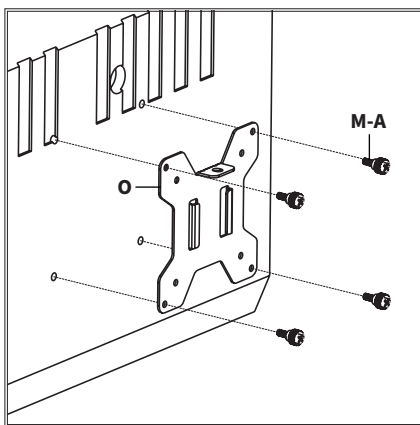

Side VESA Plate (O) Installation

NOTE: Hand tighten screws to avoid stripping the plastic screw heads.

STEP 4b - Curved/Recessed Back Monitors

Attach the Center VESA Plates (**O**) to the monitors you intend to mount in the center of the mount. Attach Side VESA Plates (**N**) to remaining monitors. Secure using M4 Spacers (**M-C**), M4x30mm Screws (**M-B**) and a Phillips screwdriver.

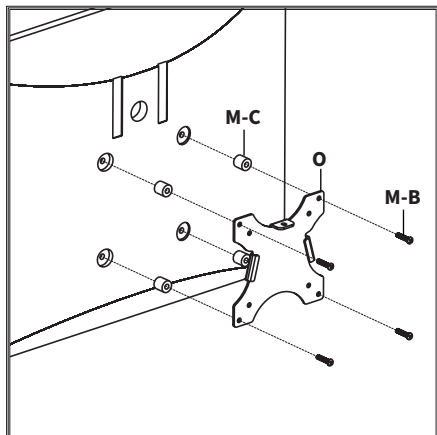

Center VESA Plate (**O**) Installation

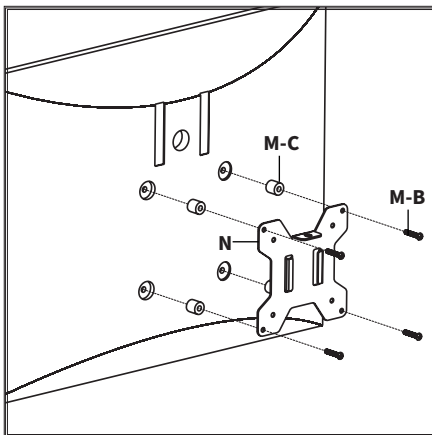

Side VESA Plate (**N**) Installation

STEP 5

Slide the center monitors onto the Center Head (**E1**) and Mount (**G**). Install M4x6mm Screws (**S-G**) to secure the monitors.

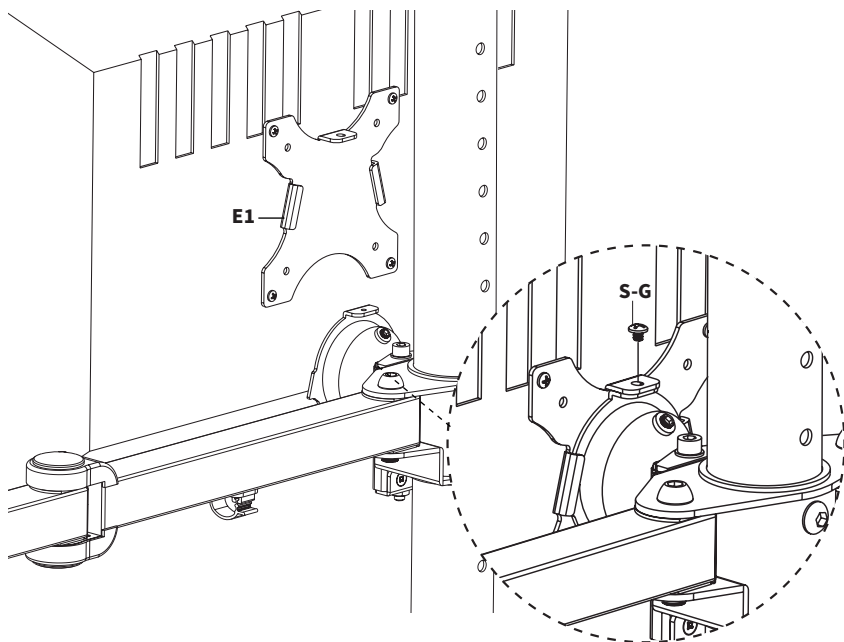

STEP 6

Slide the outer monitors onto Outer VESA Heads (**F1**). Secure with Cap Nut (**S-F**).

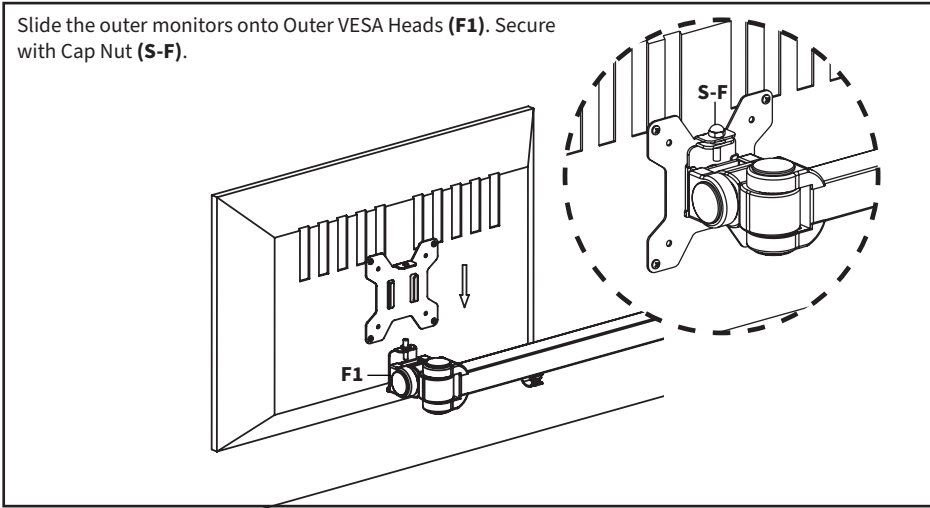

Adjust Monitor Tilt

Pry off Plastic Covers (**F2**) from the Outer VESA Heads (**F1**). The exposed nut on the side is used to adjust the tilt. Tighten the nut using Wrench (**T-D**) to adjust. Replace Plastic Covers (**F2**).

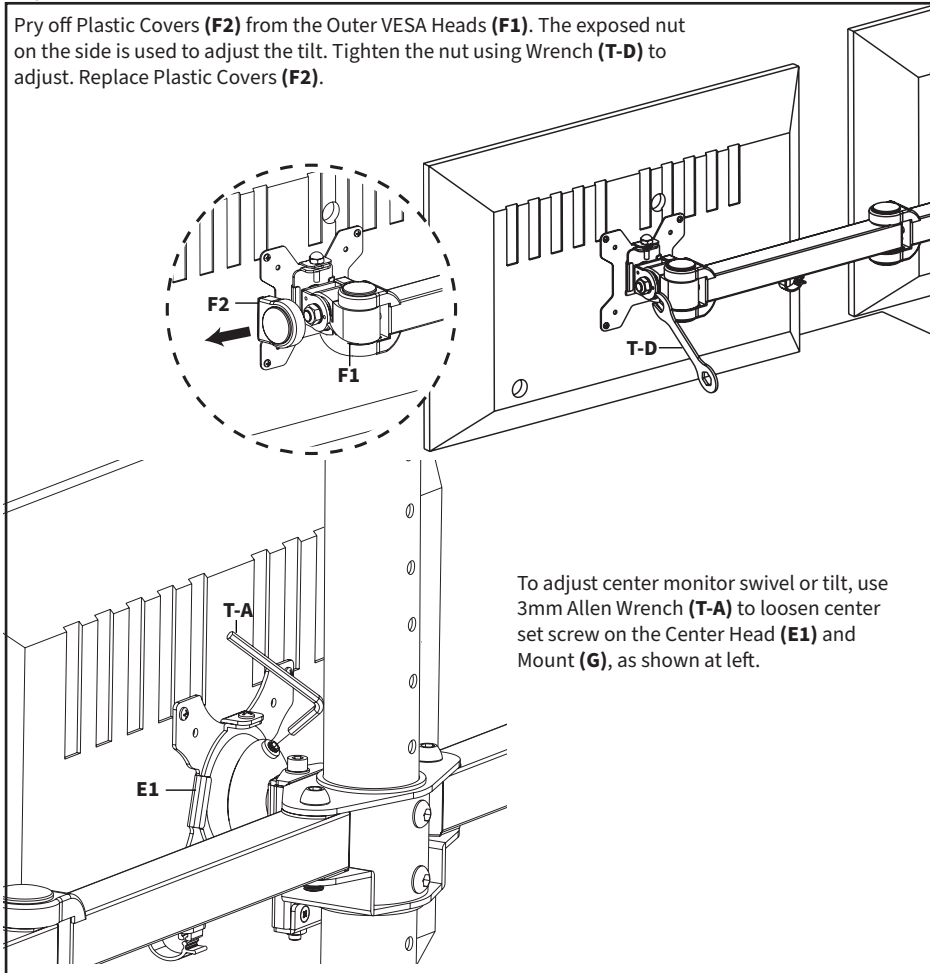

To adjust center monitor swivel or tilt, use 3mm Allen Wrench (**T-A**) to loosen center set screw on the Center Head (**E1**) and Mount (**G**), as shown at left.

Adjust Monitor Height

To adjust center monitor height, turn the screw behind Center Head (**E1**) and Mount (**G**) using the 5mm Allen Wrench (**T-B**).

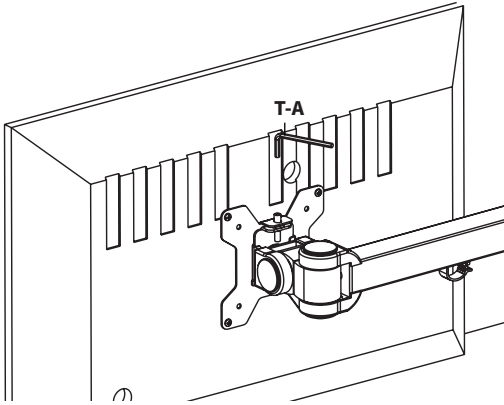
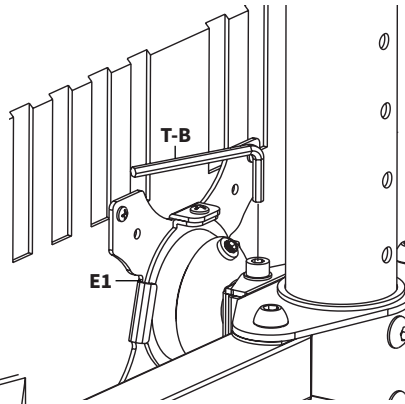

To level the side monitors, remove the Cap Nut (**S-F**) and turn the inner bolt with the 3mm Allen Wrench (**T-A**) to raise or lower the monitor. Replace Nut after the adjustment.

To adjust swivel joint tension, remove the Monitor Arm Cover (**J**) and turn the bolt underneath with the 6mm Allen Wrench (**T-C**).

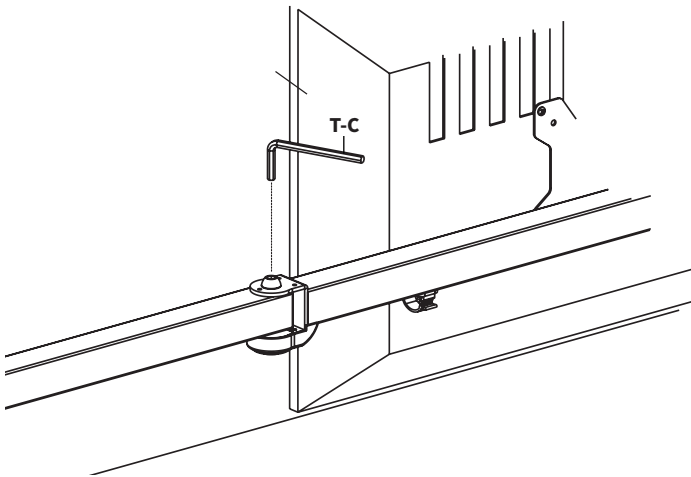

Cable Management

Manage cables using Cable Clips (**M**) on assembled arms. Remove the split cap from the Pole (**A**) and feed cables through, pulling ends out from the opening in back. Replace the split cap when finished.

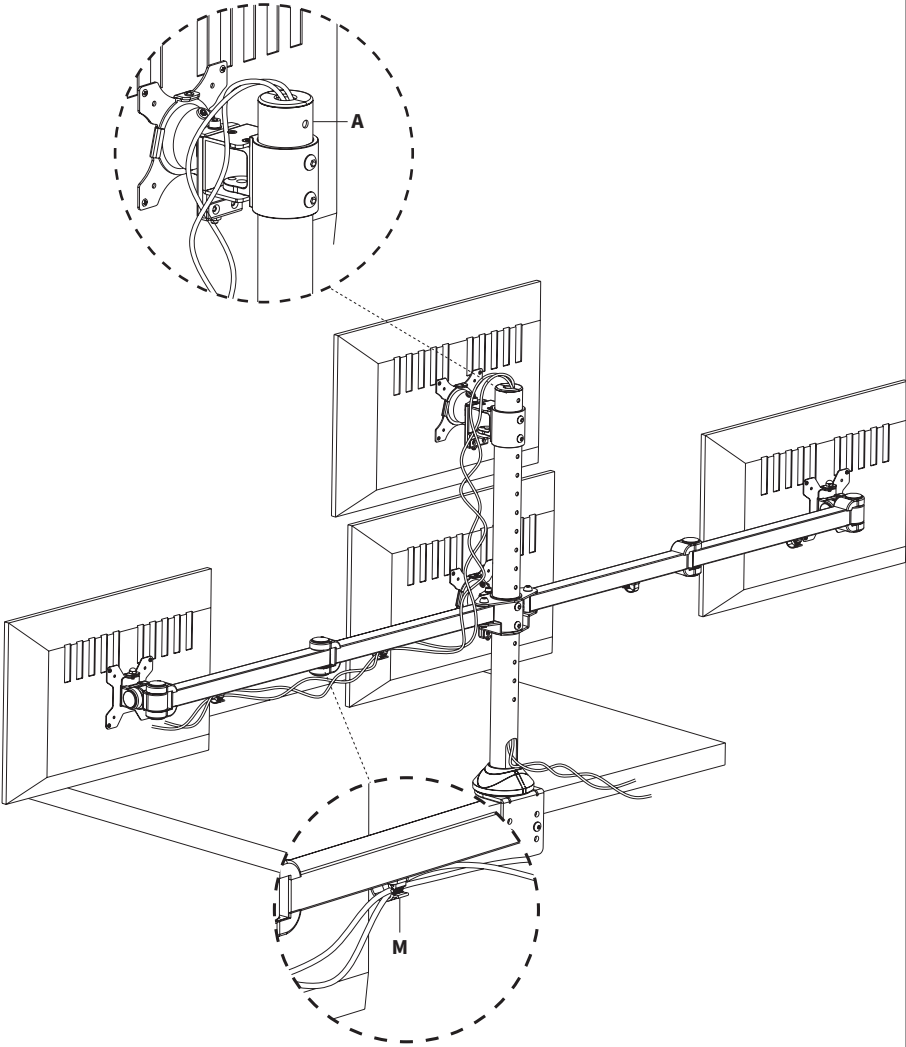



Love your new VIVO setup and want to share?
Tag us in your photo! [@vivo_us](#)

LAST UPDATED: 11/07/2023
REV2



Open **Monday - Friday 7:00am - 7:00pm** CST,
our dedicated support team can offer immediate assistance with rapid response times. If any parts are received damaged or defective, please contact us. We are happy to replace parts to ensure you have a fully functioning product.



309-278-5303

AVG. RESOLUTION TIME (*within office hrs*): **5M 4S**



www.vivo-us.com
Chat live with an agent!

AVG. RESOLUTION TIME (*within office hrs*): **< 15 M**



help@vivo-us.com

AVG. RESPONSE TIME (*within office hrs*): **1HR 8M**

- 23% within < 15m
- 38% within < 30m
- 61% within < 1hr
- 83% within < 2hr
- 92% within < 3hr

FOR MORE VIVO PRODUCTS, CHECK OUT OUR WEBSITE AT: www.vivo-us.com