

Dual Monitor Desk Stand

Instruction Manual

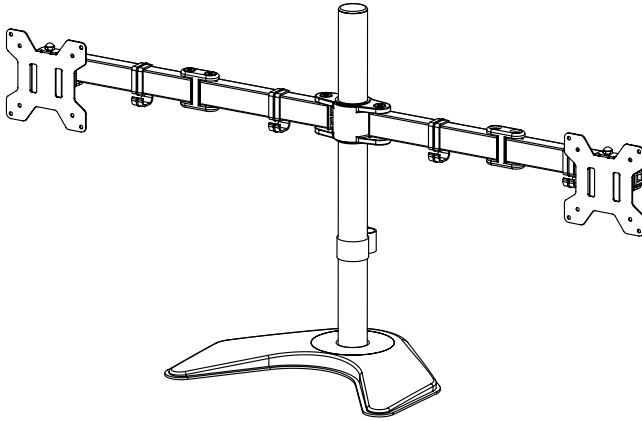

SKU: STAND-V102K



Scan the QR code with your mobile device or follow the link for helpful videos and specifications related to this product.

<https://vivo-us.com/products/stand-v102k>

GET IN TOUCH | Monday-Friday from 7:00am-7:00pm CST



help@vivo-us.com



www.vivo-us.com
Chat live with an agent!



309-278-5303

WARNING!

If you do not understand these directions, or if you have any doubts about the safety of the installation, please call a qualified technician. Check carefully to make sure there are no missing or defective parts. Improper installation may cause damage or serious injury. Do not use this product for any purpose that is not explicitly specified in this manual. Do not exceed weight capacity. We cannot be liable for damage or injury caused by improper mounting, incorrect assembly or inappropriate use.

TIPOVER WARNING

SERIOUS OR FATAL CRUSHING INJURIES CAN OCCUR FROM TIPOVER. TO HELP PREVENT TIPOVER:

- **TO PREVENT TIPPING, PLEASE BE CAREFUL NOT TO EXTEND THE ARMS TOO FAR FORWARD OR BACKWARD.**
- NEVER ALLOW CHILDREN TO CLIMB, STAND, HANG, OR PLAY ON ANY PART OF MONITOR OR STAND.
- USE TIPOVER RESTRAINT OR ANCHOR STAND TO WALL

USE OF TIPOVER RESTRAINTS MAY ONLY REDUCE, BUT NOT ELIMINATE RISK OF TIPOVER.

WARNING: CHOKING HAZARD

SMALL PARTS - NOT FOR CHILDREN UNDER 3 YEARS. ADULT SUPERVISION IS REQUIRED.

PACKAGE CONTENTS

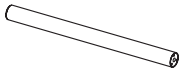

a (x1)
Pole



b (x1)
Weighted Base

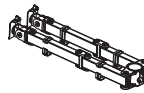

c (x1)
Swivel Arm



d (x2)
VESA Plate



e (x3)
M5x14



f (x2)
Nut



g1 (x1)
Wire Clip



g2 (x4)
Wire Clip

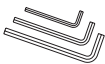

h (x1)
Allen Wrench
Set



i (x8)
M4x12



j (x8)
M4x30



k (x8)
M4 Spacer

NOTE: SOME HARDWARE INCLUDED MAY NOT BE USED

TOOLS NEEDED



DO NOT EXCEED WEIGHT CAPACITY.

Failure to do so may result in serious injury.

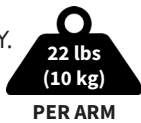

ASSEMBLY STEPS

STEP 1

Install the pole (**a**) to the base (**b**) using M5x14 bolts (**e**).
Tighten with the small Allen wrench (**h**).

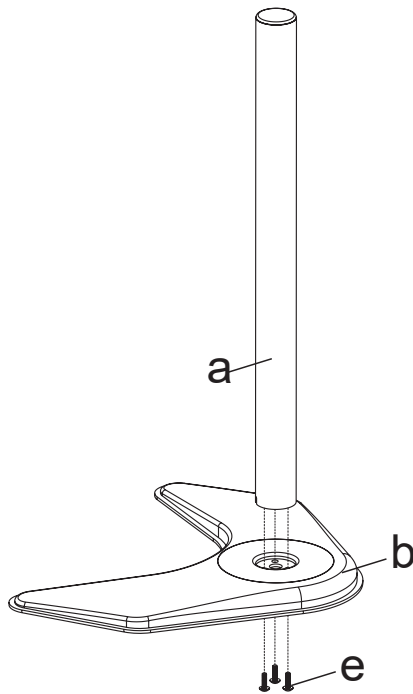

STEP 2

Slide swivel arm (c) down onto the pole and tighten the bolt with large Allen wrench (h). Attach the wire clips (g1, g2) to the pole and swivel arm.

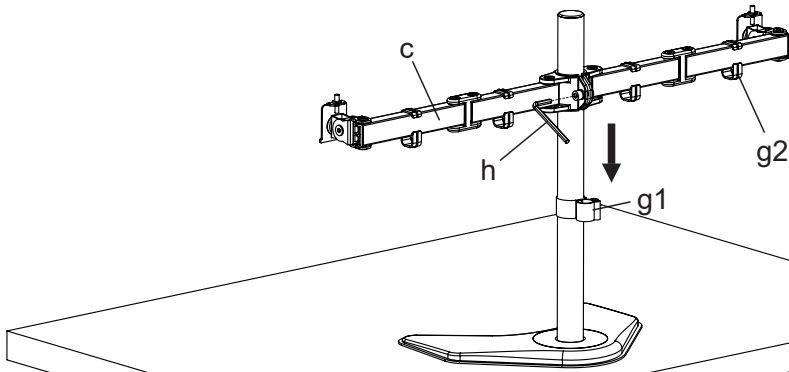

STEP 3

OPTION A: Flat Back Monitor

Attach the VESA plates (d) to the monitors using M4x12 thumb bolts (i).

NOTE: Hand tighten screws to avoid stripping the plastic screw heads.

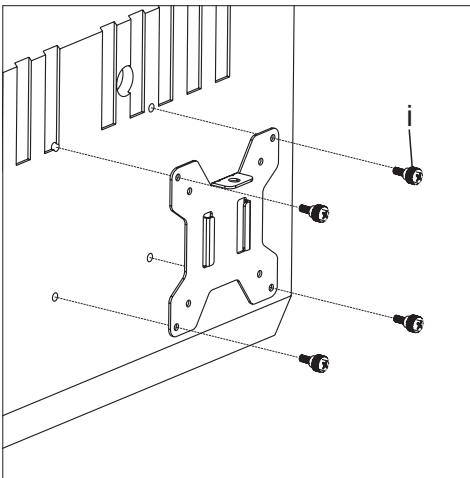

STEP 3 (Continued)

OPTION B: Curved Back TV

Attach the VESA plates (**d**) to the monitors using M4 spacers (**k**) and M4x30 bolts (**j**). Tighten with a Phillips screwdriver.

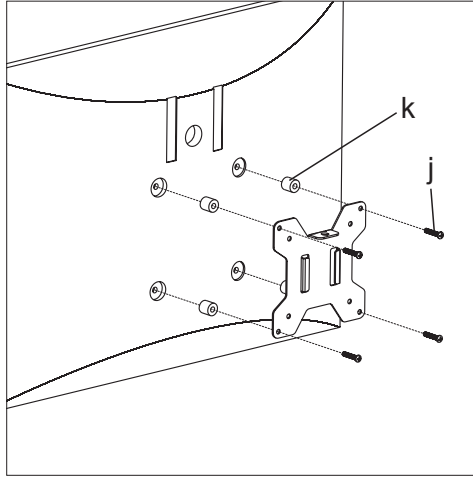

STEP 4

Slide the monitors onto the heads of swivel arm and install the security nuts (**f**). Make sure the security nuts are installed before you rotate the monitors.

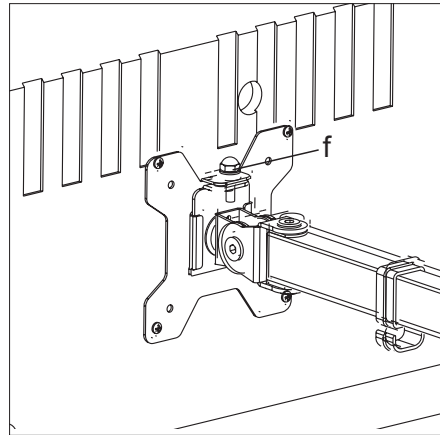
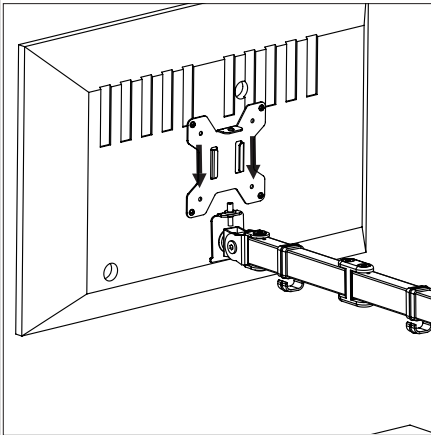

STEP 5

Tighten the bolt on the side of the tilt joint with the medium Allen wrench (**h**) to fix the tilt angle. To level the monitors, remove the security nut and turn the bolt with the small Allen wrench (**h**) to raise or lower the monitor. Replace nut after the adjustment.

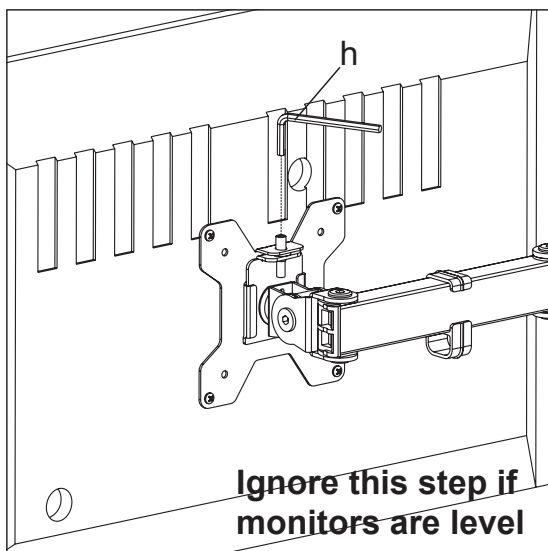
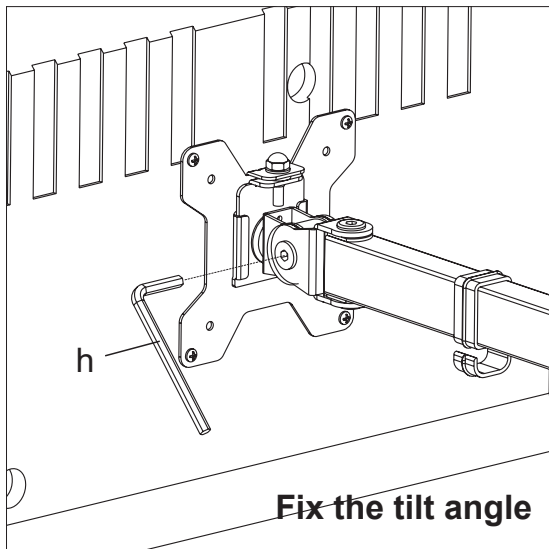

STEP 6

Use the medium Allen wrench (**h**) to adjust swivel joints if needed. Manage cables and store the Allen wrenches (**h**) in wire clip (**g1**) for future use.

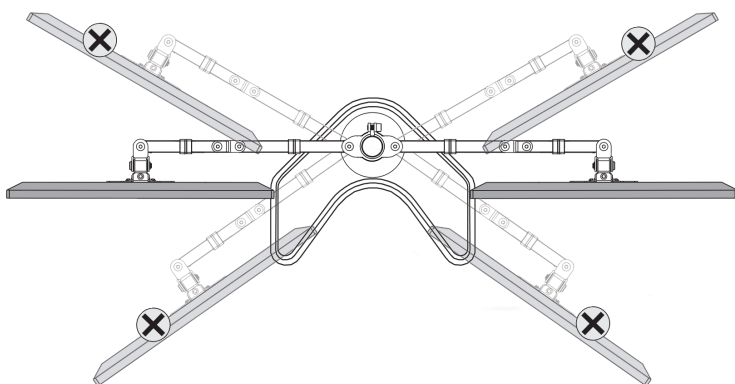
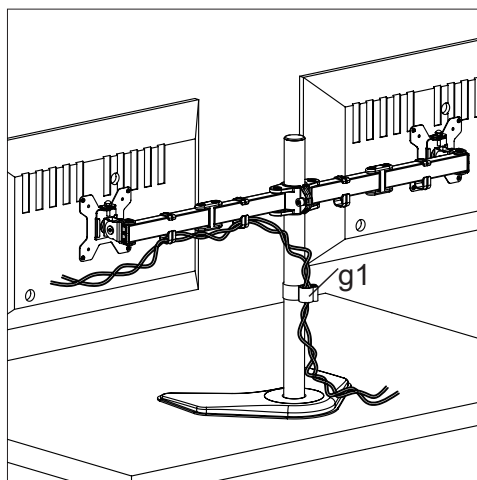
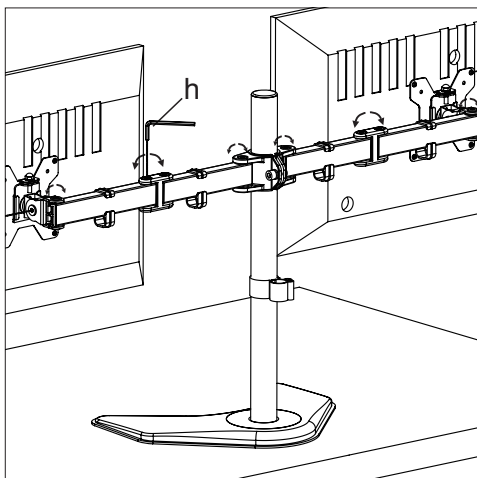

CAUTION: To prevent tipping, please be careful not to extend the arms too far forward or backward.



Open **Monday - Friday 7:00am - 7:00pm** CST,

our dedicated support team can offer immediate assistance with rapid response times. If any parts are received damaged or defective, please contact us. We are happy to replace parts to ensure you have a fully functioning product.

 help@vivo-us.com

AVG. RESPONSE TIME (*within office hrs*): **1HR 8M**

- 23% within < 15m
- 38% within < 30m
- 61% within < 1hr
- 83% within < 2hr
- 92% within < 3hr

 www.vivo-us.com
Chat live with an agent!

AVG. RESOLUTION TIME (*within office hrs*): **< 15 M**

 309-278-5303

AVG. RESOLUTION TIME (*within office hrs*): **5M 4S**