

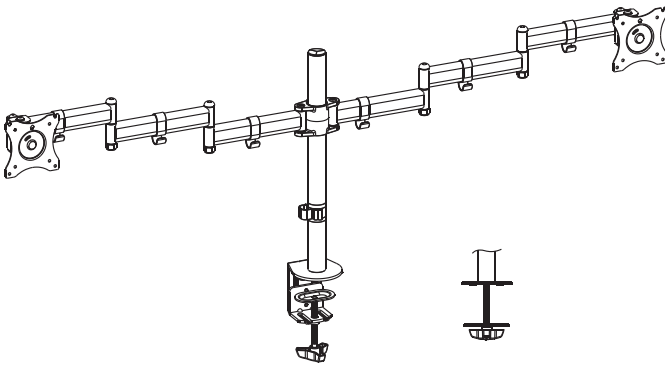

Dual Monitor Desk Mount

Instruction Manual



SKU: STAND-V038M



Scan the QR code with your mobile device or follow the link for helpful videos and specifications related to this product.

<https://vivo-us.com/products/stand-v038m>

GET IN TOUCH | Monday-Friday from 7:00am-7:00pm CST



help@vivo-us.com



www.vivo-us.com
Chat live with an agent!



309-278-5303

⚠️ WARNING!

If you do not understand these directions, or if you have any doubts about the safety of the installation, please call a qualified technician. Check carefully to make sure there are no missing or defective parts. Improper installation may cause damage or serious injury. Do not use this product for any purpose that is not explicitly specified in this manual. Do not exceed weight capacity. We cannot be liable for damage or injury caused by improper mounting, incorrect assembly or inappropriate use.

⚠️ TIPOVER WARNING

SERIOUS OR FATAL CRUSHING INJURIES CAN OCCUR FROM TIPOVER. TO HELP PREVENT TIPOVER:

























- NEVER ALLOW CHILDREN TO CLIMB, STAND, HANG, OR PLAY ON ANY PART OF MONITOR OR STAND.
- USE TIPOVER RESTRAINT OR ANCHOR STAND TO WALL

USE OF TIPOVER RESTRAINTS MAY ONLY REDUCE, BUT NOT ELIMINATE RISK OF TIPOVER.

⚠️ WARNING: CHOKING HAZARD

SMALL PARTS - NOT FOR CHILDREN UNDER 3 YEARS. ADULT SUPERVISION IS REQUIRED.

PACKAGE CONTENTS

					
A (x1) Arm	B (x1) Pole	C (x1) Pole Cap	D (x1) Clamp	E (x2) VESA Bracket	
					
F (x1) Grommet Plate	G (x5) Soft Pad	H (x1) Support Plate	I (x6) Arm Cable Clip	J (x1) Pole Cable Clip	
					
S-A (x4) Bushing	S-B (x2) M8x60mm Screw	S-C (x4) M8 Washer	S-D (x2) M8 Nut	S-F (x3) M6x16mm Screw	
					
T-A (x1) 4mm Allen Wrench	T-B (x1) 5mm Allen Wrench	T-C (x1) 6mm Allen Wrench	T-D (x1) 8mm Allen Wrench	T-E (x1) 13mm Wrench	T-F (x1) 19mm Wrench
					
M-A (x8) M4X12mm Screw	M-B (x8) M5x12mm Screw	M-C (x8) M5 Washer			

TOOLS NEEDED



NOTE: SOME HARDWARE INCLUDED MAY NOT BE USED

DO NOT EXCEED WEIGHT CAPACITY.

Failure to do so may result in serious injury.



ASSEMBLY STEPS

STEP 1

Insert Pole Cap (C) to top of Pole (B).



STEP 2

OPTION A: Clamp Installation

Attach Pole (B) to Clamp (D) using M6x16mm Screw (S-F). Tighten using 4mm Allen Wrench (T-A). Stick Soft Pads (G) to the underside of the Clamp (D). Attach Clamp (D) to desktop.

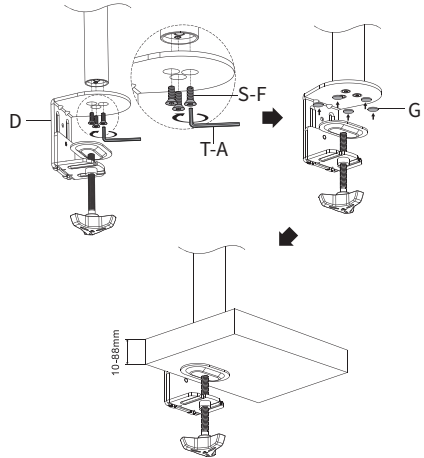

OPTION B: Grommet Base Installation

For grommet hole mounting, disassemble Clamp (D) using 4mm Allen Wrench (T-A). Remove the screw and plate from the clamp bolt, then remove the clamp bolt. Stick Soft Pads (G) to the bottom of the Grommet Plate (F). Slide Support Plate (H) onto the clamp bolt and insert bolt through the grommet hole and Grommet Plate (F), then thread into Pole (B).

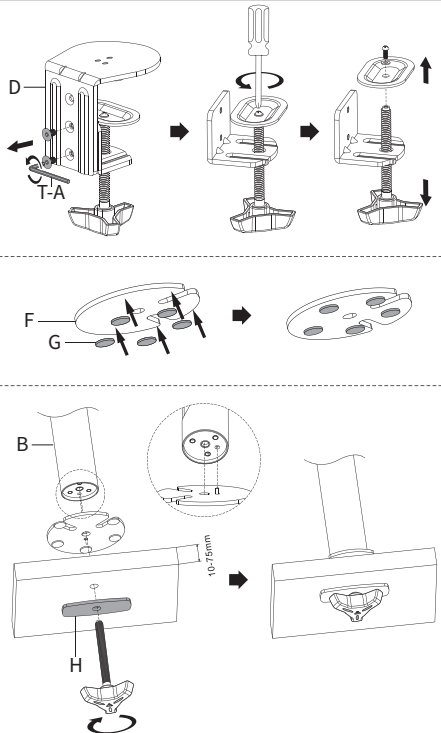

STEP 3

Place Bushings (**S-A**) into holes at the ends of the Arms (**A**). Install VESA Brackets (**E**) onto Arm (**A**) with M8x60mm Screws (**S-B**) and M8 Washers (**S-C**) and M8 Nuts (**S-D**), and tighten with 5mm Allen Wrench (**T-B**) and 13mm Wrench (**T-E**). Do not overtighten.

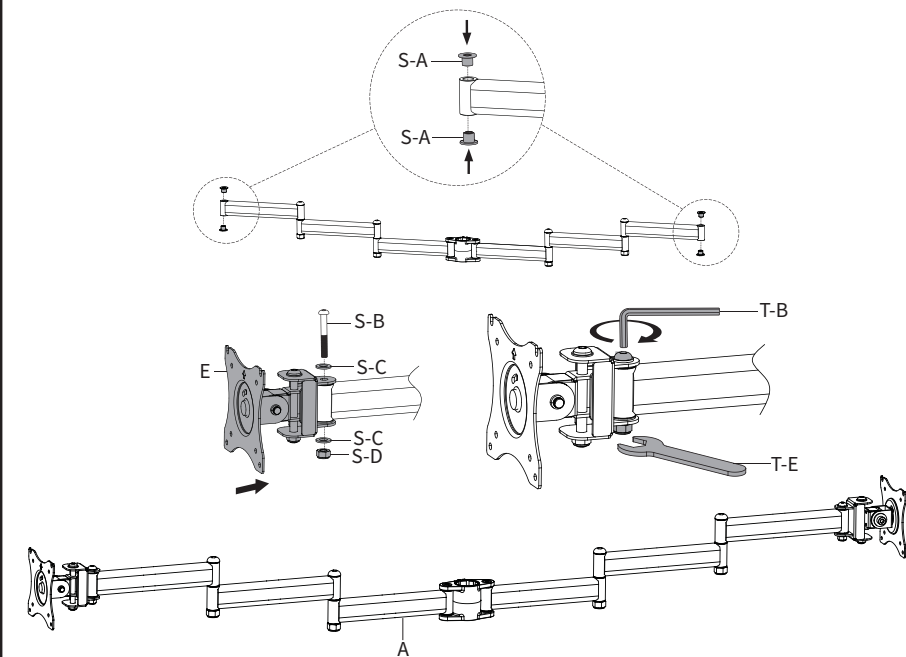

STEP 3

Slide Pole Cable Clip (**J**) and Arm (**A**) over the top of Pole (**B**) and tighten using the 5mm Allen Wrench (**T-B**).

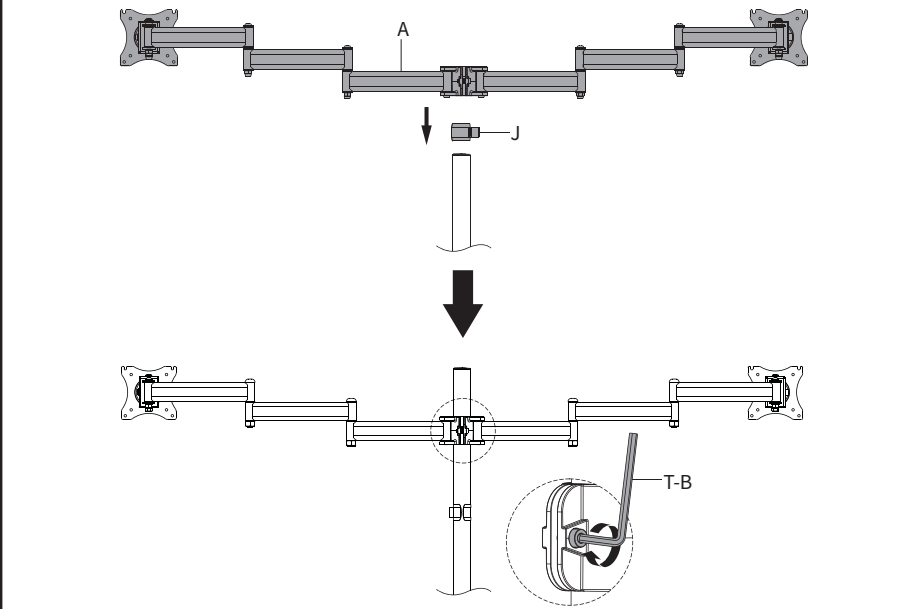

STEP 5

Attach Arm Cable Clips (**I**) to Arm (**A**) as shown.

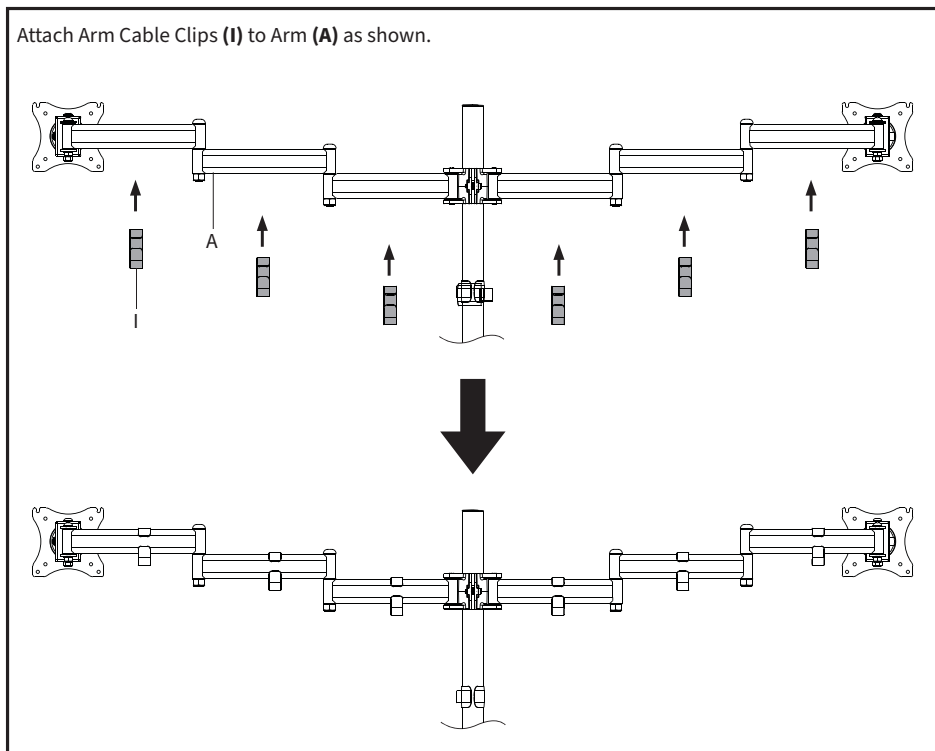

STEP 6

Install Screws (**M-A or M-B**) and M5 Washers (**M-C**) to the top mounting holes of your monitor, making sure to leave 3mm of threads exposed. Align Screws (**M-A or M-B**) in monitors over slots in the VESA plates.



NOTE : Tighten the tilt support bolt when monitor is being attached to prevent tipping.

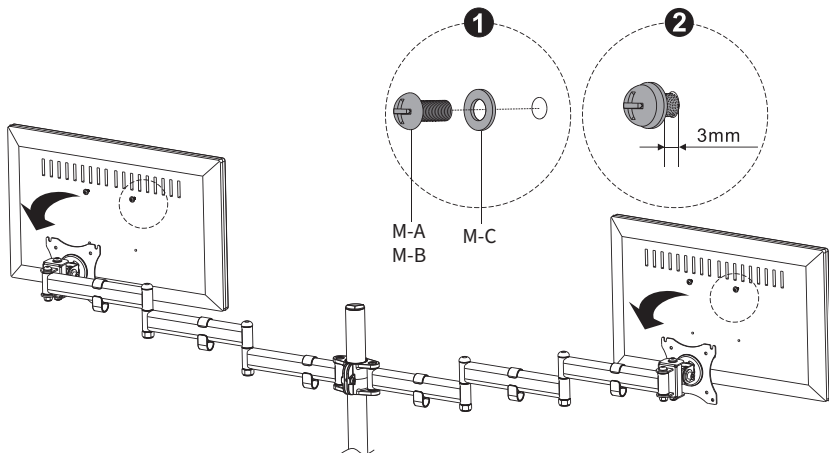

STEP 6 (Continued)

Secure using two more Screws (**M-A or M-B**) and M5 Washers (**M-C**) in the bottom two holes of each monitor. Tighten all four screws using a Phillips screwdriver.

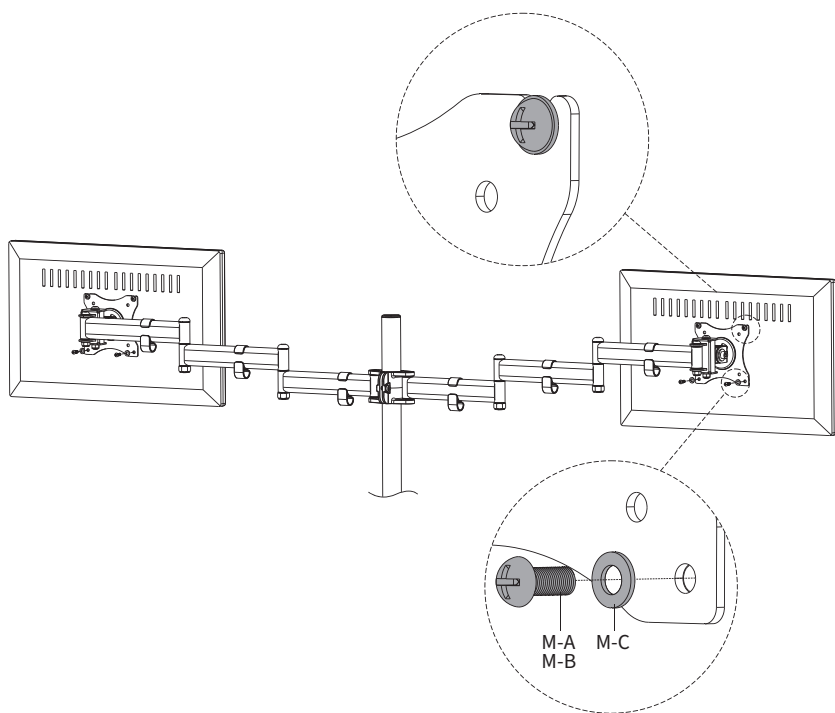

STEP 7

Adjust tilt support by loosening the screw on VESA Brackets (**E**) using 6mm Allen Wrench (**T-C**).

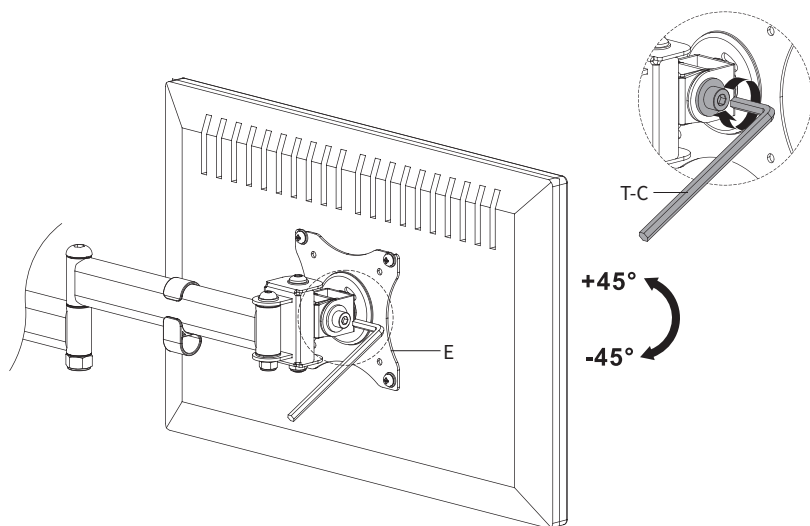

STEP 8

Store Allen Wrenches (**T-B**, **T-C**) in Pole Cable Clip (**J**) for future use.

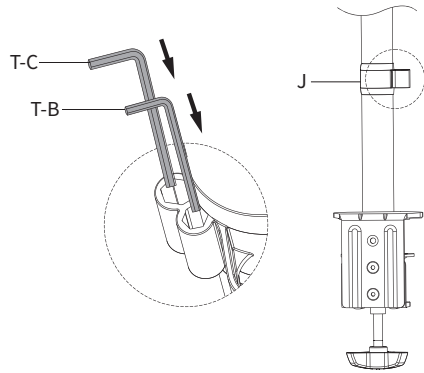

STEP 9

Tighten the joints in Arm (**A**) using 8mm Allen Wrench (**T-D**) with 19mm Wrench (**T-F**) and 5mm Allen Wrench (**T-B**) with 13mm Wrench (**T-E**).

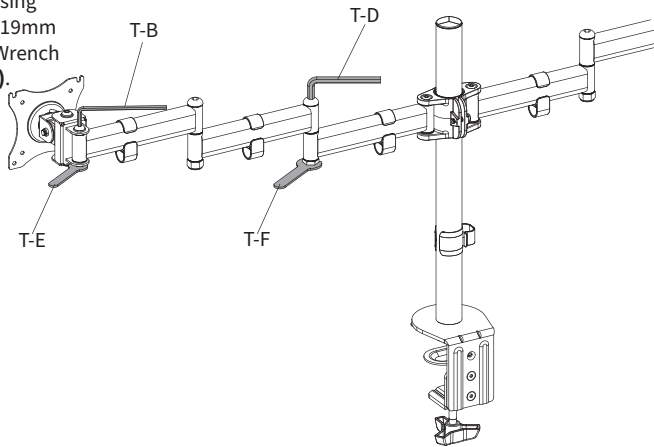

STEP 10

Adjust height of side monitors by turning the screw on top of each VESA Bracket (**E**) with the 5mm Allen Wrench (**T-B**) as shown.

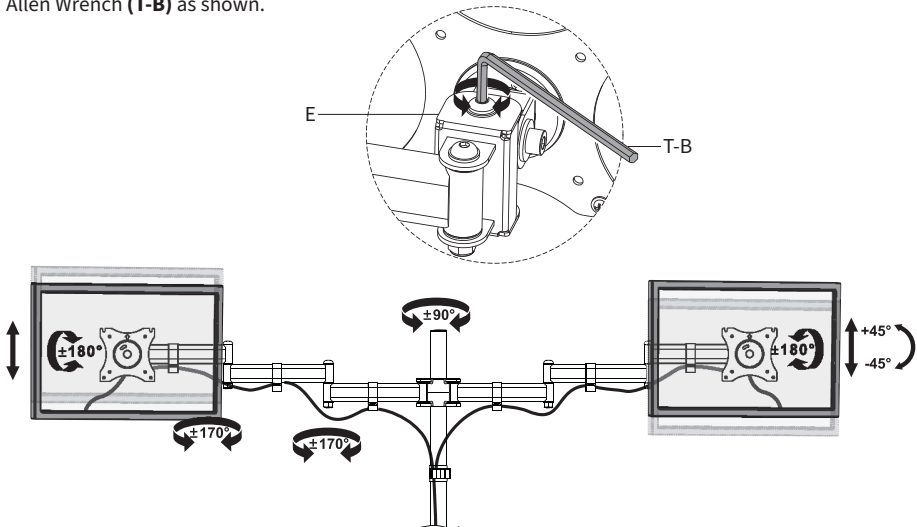



Open **Monday - Friday 7:00am - 7:00pm** CST,
our dedicated support team can offer immediate assistance with rapid response times. If any parts are received damaged or defective, please contact us. We are happy to replace parts to ensure you have a fully functioning product.



309-278-5303

AVG. RESOLUTION TIME (*within office hrs*): **5M 4S**



www.vivo-us.com
Chat live with an agent!

AVG. RESOLUTION TIME (*within office hrs*): **< 15 M**



help@vivo-us.com

AVG. RESPONSE TIME (*within office hrs*): **1HR 8M**

- 23% within < 15m
- 38% within < 30m
- 61% within < 1hr
- 83% within < 2hr
- 92% within < 3hr