

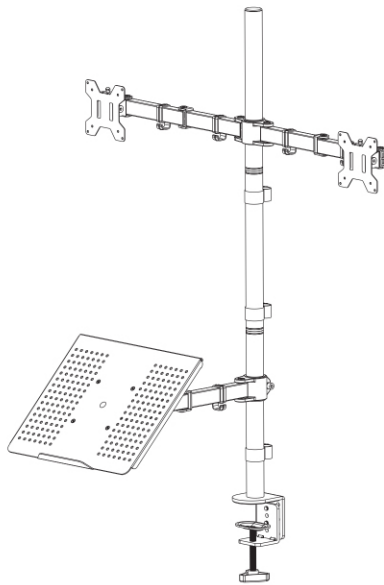

Dual Monitor Extra Tall Desk Mount with Laptop Holder

Instruction Manual



SKU: STAND-V012L



Scan the QR code with your mobile device or follow the link for helpful videos and specifications related to this product.

<https://vivo-us.com/products/stand-v012l>

GET IN TOUCH | Monday-Friday from 7:00am-7:00pm CST



help@vivo-us.com



www.vivo-us.com
Chat live with an agent!



309-278-5303

WARNING!

If you do not understand these directions, or if you have any doubts about the safety of the installation, please call a qualified technician. Check carefully to make sure there are no missing or defective parts. Improper installation may cause damage or serious injury. Do not use this product for any purpose that is not explicitly specified in this manual. Do not exceed weight capacity. We cannot be liable for damage or injury caused by improper mounting, incorrect assembly or inappropriate use.

TIPOVER WARNING

SERIOUS OR FATAL CRUSHING INJURIES CAN OCCUR FROM TIPOVER. TO HELP PREVENT TIPOVER:

- NEVER ALLOW CHILDREN TO CLIMB, STAND, HANG, OR PLAY ON ANY PART OF MONITOR OR STAND.
- USE TIPOVER RESTRAINT OR ANCHOR STAND TO WALL

USE OF TIPOVER RESTRAINTS MAY ONLY REDUCE, BUT NOT ELIMINATE RISK OF TIPOVER.

WARNING: CHOKING HAZARD

SMALL PARTS - NOT FOR CHILDREN UNDER 3 YEARS. ADULT SUPERVISION IS REQUIRED.

PACKAGE CONTENTS



A (x1)
Pole Set



B (x1)
Clamp



C (x1)
Clamp Brace



D1 (x1)
Swivel Arm



D2 (x1)
Swivel Arm



E (x3)
VESA Plate



F (x3)
M5x14



G (x2)
M8x12



H (x3)
Security Nut



I (x1)
M10 Washer



J (x1)
Spring Washer



K (x1)
Grommet Base Plate



L1 (x3)
Cable Clip



L2 (x6)
Cable Clip

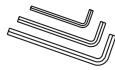

M (x1)
Allen Wrench Set



N (x12)
M4x12
Thumbscrew



O (x12)
M4x30



P (x12)
M4 Spacer

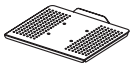

Q (x1)
Laptop Tray



R (x4)
M4x10 Bolt



S (x4)
M4 Nut



T1 (x1)
Clamp Pad



T2 (x1)
Grommet Pad

NOTE: SOME HARDWARE INCLUDED MAY NOT BE USED

TOOLS NEEDED



Phillips
Screwdriver



Drill



Wrench

DO NOT EXCEED WEIGHT CAPACITY.

Failure to do so may result in serious injury.

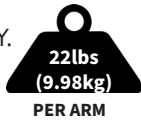

ASSEMBLY STEPS

PRE-ASSEMBLY

Thread the Pole Set **(A)** together as shown below.

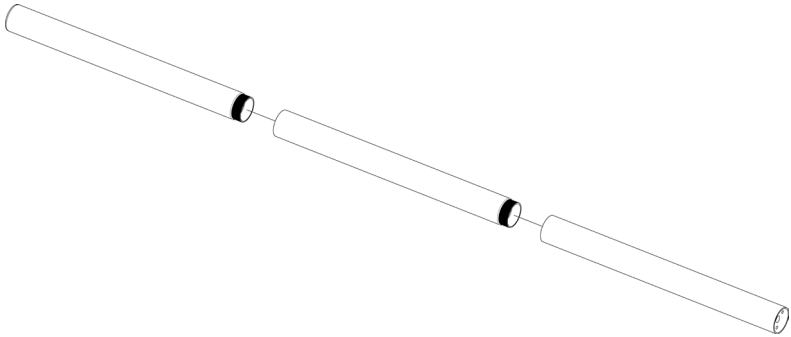

STEP 1

Option A: Desk Clamp Install

1. Install the clamp brace **(C)** to the pole **(A)** using x3 M5x14 bolts **(F)**. See Figure 1.
2. Attach soft pad **(T1)** to the clamp brace **(C)**, see Figure 2.
3. Install the clamp **(B)** to the pole assembly according to the thickness of the desktop. The thickness can be changed to 3 positions. Connect using x2 M8x12 bolts **(G)** and tighten using the Allen key **(M)**. Tighten the clamp to the desktop using the plastic knob. See Figure 3.

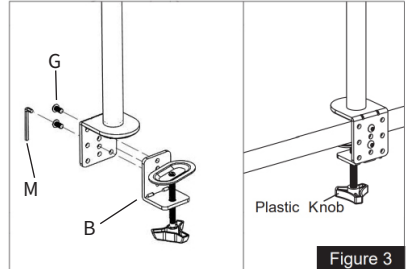
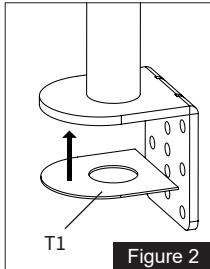
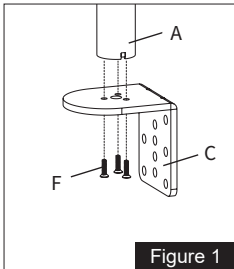

STEP 1 (Continued)

Option B: Grommet Install

1. If desk does not have an existing grommet hole, drill a 3/8" (10mm) diameter hole at the desired position through the mounting surface.
2. Completely disassemble clamp **(B)** into individual parts. Set knob **(B1)** and clamp plate **(B2)** aside for later use. The L bracket, bolt, washer and bushing will not be used.
3. Install grommet base plate **(K)** to the pole **(A)** using x3 M5x14 bolts **(F)**. See Figure 4.
4. Attach soft pad **(T2)** to the grommet base plate **(K)**, see Figure 5.
5. Position pole **(A)** on the mounting surface and secure using the clamp plate **(B2)**, spring washer **(J)**, M10 washer **(I)** and knob **(B1)**. See Figure 6.

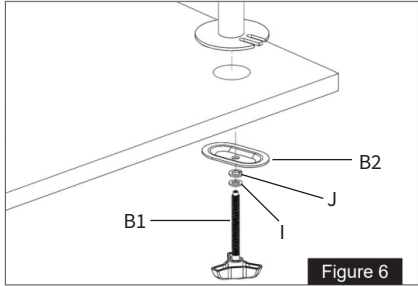
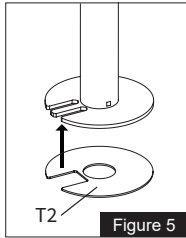
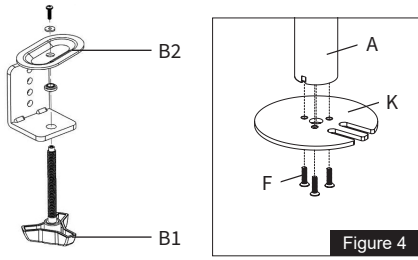

STEP 2

Install Swivel Arms **(D1, D2)** to the Pole **(A)**. Fasten the bolt on each arm with the large Allen wrench **(M)**. Attach the Wire Clips **(L1, L2)** to the pole **(A)** and Swivel Arms **(D)**.

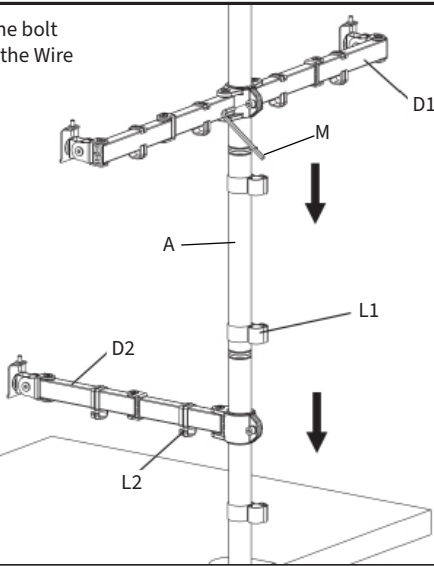

STEP 3

FOR LAPTOP

Attach VESA plate (E) to laptop tray (Q) using bolts (R) and M4 nuts (S).

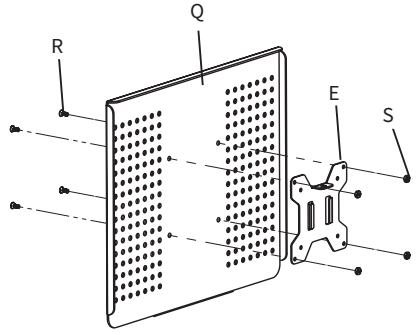

FOR FLAT BACK MONITOR

Attach VESA plate (E) to the monitor using M4x12 thumb screws (N).

NOTE: Hand tighten screws to avoid over tightening.

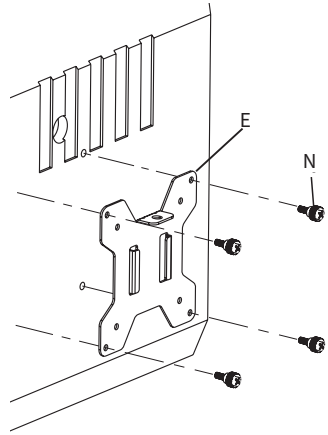

FOR CURVED BACK MONITOR

Attach VESA plate (E) to the monitor using bolts (O) and spacers (P).

NOTE: Gently tighten with a screwdriver.

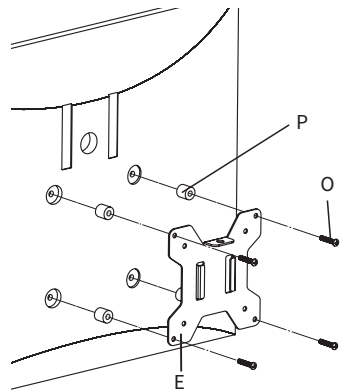

STEP 4

Slide the monitor onto the head of Swivel Arm **(D)** as shown in the diagram. Install the security Nut **(H)**. Make sure the security nut is installed before you rotate the monitor. Repeat for the laptop tray **(Q)**.

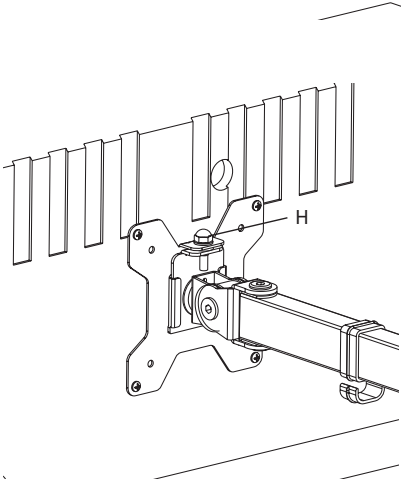
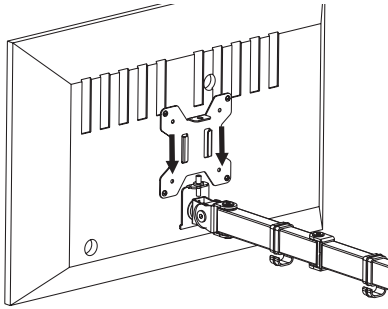

STEP 5

If needed, tighten the tilt joint bolt with the medium Allen wrench (**M**) to fix the tilt angle. Use the medium Allen wrench (**M**) to adjust the swivel joints as needed.

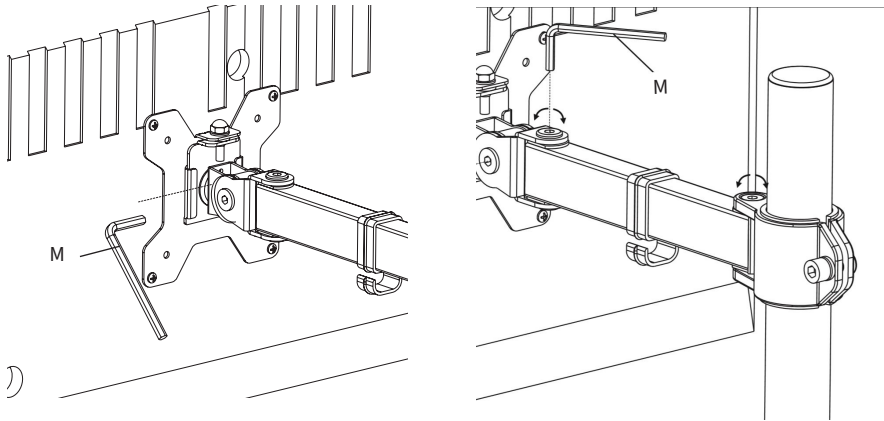

To level the monitors, remove the nut (**H**) and turn the bolt with the Allen key (**M**) to raise or lower the monitor. Replace nut (**H**) after the adjustment

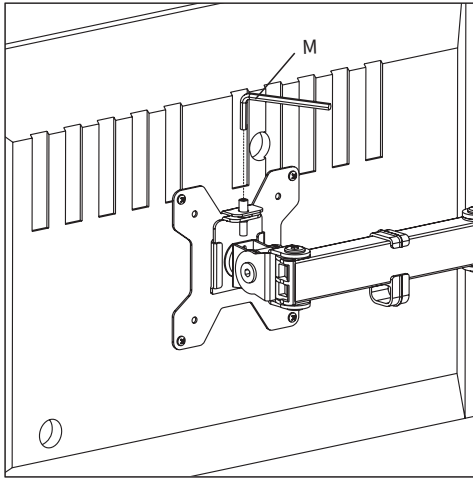

STEP 6

Manage cables using the wire clips (**L1, L2**). Store tools in the wire clips (**L1**).

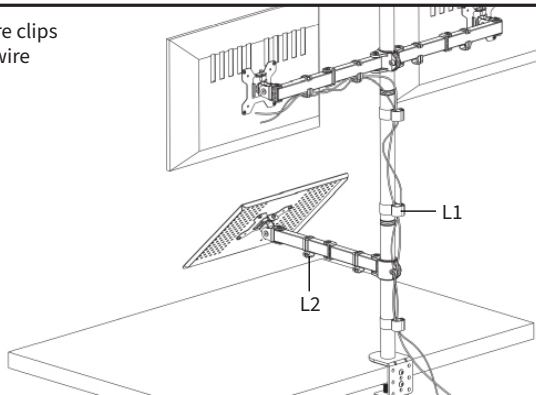



Open **Monday - Friday 7:00am - 7:00pm** CST,
our dedicated support team can offer immediate assistance with rapid response times. If any parts are received damaged or defective, please contact us. We are happy to replace parts to ensure you have a fully functioning product.

 help@vivo-us.com

AVG. RESPONSE TIME (*within office hrs*): **1HR 8M**

- 23% within < 15m
- 38% within < 30m
- 61% within < 1hr
- 83% within < 2hr
- 92% within < 3hr

 www.vivo-us.com
Chat live with an agent!

AVG. RESOLUTION TIME (*within office hrs*): **< 15 M**

 309-278-5303

AVG. RESOLUTION TIME (*within office hrs*): **5M 4S**