

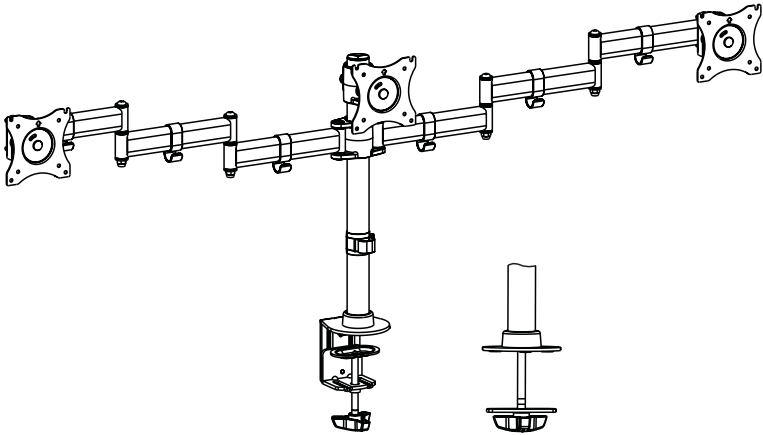

Triple Monitor Desk Mount

Instruction Manual



SKU: STAND-V003M



Scan the QR code with your mobile device or follow the link for helpful videos and specifications related to this product.

<https://vivo-us.com/products/stand-v003m>

GET IN TOUCH | Monday-Friday from 7:00am-7:00pm CST



help@vivo-us.com



www.vivo-us.com
Chat live with an agent!



309-278-5303

WARNING!

If you do not understand these directions, or if you have any doubts about the safety of the installation, please call a qualified technician. Check carefully to make sure there are no missing or defective parts. Improper installation may cause damage or serious injury. Do not use this product for any purpose that is not explicitly specified in this manual. Do not exceed weight capacity. We cannot be liable for damage or injury caused by improper mounting, incorrect assembly or inappropriate use.

TIPOVER WARNING

SERIOUS OR FATAL CRUSHING INJURIES CAN OCCUR FROM TIPOVER. TO HELP PREVENT TIPOVER:

- NEVER ALLOW CHILDREN TO CLIMB, STAND, HANG, OR PLAY ON ANY PART OF MONITOR OR STAND.
- USE TIPOVER RESTRAINT OR ANCHOR STAND TO WALL

USE OF TIPOVER RESTRAINTS MAY ONLY REDUCE, BUT NOT ELIMINATE RISK OF TIPOVER.

WARNING: CHOKING HAZARD

SMALL PARTS - NOT FOR CHILDREN UNDER 3 YEARS. ADULT SUPERVISION IS REQUIRED.

PACKAGE CONTENTS

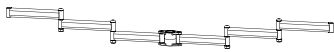

A (x1)
Arm

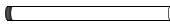

B (x1)
Pole



C (x2)
Side VESA Bracket



D (x1)
Center VESA Bracket

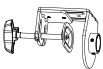

E (x1)
Clamp



F (x1)
Grommet Base



G (x6)
Cable Clip



H (x1)
Cable Clip



I (x1)
Pole Cover



J (x5)
Rubber Pad



K (x1)
Support Plate



L (x4)
Bushing



M (x2)
M8x60



N (x4)
D8 Washer



O (x2)
M8 Nut



P (x1)
3mm Allen Wrench



Q (x1)
5mm Allen Wrench



R (x1)
6mm Allen Wrench



S (x1)
Wrench



M-A (x12)
M4x12



M-B (x12)
M5x12



M-C (x12)
D5 Washer

NOTE: SOME HARDWARE INCLUDED MAY NOT BE USED

TOOLS NEEDED



DO NOT EXCEED WEIGHT CAPACITY.
Failure to do so may result in serious injury.



ASSEMBLY STEPS

STEP 1

OPTION A: Clamp Installation

Stick soft pads (J) to bottom of clamp base (E). Slide cable management clip (H) and base cover (I) on to bottom of pole (B). Thread pole (B) into clamp base (E), first loosening grub screws in the base if needed. Tighten grub screws in clamp base (E) using 3mm Allen wrench (P). Secure clamp (E) to desktop as shown in diagram.

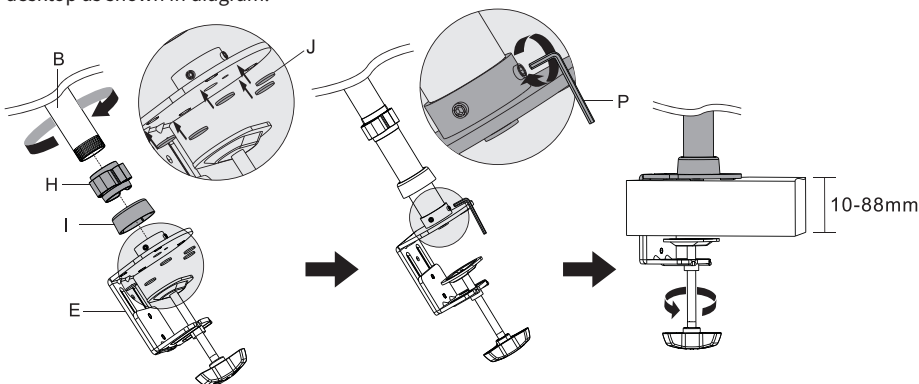

OPTION B: Grommet Base Installation

Remove screw from top of hand bolt in clamp (E), then remove hand bolt. Stick soft pads (J) to bottom of grommet base (F). Slide cable management clip (H) and base cover (I) on to bottom pole (B). Thread bottom pole (B) into grommet base (F), first loosening grub screws in the base if needed. Tighten grub screws in grommet base (F) using 3mm Allen wrench (P). Slide support plate (K) over hand bolt and slide through grommet hole in bottom of desktop. Thread into bottom of pole (B). If no grommet hole is present, drill hole using 3/8" (10mm) drill bit.

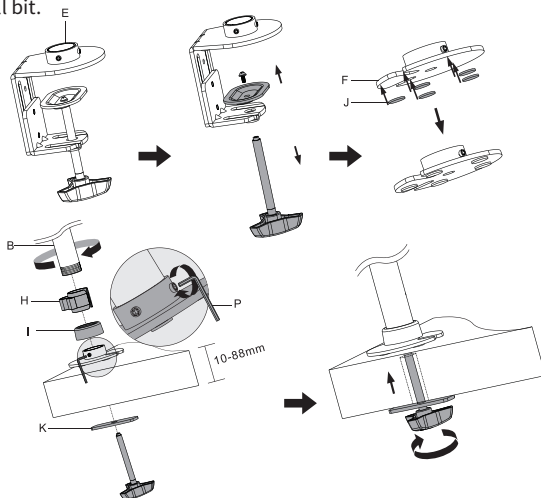
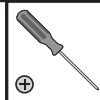

STEP 2

Place bushings (**L**) into holes at ends of arms (**A**). Place side VESA brackets (**C**) onto arms with M8x60 bolts. Secure with D8 washers (**N**) and M8 nuts (**O**), and tighten with 5mm Allen wrench (**Q**) and wrench (**S**). Do not overtighten.

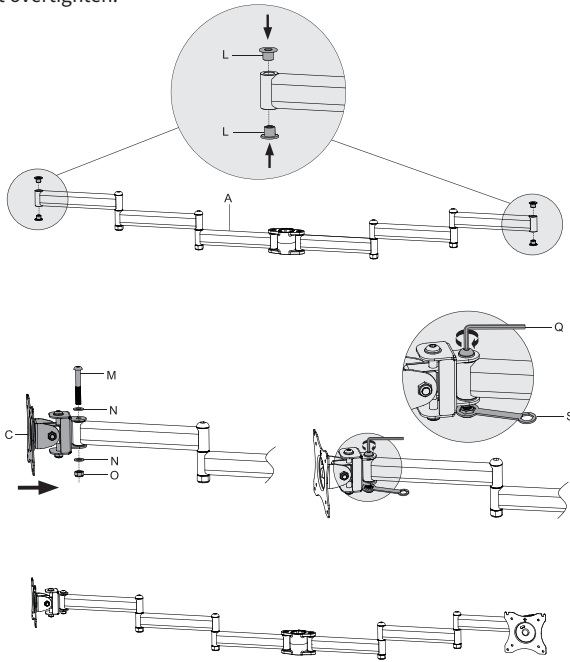

STEP 3

Slide arm (**A**) and center VESA bracket (**D**) over top of pole and tighten using 5mm Allen wrench (**Q**).

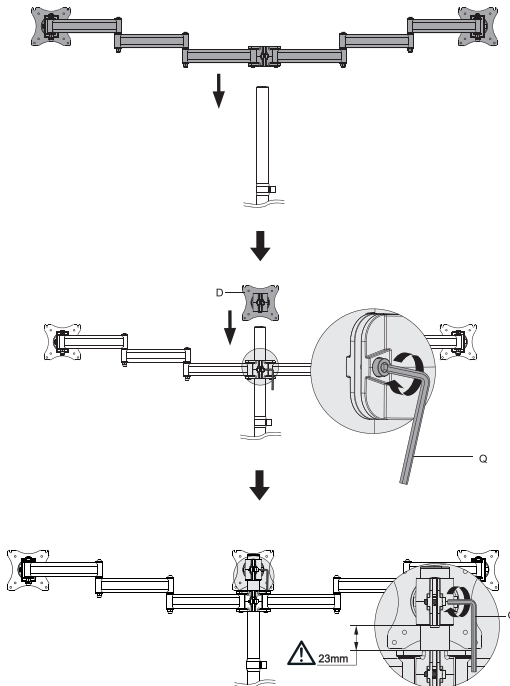

STEP 4

Attach cable management clips (**G**) to arms (**A**) as shown.

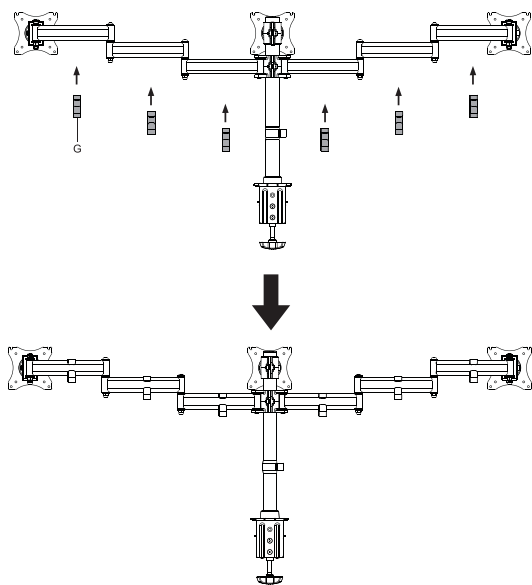

STEP 5

Attach two bolts (**M-A or M-B**) and washers (**M-C**) to top mounting holes of monitor, making sure to leave 3mm of threads exposed. Align bolts (**M-A or M-B**) in monitor over slots in VESA plates. Secure using two more bolts (**M-A or M-B**) and washers (**M-C**) in the bottom two holes of each monitor. Tighten all four bolts using Phillips screwdriver.

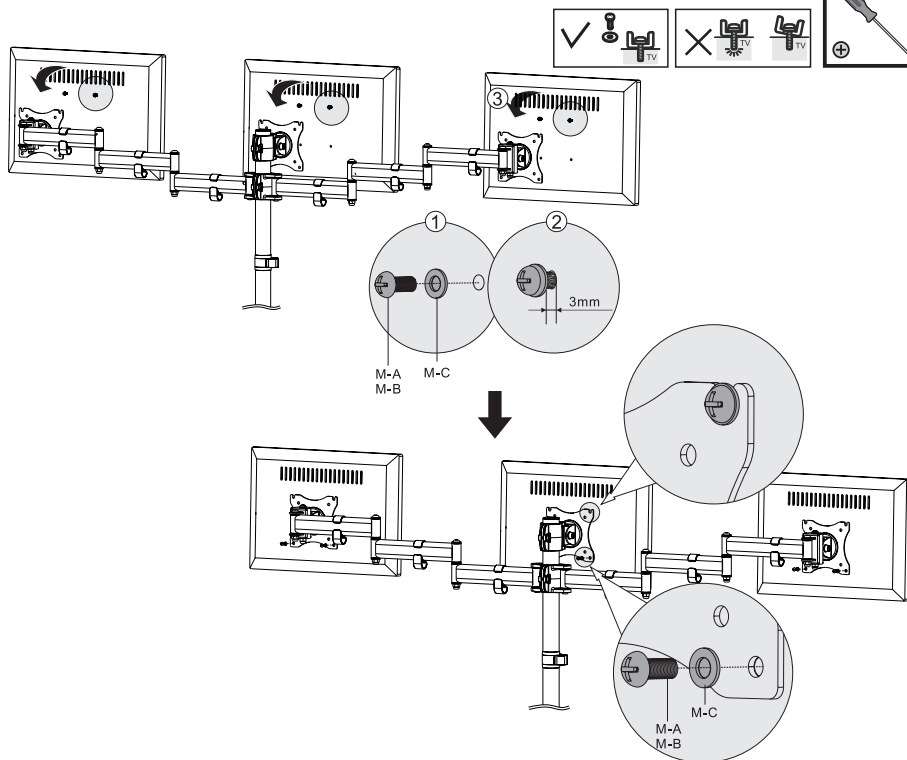

STEP 6

Adjust tension in monitor bracket with 6mm allen wrench (**R**).

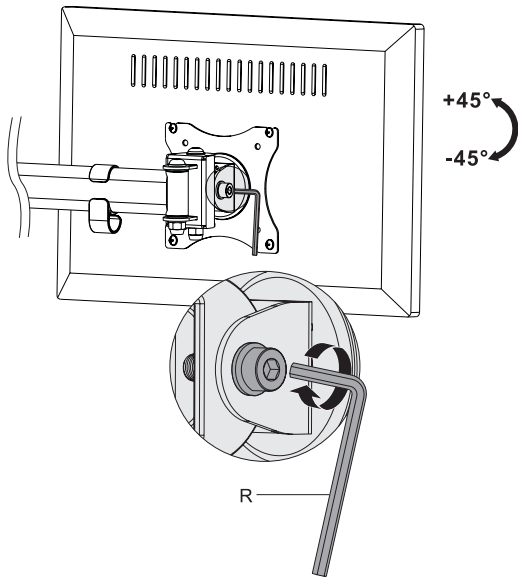

STEP 7

Store Allen wrenches (**R**, **Q**) in cable management clip (**G**) for future use.

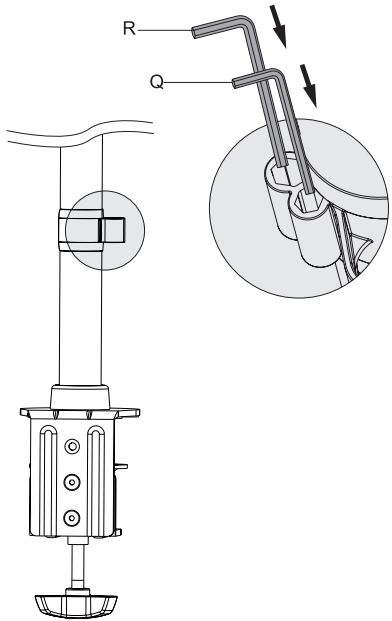

STEP 8

Adjust height of side monitors by turning bolt on top of each bracket with 5mm Allen wrench (**Q**) as shown.

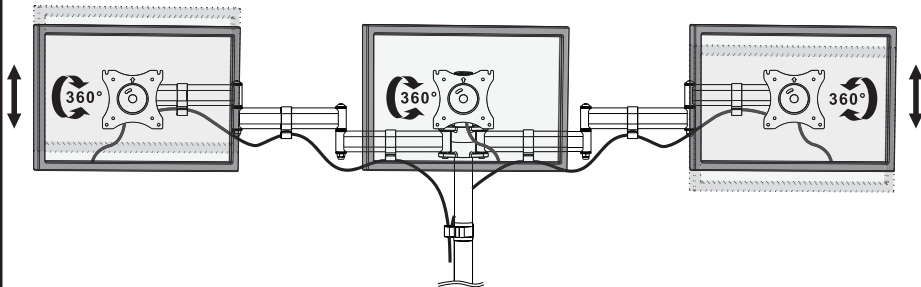
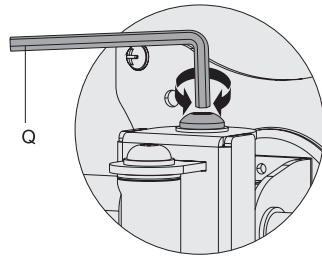

 Love your new VIVO setup and want to share?
Tag us in your photo! [@vivo_us](#)

LAST UPDATED: 05/18/2020



Open **Monday - Friday 7:00am - 7:00pm** CST,

our dedicated support team can offer immediate assistance with rapid response times. If any parts are received damaged or defective, please contact us. We are happy to replace parts to ensure you have a fully functioning product.

 help@vivo-us.com

AVG. RESPONSE TIME (*within office hrs*): **1HR 8M**

- 23% within < 15m
- 38% within < 30m
- 61% within < 1hr
- 83% within < 2hr
- 92% within < 3hr

 www.vivo-us.com
Chat live with an agent!

AVG. RESOLUTION TIME (*within office hrs*): **< 15 M**

 309-278-5303

AVG. RESOLUTION TIME (*within office hrs*): **5M 4S**

FOR MORE VIVO PRODUCTS, CHECK OUT OUR WEBSITE AT: www.vivo-us.com