

Triple Monitor Desk Stand Instruction Manual

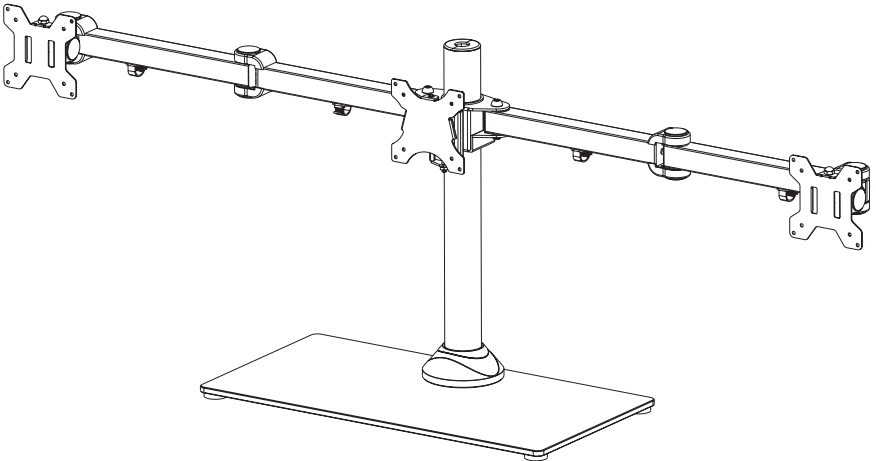

SKU: STAND-V003FG



Scan the QR code with your mobile device or follow the link for helpful videos and specifications related to this product.

<https://vivo-us.com/products/stand-v003fg>

GET IN TOUCH | Monday-Friday from 7:00am-7:00pm CST



help@vivo-us.com



www.vivo-us.com
Chat live with an agent!



309-278-5303

⚠ WARNING!

If you do not understand these directions, or if you have any doubts about the safety of the installation, please call a qualified technician. Check carefully to make sure there are no missing or defective parts. Improper installation may cause damage or serious injury. Do not use this product for any purpose that is not explicitly specified in this manual. Do not exceed weight capacity. We cannot be liable for damage or injury caused by improper mounting, incorrect assembly or inappropriate use.

⚠ TIPOVER WARNING











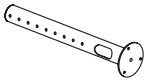
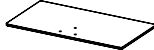
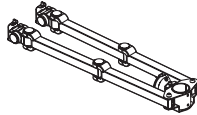









SERIOUS OR FATAL CRUSHING INJURIES CAN OCCUR FROM TIPOVER. TO HELP PREVENT TIPOVER:

- TO PREVENT TIPPING, PLEASE BE CAREFUL NOT TO EXTEND THE ARMS TOO FAR FORWARD OR BACKWARD.
 - NEVER ALLOW CHILDREN TO CLIMB, STAND, HANG, OR PLAY ON ANY PART OF MONITOR OR STAND.
 - USE TIPOVER RESTRAINT OR ANCHOR STAND TO WALL.
- USE OF TIPOVER RESTRAINTS MAY ONLY REDUCE, BUT NOT ELIMINATE RISK OF TIPOVER.

⚠ WARNING: CHOKING HAZARD

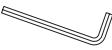
SMALL PARTS - NOT FOR CHILDREN UNDER 3 YEARS. ADULT SUPERVISION IS REQUIRED.

PACKAGE CONTENTS

				
A (x1) Pole	B (x1) Glass Base	C (x1) Arm	D (x1) Decorative Cover	E (x1) Soft Pad
				
F (x4) Rubber Feet	G (x2) Side VESA Plate	H (x1) Center VESA Plate	I (x2) Spare Plastic Cover	
				
S-A (x3) M8x8mm Screw	S-B (x3) M8 Washer	S-C (x2) M8x10mm Screw	S-D (x3) M6x10mm Screw	S-E (x1) M4x6mm Screw
				
S-F (x2) Security Nut	M-A (x12) M4x12mm Screw	M-B (x12) M4x30mm Screw	M-C (x12) M4 Spacer	T-A (x1) 3mm Allen Wrench
				
T-B (x1) 4mm Allen Wrench	T-C (x1) 5mm Allen Wrench	T-D (x1) 6mm Allen Wrench	T-E (x1) Wrench	

NOTE: SOME HARDWARE INCLUDED MAY NOT BE USED

TOOLS NEEDED



DO NOT EXCEED WEIGHT CAPACITY.

Failure to do so may result in serious injury.



ASSEMBLY STEPS

STEP 1

Attach Rubber Feet (**F**) to the underside of the Glass Base (**B**). Attach Soft Pad (**E**) to the Pole (**A**). Use a screwdriver to poke holes for screws through the Pad.

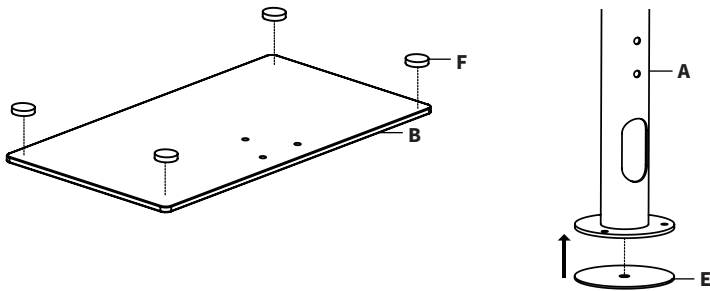

Install Pole (**A**) to Glass Base (**B**) using M6x10mm Screws (**S-D**), M8x8mm Screws (**S-A**), M8 Washers (**S-B**), 4mm Allen Wrench (**T-B**), and a Phillips screwdriver. Slide Decorative Cover (**D**) over the Pole.

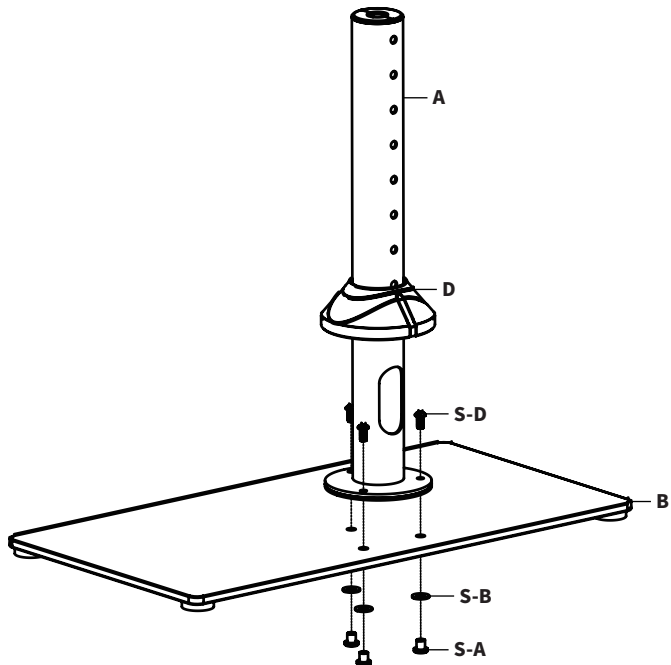

STEP 2

Install Arm (C) to the Pole (A). Secure using M8x10mm Screws (S-C) and 5mm Allen Wrench (T-C).

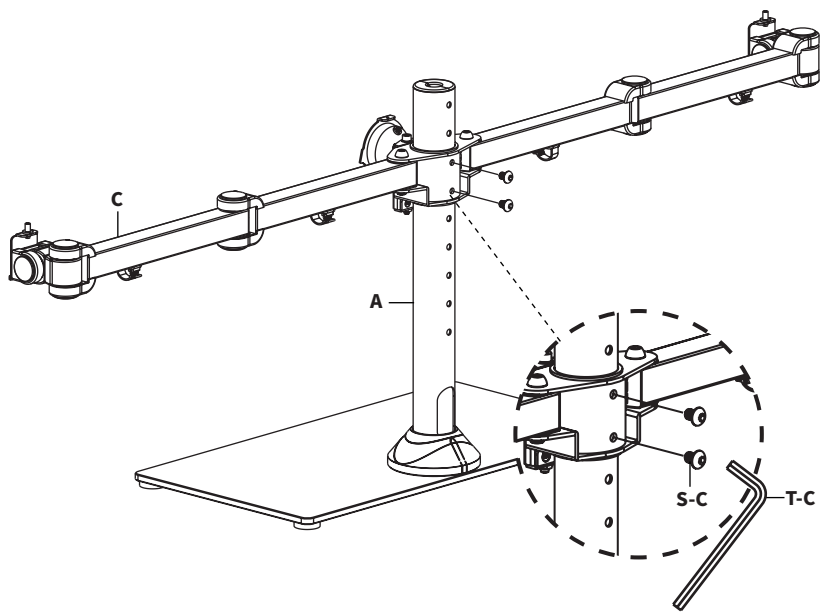

STEP 3a - Flat Back Monitors

OPTION A: Flat Back Monitor

Attach the Center VESA Plates (K) to the monitors you intend to mount in the center of the mount. Attach Side VESA Plates (J) to remaining monitors. Secure using M4x12mm Screws (M-A).

NOTE: Hand tighten screws to avoid stripping the plastic screw heads.

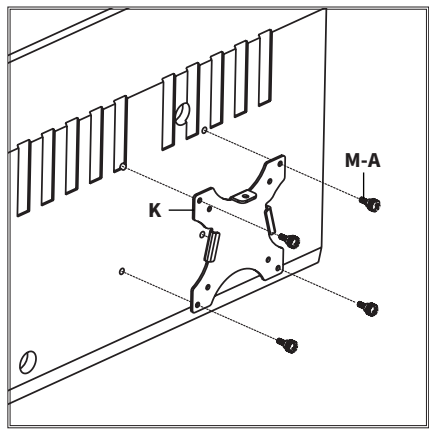

Center VESA Plate (K) Installation

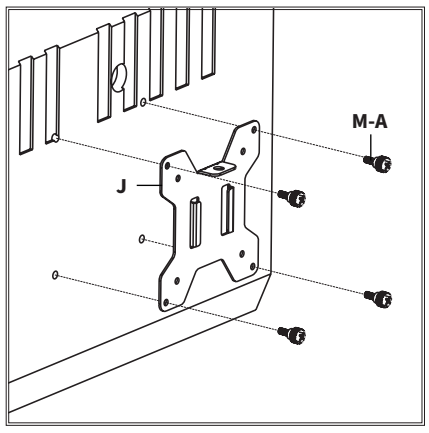

Side VESA Plate (J) Installation

STEP 3b - Curved/Recessed Back Monitors

Attach the Center VESA Plates (**K**) to the monitors you intend to mount in the center of the mount. Attach Side VESA Plates (**J**) to remaining monitors. Secure using M4 Spacers (**M-C**), M4x30mm Screws (**M-B**) and a Phillips screwdriver.

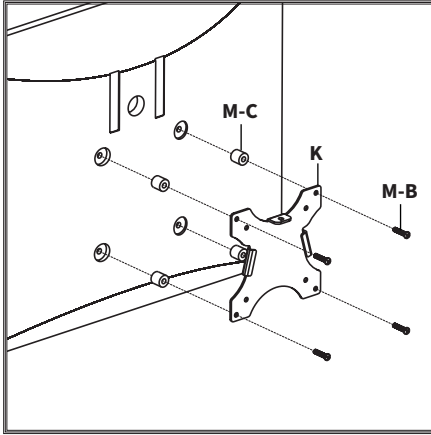

Center VESA Plate (K) Installation

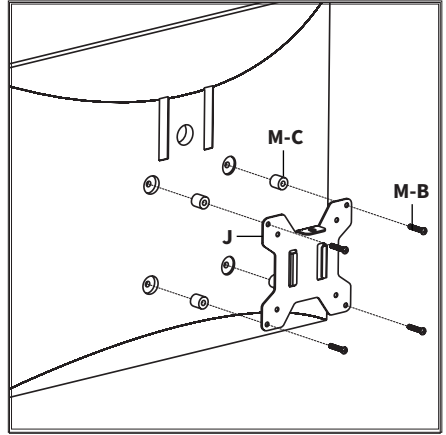

Side VESA Plate (J) Installation

STEP 4

Slide the center monitor onto the Center Head (**C1**) of Monitor Arm (**C**). Install the M4x6mm (**S-E**) to secure the monitor.

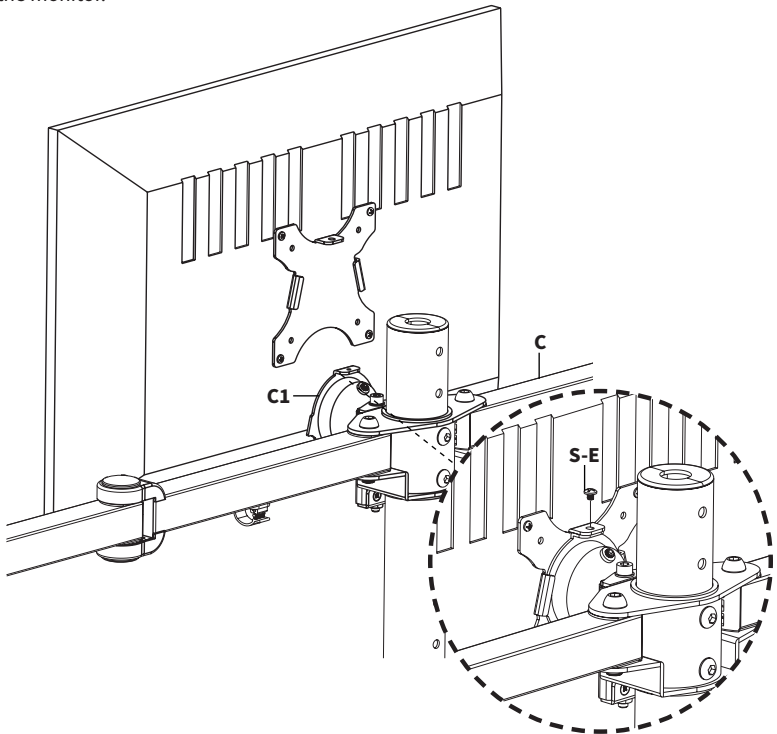

STEP 6

Slide the outer monitors onto Outer VESA Heads (**C2**). Secure with Security Nut (**S-F**).

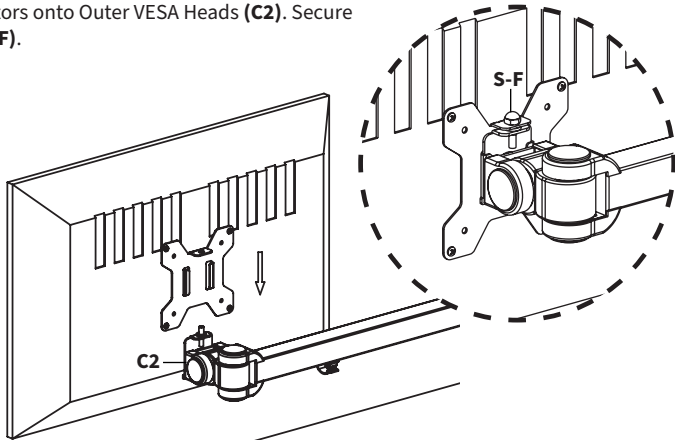

Adjust Monitor Tilt

Pry off Plastic Covers (**C3**) from the Outer VESA Heads (**C2**). The exposed nut on the side is used to adjust the tilt. Tighten the nut using Wrench (**T-E**) to adjust. Replace Plastic Covers (**C3**).

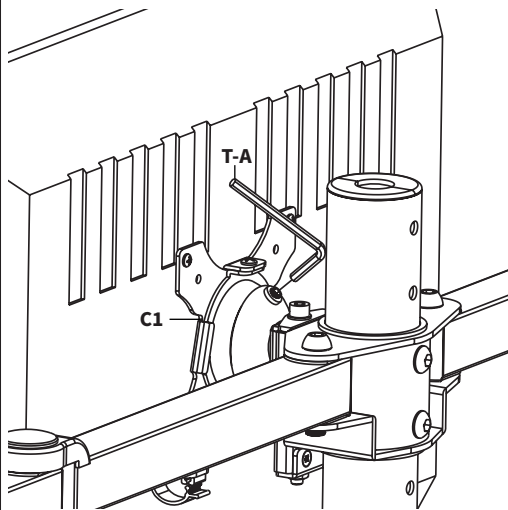
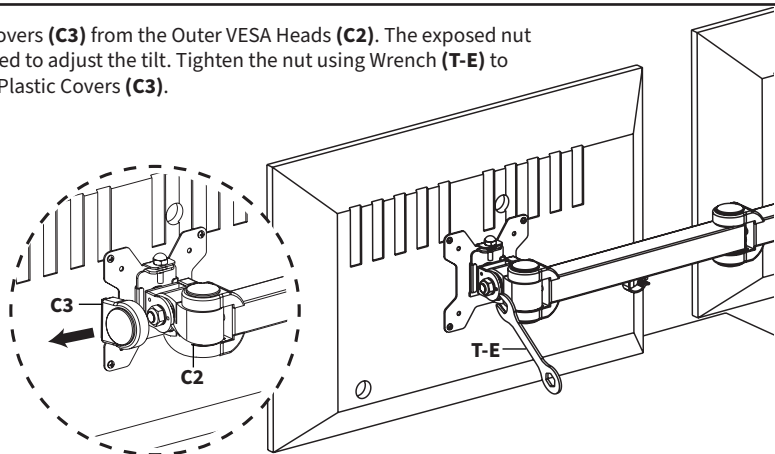

To adjust center monitor swivel or tilt, use 3mm Allen Wrench (**T-A**) to loosen center set screw on the Center Head (**C1**), as shown at left.

Adjust Monitor Height

To adjust center monitor height, turn the screw behind Center Head (**C1**) and Mount Bracket (**D**) using the 5mm Allen Wrench (**T-B**). To level the side monitors, remove the Cap Nut (**S-F**) and turn the inner bolt with the 3mm Allen Wrench (**T-A**) to raise or lower the monitor. Replace Nut after the adjustment.

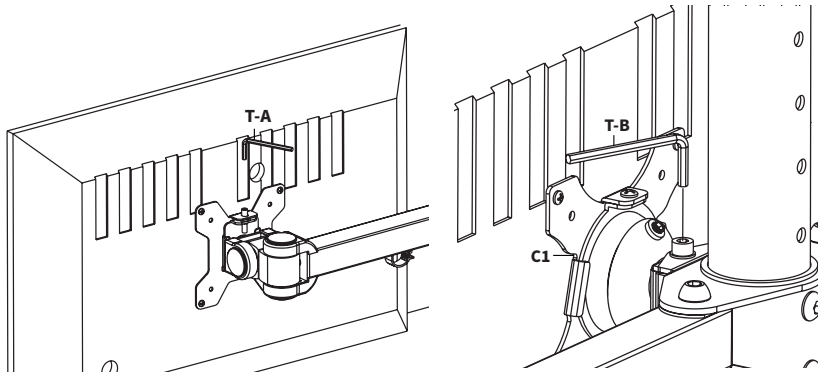

To adjust swivel joint tension, remove the Monitor Arm Cover and turn the bolt underneath with the 6mm Allen Wrench (**T-D**).

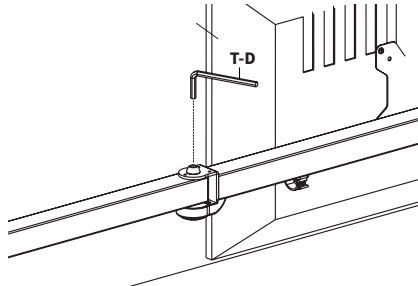

Cable Management

Manage cables using Wire Clips (**C4**) on Arm (**C**). Remove the split cap from the Pole (**A**) and feed cables through, pulling ends out from the opening in back. Replace the split cap when finished.

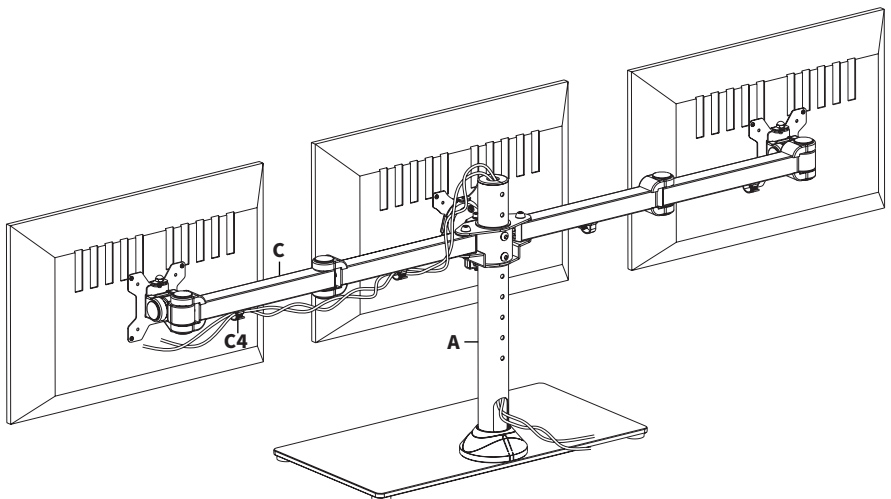



Love your new VIVO setup and want to share?
Tag us in your photo! [@vivo_us](#)

LAST UPDATED: 11/07/2023
REV2.1



Open **Monday - Friday 7:00am - 7:00pm** CST,
our dedicated support team can offer immediate assistance with rapid response times. If any parts are received damaged or defective, please contact us. We are happy to replace parts to ensure you have a fully functioning product.



309-278-5303

AVG. RESOLUTION TIME (*within office hrs*): **5M 4S**



www.vivo-us.com

Chat live with an agent!

AVG. RESOLUTION TIME (*within office hrs*): **< 15 M**



help@vivo-us.com

AVG. RESPONSE TIME (*within office hrs*): **1HR 8M**
- 23% within < 15m
- 38% within < 30m
- 61% within < 1hr
- 83% within < 2hr
- 92% within < 3hr

FOR MORE VIVO PRODUCTS, CHECK OUT OUR WEBSITE AT: www.vivo-us.com