

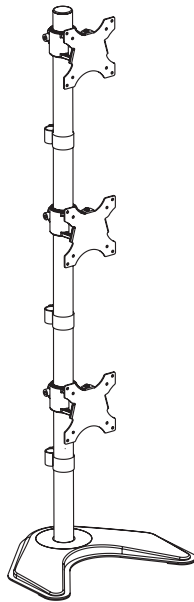

Triple Vertical Monitor Desk Stand

Instruction Manual



SKU: STAND-V003D



Scan the QR code with your mobile device or follow the link for helpful videos and specifications related to this product.

<https://vivo-us.com/products/stand-v003d>

GET IN TOUCH | Monday-Friday from 7:00am-7:00pm CST



help@vivo-us.com



www.vivo-us.com
Chat live with an agent!



309-278-5303

WARNING!

If you do not understand these directions, or if you have any doubts about the safety of the installation, please call a qualified technician. Check carefully to make sure there are no missing or defective parts. Improper installation may cause damage or serious injury. Do not use this product for any purpose that is not explicitly specified in this manual. Do not exceed weight capacity. We cannot be liable for damage or injury caused by improper mounting, incorrect assembly or inappropriate use.

TIPOVER WARNING

SERIOUS OR FATAL CRUSHING INJURIES CAN OCCUR FROM TIPOVER. TO HELP PREVENT TIPOVER:

- NEVER ALLOW CHILDREN TO CLIMB, STAND, HANG, OR PLAY ON ANY PART OF MONITOR OR STAND.
- USE TIPOVER RESTRAINT OR ANCHOR STAND TO WALL

USE OF TIPOVER RESTRAINTS MAY ONLY REDUCE, BUT NOT ELIMINATE RISK OF TIPOVER.

WARNING: CHOKING HAZARD

SMALL PARTS - NOT FOR CHILDREN UNDER 3 YEARS. ADULT SUPERVISION IS REQUIRED.

PACKAGE CONTENTS



A (x1)
Pole Set



B (x1)
Base



C (x3)
Arm



D (x3)
VESA Plate



E (x3)
M4x6



F (x3)
M5x14



G (x3)
Wire Clip

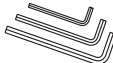

H (x1)
Allen Wrench
Set



I (x12)
M4x12
Thumbscrew



J (x12)
M4x30



K (x12)
M4 Spacer

NOTE: SOME HARDWARE INCLUDED MAY NOT BE USED

TOOLS NEEDED



DO NOT EXCEED WEIGHT CAPACITY.
Failure to do so may result in serious injury.



ASSEMBLY STEPS

STEP 1

Thread the Pole Set **(A)** together as shown below.

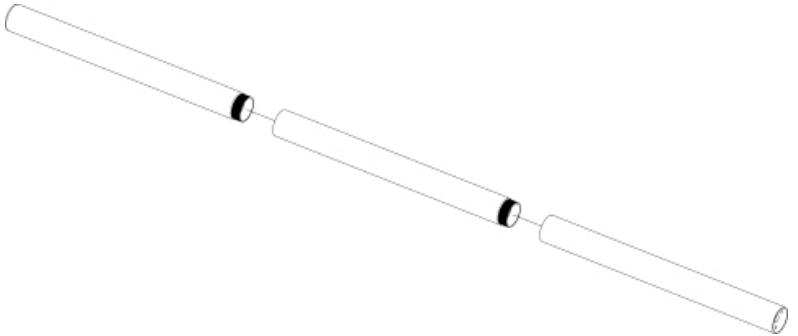

STEP 2

Install the Pole **(A)** to the Weighted Base **(B)** using M5x14 Bolts **(F)**, and tighten using the Allen Wrench **(H)**.

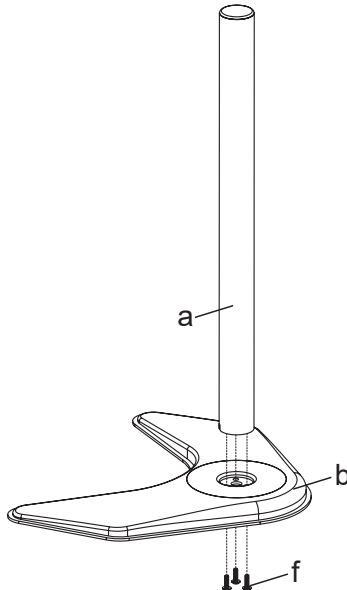

STEP 3

Install Monitor Arm (C) to the Pole (A). Fasten the bolt with supplied Allen Wrench (H). Attach the Wire Clip (G) to the Pole (A).

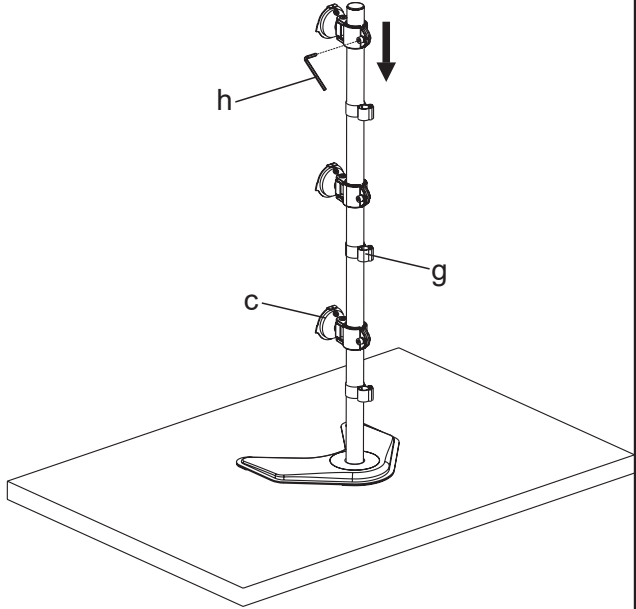

STEP 4

OPTION A: Flat Back Monitor

For monitors with flat backs attach VESA plate (D) using M4x12 Thumb Bolts (I).

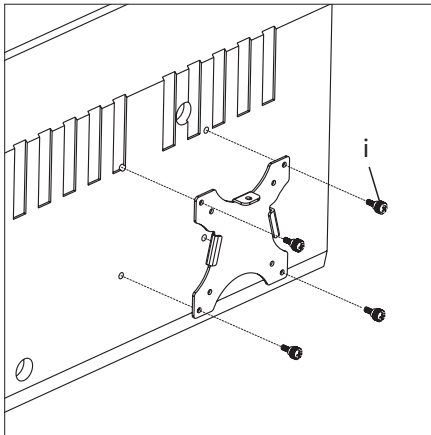

STEP 4 (Continued)

OPTION B: Curved Back Monitor

For monitors with curved or recessed backs attach VESA plate using M4x30 Bolts (J) and M4 Spacers (K).

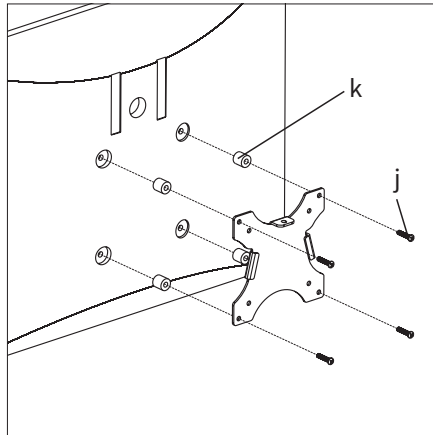

STEP 5

Slide the monitor onto the head of Monitor Arm (C) as shown in the diagram. Install the M4x6 Bolt (E). Make sure the bolt is installed before you rotate the monitor.

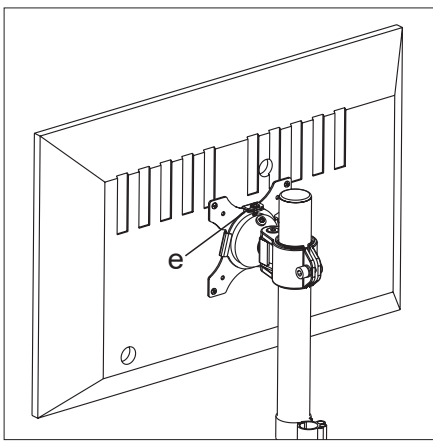
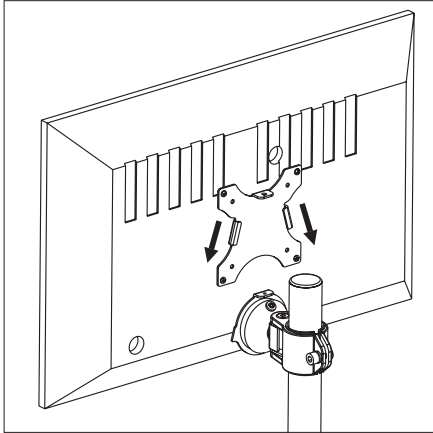

STEP 6

Fasten the grub screw in Monitor Arm to fix the tilting angle by provided Allen Wrench (**H**). Manage the wires as in the diagram.

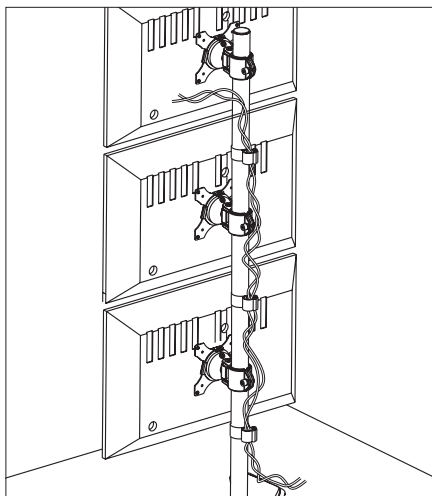
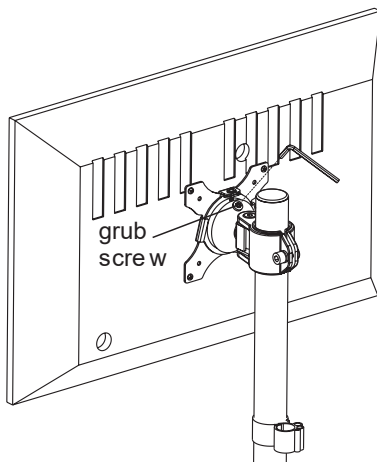



Open **Monday - Friday 7:00am - 7:00pm** CST,
our dedicated support team can offer immediate assistance with rapid response times. If any parts are received damaged or defective, please contact us. We are happy to replace parts to ensure you have a fully functioning product.

 help@vivo-us.com

AVG. RESPONSE TIME (*within office hrs*): **1HR 8M**

- 23% within < 15m
- 38% within < 30m
- 61% within < 1hr
- 83% within < 2hr
- 92% within < 3hr

 www.vivo-us.com
Chat live with an agent!

AVG. RESOLUTION TIME (*within office hrs*): **< 15 M**

 309-278-5303

AVG. RESOLUTION TIME (*within office hrs*): **5M 4S**