



Clamp-on Aluminum Monitor Riser

Instruction Manual



SKU: STAND-V000SC



Scan the QR code with your mobile device or follow the link for helpful videos and specifications related to this product.

<https://vivo-us.com/products/stand-v000s>

GET IN TOUCH | Monday-Friday from 7:00am-7:00pm CST



help@vivo-us.com



www.vivo-us.com
Chat live with an agent!



309-278-5303

WARNING!

If you do not understand these directions, or if you have any doubts about the safety of the installation, please call a qualified technician. Check carefully to make sure there are no missing or defective parts. Improper installation may cause damage or serious injury. Do not use this product for any purpose that is not explicitly specified in this manual. Do not exceed weight capacity. We cannot be liable for damage or injury caused by improper mounting, incorrect assembly or inappropriate use.

TIPOVER WARNING

SERIOUS OR FATAL CRUSHING INJURIES CAN OCCUR FROM TIPOVER. TO HELP PREVENT TIPOVER:

- NEVER ALLOW CHILDREN TO CLIMB, STAND, HANG, OR PLAY ON ANY PART OF MONITOR OR STAND.
- USE TIPOVER RESTRAINT OR ANCHOR STAND TO WALL

USE OF TIPOVER RESTRAINTS MAY ONLY REDUCE, BUT NOT ELIMINATE RISK OF TIPOVER.

WARNING: CHOKING HAZARD

SMALL PARTS - NOT FOR CHILDREN UNDER 3 YEARS. ADULT SUPERVISION IS REQUIRED.

PACKAGE CONTENTS

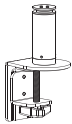

A (x1)
Clamp

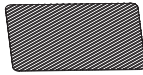

B (x1)
Padding



C (x1)
Platform



S-A (x4)
M5x10



S-B (x1)
Magnet



T-A (x1)
3mm Allen Wrench



T-B (x1)
4mm Allen Wrench

DO NOT EXCEED WEIGHT CAPACITY.

Failure to do so may result in serious injury.



ASSEMBLY STEPS

STEP 1

Clamp **(A)** comes preassembled to fit desktops with a thickness of 10-50mm. For desktops with a thickness between 40-85mm, Clamp **(A)** can be adjusted by removing screws in back of assembly using 4mm Allen Wrench **(T-B)** and reassembling using the bottom two holes.

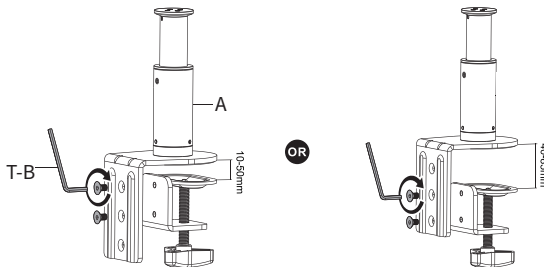

STEP 2

Secure Clamp **(A)** to desktop by tightening knob.

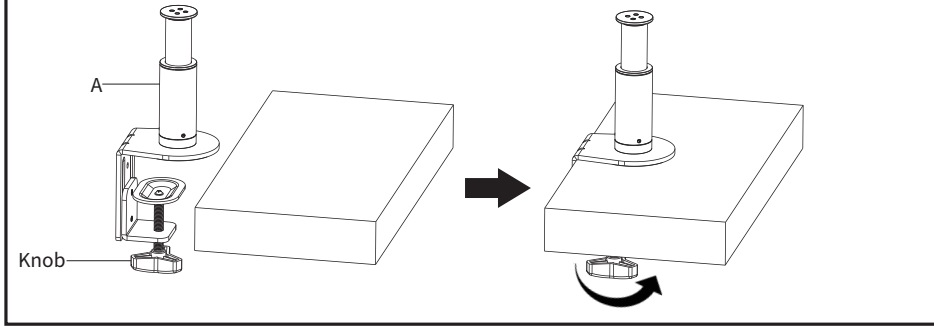

STEP 3

Attach Platform **(C)** to Clamp **(A)** using M5x10 Screws **(S-A)** and 3mm Allen Wrench **(T-A)**.

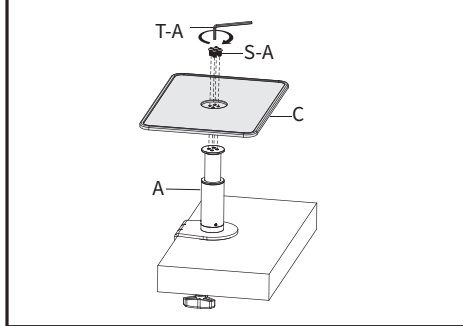

STEP 4

Remove adhesive backing from Padding **(B)**.

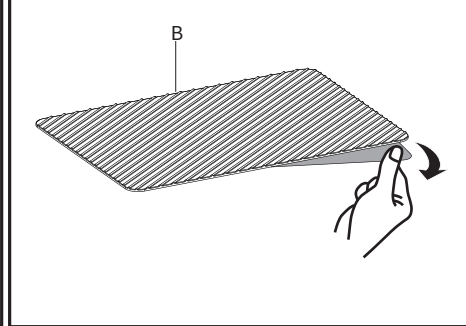

STEP 5

Place Padding **(B)** on top of Platform **(C)**, taking care to align correctly. Loosen set screw in center post of Clamp **(A)** using 3mm Allen Wrench **(T-A)** to adjust the height. Once you've reached the desired position, retighten the set screw to secure. Place Magnet **(S-B)** under Platform **(C)** to store Allen Wrenches **(T-A, T-B)** for future adjustments.

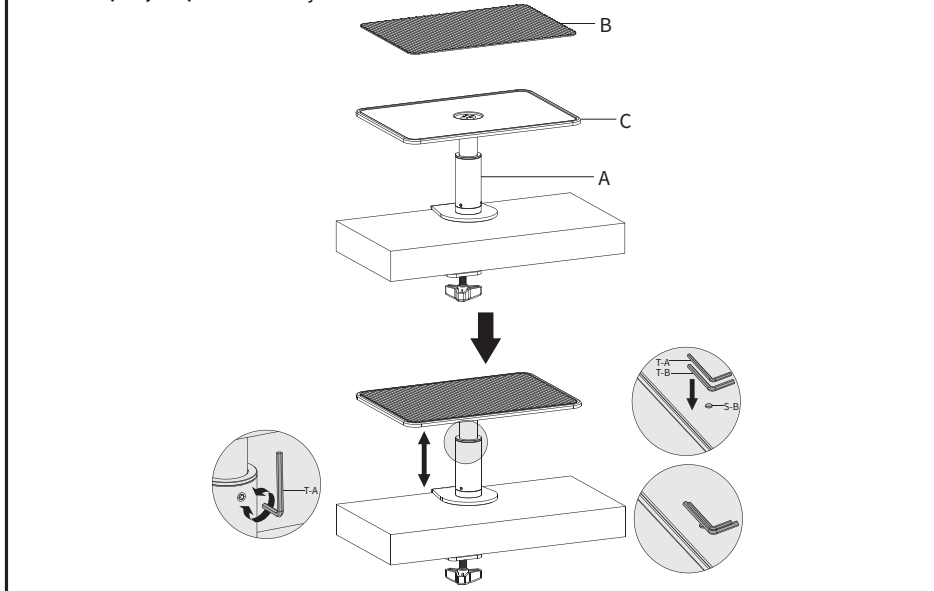

 Love your new VIVO setup and want to share?
Tag us in your photo! **@vivo_us**

LAST UPDATED: 11/12/2021
REV1.1



Open **Monday - Friday 7:00am - 7:00pm** CST,
our dedicated support team can offer immediate assistance with rapid response times. If any parts are received damaged or defective, please contact us. We are happy to replace parts to ensure you have a fully functioning product.



309-278-5303

AVG. RESOLUTION TIME (*within office hrs*): **5M 4S**



www.vivo-us.com
Chat live with an agent!

AVG. RESOLUTION TIME (*within office hrs*): **< 15 M**



help@vivo-us.com

AVG. RESPONSE TIME (*within office hrs*): **1HR 8M**

- 23% within < 15m
- 38% within < 30m
- 61% within < 1hr
- 83% within < 2hr
- 92% within < 3hr

FOR MORE VIVO PRODUCTS, CHECK OUT OUR WEBSITE AT: www.vivo-us.com