

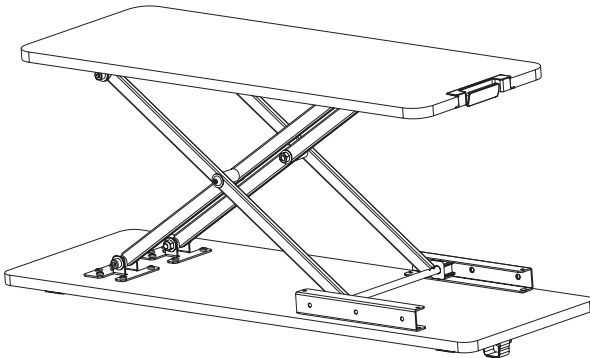

Black Treadmill Desktop Riser

Instruction Manual



SKU: STAND-TDML3



Scan the QR code with your mobile device or follow the link for helpful videos and specifications related to this product.

<https://vivo-us.com/products/stand-tdml3>

GET IN TOUCH | Monday-Friday from 7:00am-7:00pm CST



help@vivo-us.com



www.vivo-us.com
Chat live with an agent!



309-278-5303

WARNING!

If you do not understand these directions, or if you have any doubts about the safety of the installation, please call a qualified technician. Check carefully to make sure there are no missing or defective parts. Improper installation may cause damage or serious injury. Do not use this product for any purpose that is not explicitly specified in this manual and do not exceed weight capacity. We cannot be liable for damage or injury caused by improper mounting, incorrect assembly, or inappropriate use.

WARNING: CHOKING HAZARD

SMALL PARTS - NOT FOR CHILDREN UNDER 3 YEARS. ADULT SUPERVISION IS REQUIRED.

PACKAGE CONTENTS



A (x1)
Desk



B (x4)
Rubber Pad



C (x2)
Strap Bracket

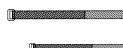

D (x2)
Strap



S-A (x8)
M5x14 Screw

TOOLS NEEDED



Phillips
Screwdriver

DO NOT EXCEED WEIGHT CAPACITY.

Failure to do so may result in serious injury.



 **WARNING** THIS MOUNT IS INTENDED FOR USE WHILE WALKING. DO NOT ATTEMPT TO RUN WHILE USING LAPTOP, AS THIS MAY LEAD TO SERIOUS INJURY.

ASSEMBLY STEPS

STEP 1

Measure the treadmill handlebar distance, then mount the Strap Brackets (**C**) to the corresponding middle row holes in the tray using M5x14 Screws (**S-A**). Mount rubber pads (**B**) to the outer row screw holes using M5x14 Screws (**S-A**). Tighten all screws with a Phillips screwdriver. Do not over tighten these screws.

NOTE: If the treadmill has control buttons on the handlebars, ensure the pads will not be resting on the buttons.

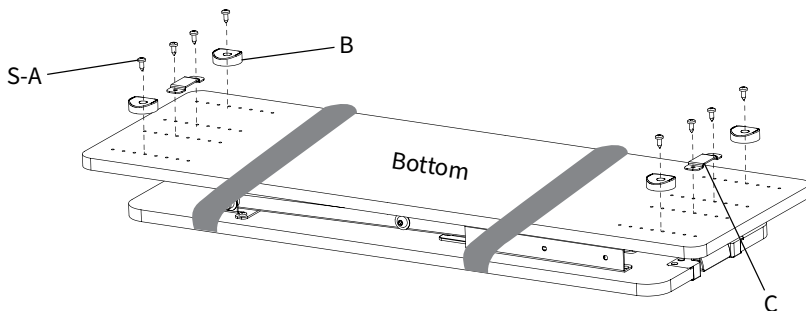

STEP 2

Insert the Straps (D) through the Strap Brackets (C), then secure the assembled Desk (A) to the treadmill handlebars.

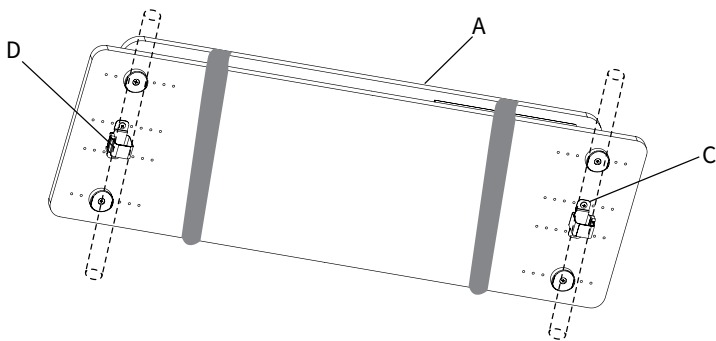

STEP 3

Remove the packaging tie from the Desk (A).

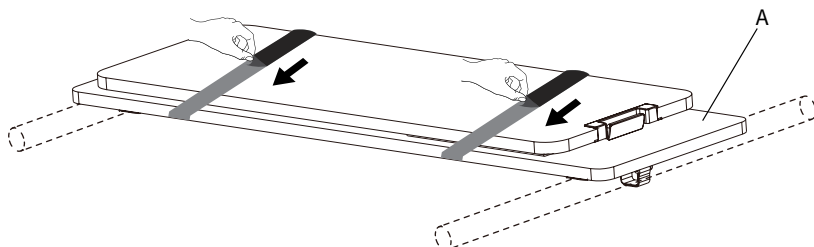

STEP 4

To raise the desk, lift up on the desktop or push in the handle and lift the desktop. Release the handle to lock in place.

To lower the desk, push in the handle and slightly lift the desktop, then lower to desired height and release the handle.

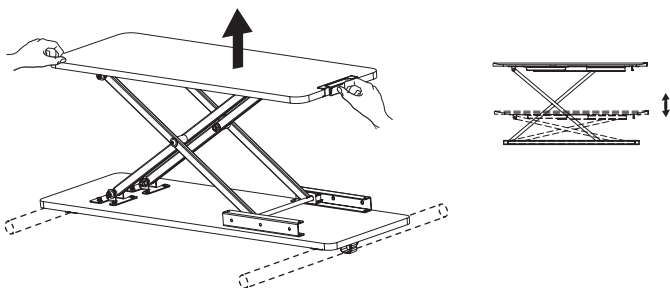



Open **Monday - Friday 7:00am - 7:00pm** CST,
our dedicated support team can offer immediate assistance with rapid response times. If any parts are received damaged or defective, please contact us. We are happy to replace parts to ensure you have a fully functioning product.



309-278-5303

AVG. RESOLUTION TIME (*within office hrs*): **5M 4S**



www.vivo-us.com
Chat live with an agent!

AVG. RESOLUTION TIME (*within office hrs*): **< 15 M**



help@vivo-us.com

AVG. RESPONSE TIME (*within office hrs*): **1HR 8M**

- 23% within < 15m
- 38% within < 30m
- 61% within < 1hr
- 83% within < 2hr
- 92% within < 3hr