

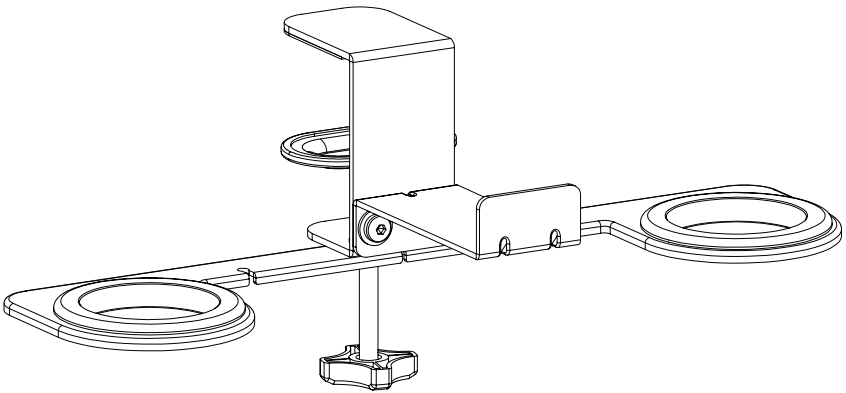

Clamp-on VR Headset Stand

Instruction Manual



SKU: MOUNT-VR01



Scan the QR code with your mobile device or follow the link for helpful videos and specifications related to this product.

<https://vivo-us.com/products/mount-vr01>

GET IN TOUCH | Monday-Friday from 7:00am-7:00pm CST



help@vivo-us.com



www.vivo-us.com
Chat live with an agent!



309-278-5303

WARNING!

If you do not understand these directions, or if you have any doubts about the safety of the installation, please call a qualified technician. Check carefully to make sure there are no missing or defective parts. Improper installation may cause damage or serious injury. Do not use this product for any purpose that is not explicitly specified in this manual. Do not exceed weight capacity. We cannot be liable for damage or injury caused by improper mounting, incorrect assembly or inappropriate use.

WARNING: CHOKING HAZARD

SMALL PARTS - NOT FOR CHILDREN UNDER 3 YEARS. ADULT SUPERVISION IS REQUIRED.

PACKAGE CONTENTS



A (x1)
Clamp

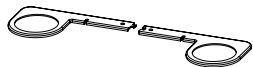

B (x1)
Controller Mount
Set

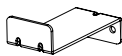

C (x1)
Headset
Bracket

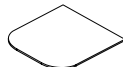

D (x1)
Pad



E (x2)
Rubber
Ring



S-A (x5)
M6x8mm Screws



S-B (x5)
M6 Washer



T-A (x1)
4mm Allen
Wrench

ASSEMBLY STEPS

STEP 1

Remove the protective film from Pad (**D**) and place on inside of Clamp (**A**).

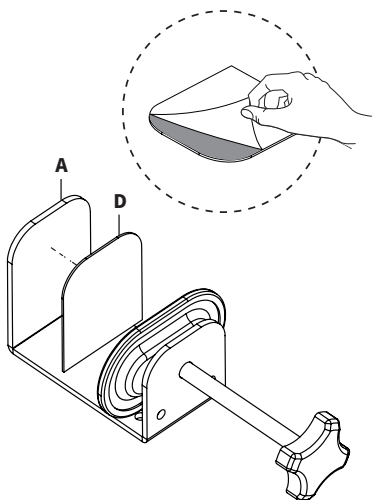

STEP 2

Place Rubber Rings (**E**) into Controller Mount Set (**B**).

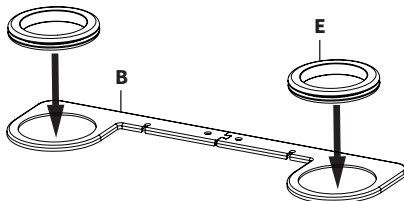

STEP 3

With flanges pointed down, attach Controller Mount Set (**B**) to underside of Clamp (**A**) using M6x8mm Screws (**S-A**), M6 Washer (**S-B**), and 4mm Allen Wrench (**T-A**).

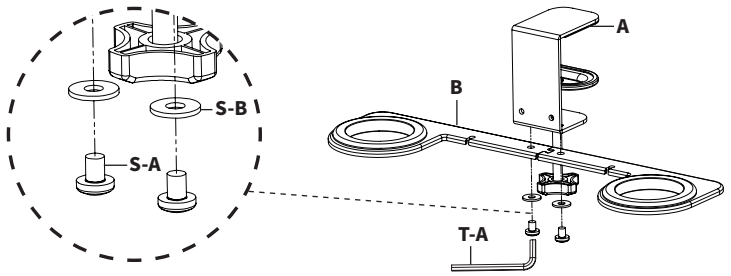

STEP 4

Secure Headset Bracket (**C**) to the back of Clamp (**A**) using M6x8mm Screws (**S-A**), M6 Washer (**S-B**), and 4mm Allen Wrench (**T-A**).

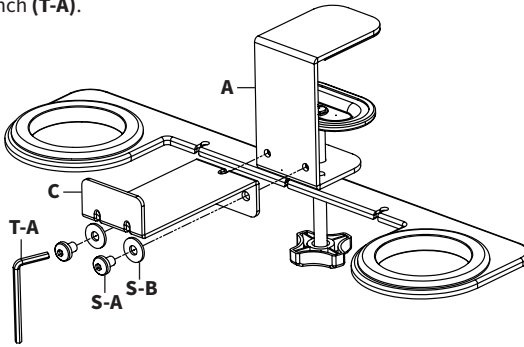

STEP 5

Secure assembly to desktop by tightening hand bolt on Clamp (**A**). Use slots in Controller Mount Set (**B**) to route cables.

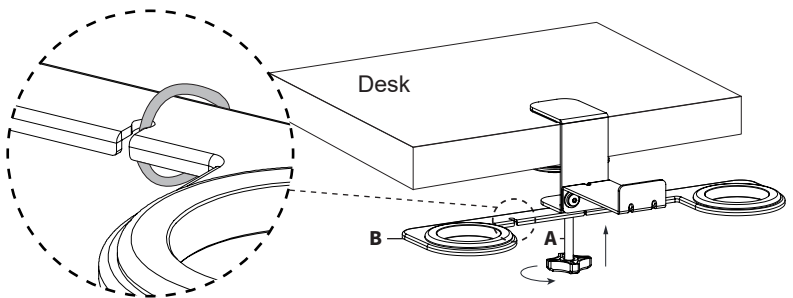

VR mount is now ready for use.

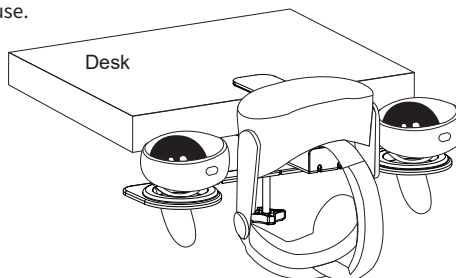



Open **Monday - Friday 7:00am - 7:00pm** CST,
our dedicated support team can offer immediate assistance with rapid response times. If any parts are received damaged or defective, please contact us. We are happy to replace parts to ensure you have a fully functioning product.



309-278-5303

AVG. RESOLUTION TIME (*within office hrs*): **5M 4S**



www.vivo-us.com
Chat live with an agent!

AVG. RESOLUTION TIME (*within office hrs*): **< 15 M**



help@vivo-us.com

AVG. RESPONSE TIME (*within office hrs*): **1HR 8M**

- 23% within < 15m
- 38% within < 30m
- 61% within < 1hr
- 83% within < 2hr
- 92% within < 3hr