

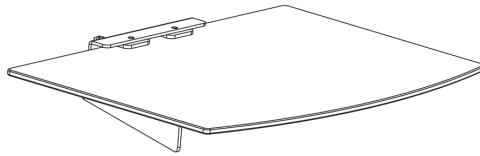

Tempered Glass Floating Wall Shelf

Instruction Manual



SKU: MOUNT-SF011



Scan the QR code with your mobile device or follow the link for helpful videos and specifications related to this product.

<https://vivo-us.com/products/mount-sf011>

GET IN TOUCH | Monday-Friday from 7:00am-7:00pm CST



help@vivo-us.com



www.vivo-us.com
Chat live with an agent!



309-278-5303

⚠ WARNING!

If you do not understand these directions, or if you have any doubts about the safety of the installation, please call a qualified technician. Check carefully to make sure there are no missing or defective parts. Improper installation may cause damage or serious injury. Do not use this product for any purpose that is not explicitly specified in this manual. Do not exceed weight capacity. We cannot be liable for damage or injury caused by improper mounting, incorrect assembly or inappropriate use.

⚠ WARNING: CHOKING HAZARD

SMALL PARTS - NOT FOR CHILDREN UNDER 3 YEARS. ADULT SUPERVISION IS REQUIRED.

PACKAGE CONTENTS

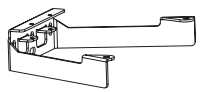

A (x1)
Shelf Bracket



B (x1)
Shelf



C (x2)
Shelf Clip



D (x2)
M5x8



E (x2)
Suction Cup



W-A (x3)
Bolt



W-B (x3)
Anchor



W-C (x3)
Washer

TOOLS NEEDED



Drill



**Phillips
Screwdriver**

DO NOT EXCEED WEIGHT CAPACITY.

Failure to do so may result in serious injury.



⚠ CAUTION!

DO NOT INSTALL INTO DRYWALL ALONE. VERIFY YOUR WALL CONSTRUCTION. USE WOOD STUDS TO MOUNT. We include mounting for brick and concrete walls. If unsure, please contact us at vivo-us.com, email at help@vivo-us.com, or call us at 309-278-5303.

ASSEMBLY STEPS

STEP 1

OPTION A: Wood Stud Wall

Using the shelf bracket (A) as a guide, mark the mounting holes on the wall where a stud is located. With a 5/32" bit, drill approximately 2" into wall. Using bolts (W-A) and washers (W-C), mount the shelf bracket (A) onto wall.

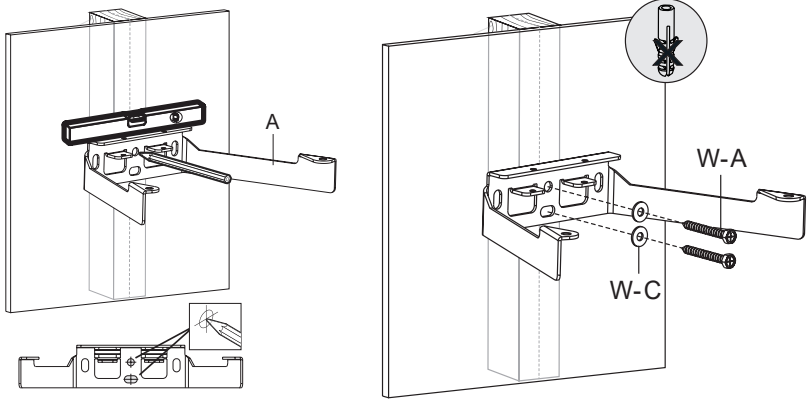

OPTION B: Concrete/Brick Wall

Using shelf bracket (A) as a guide, mark mounting holes on wall. With a 5/16" bit, drill approximately 2.2" into wall and insert anchors (W-B). Secure shelf bracket to wall using bolts (W-A) and washers (W-C).

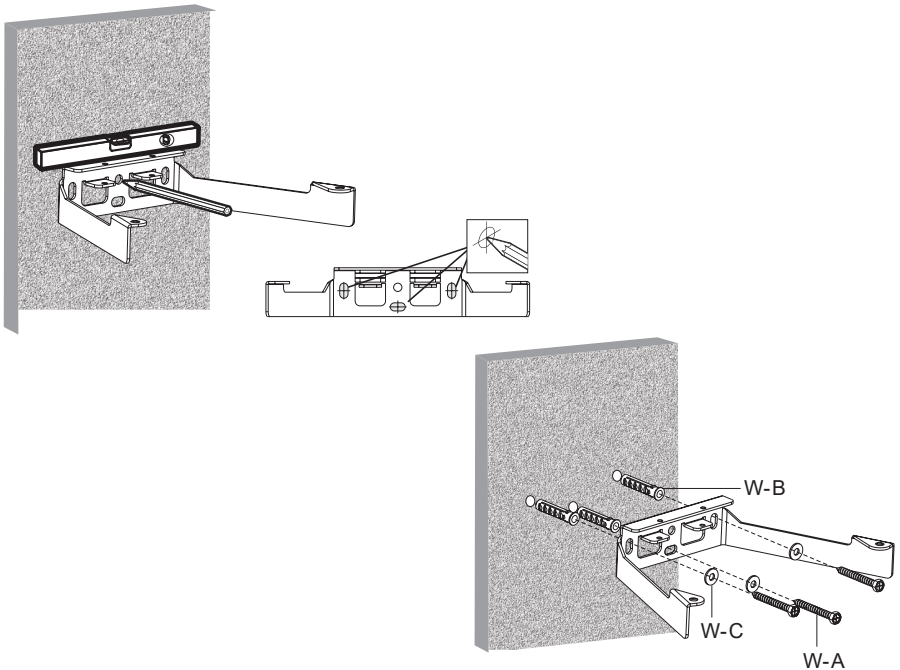

STEP 2

Insert plastic clips (C) into shelf bracket (A).

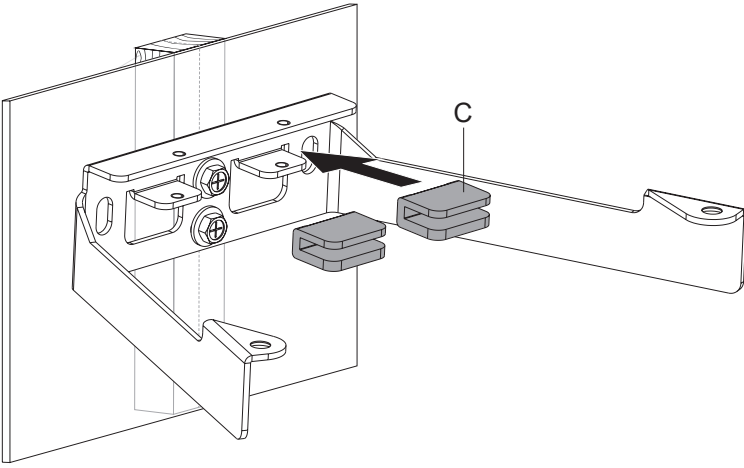

STEP 3

Attach suction cups (E) to shelf bracket (A) as shown in diagram.

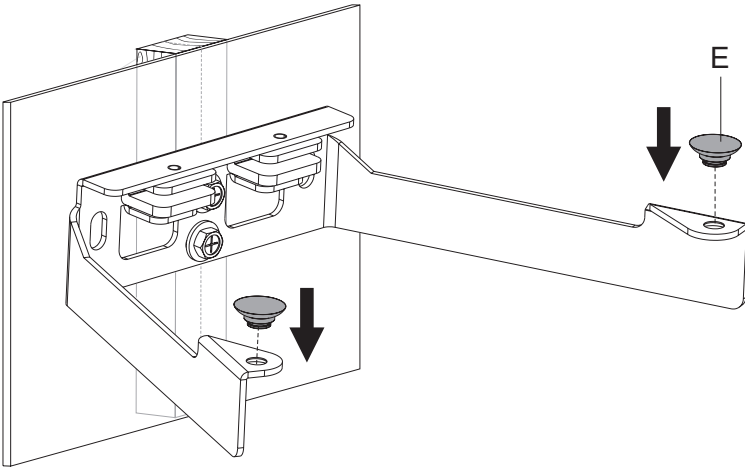

STEP 4

Slide shelf **(B)** into clips **(C)**.

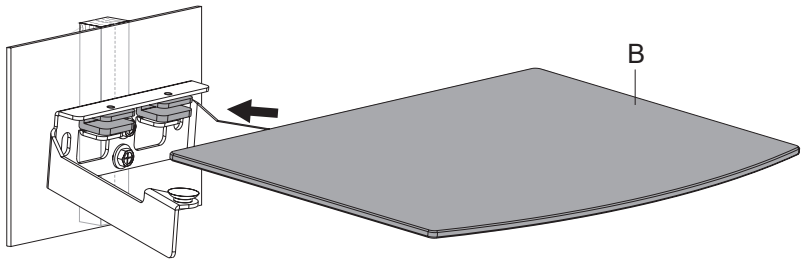

STEP 5

OPTION A:

Tighten M5x8 bolts **(D)** into top of shelf bracket to secure shelf.

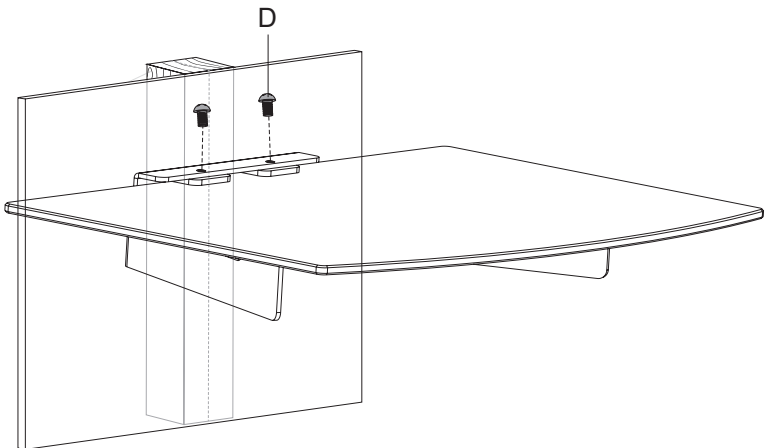

STEP 5 (Continued)

OPTION B:
Tighten M5x8 bolts (D) into bottom of shelf bracket to secure shelf.

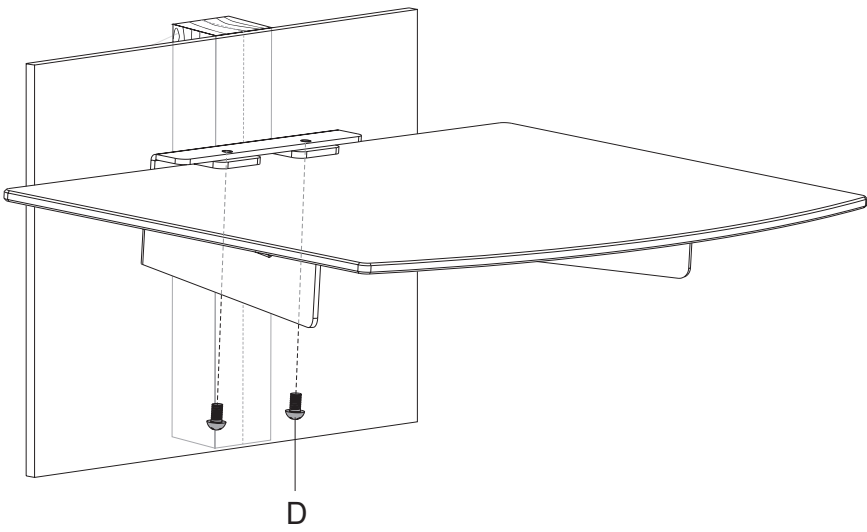

STEP 6

Place desired objects on shelf.

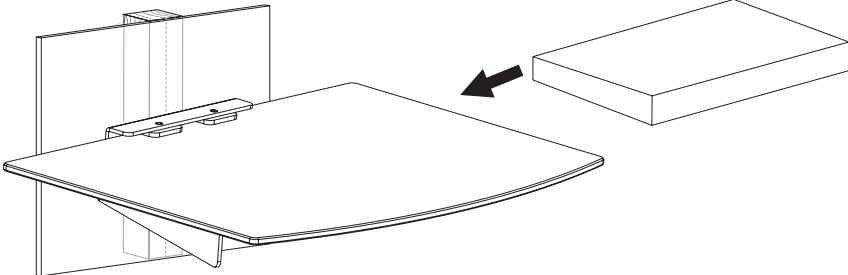



Open **Monday - Friday 7:00am - 7:00pm** CST,

our dedicated support team can offer immediate assistance with rapid response times. If any parts are received damaged or defective, please contact us. We are happy to replace parts to ensure you have a fully functioning product.

 help@vivo-us.com

AVG. RESPONSE TIME (*within office hrs*): **1HR 8M**

- 23% within < 15m
- 38% within < 30m
- 61% within < 1hr
- 83% within < 2hr
- 92% within < 3hr

 www.vivo-us.com
Chat live with an agent!

AVG. RESOLUTION TIME (*within office hrs*): **< 15 M**

 309-278-5303

AVG. RESOLUTION TIME (*within office hrs*): **5M 4S**