

Under Desk Adjustable Strap PC Mount

Instruction Manual

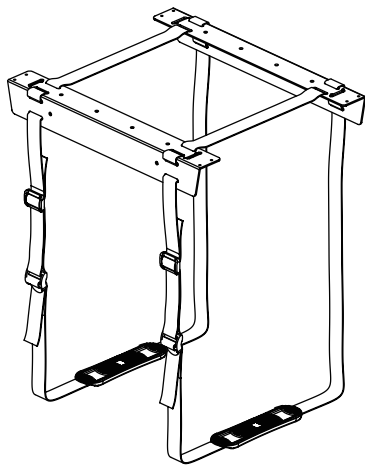

SKU: MOUNT-PC02S



Scan the QR code with your mobile device or follow the link for helpful videos and specifications related to this product.

<https://vivo-us.com/products/mount-pc02s>

GET IN TOUCH | Monday-Friday from 7:00am-7:00pm CST



help@vivo-us.com



www.vivo-us.com
Chat live with an agent!



309-278-5303

WARNING!

If you do not understand these directions, or if you have any doubts about the safety of the installation, please call a qualified technician. Check carefully to make sure there are no missing or defective parts. Improper installation may cause damage or serious injury. Do not use this product for any purpose that is not explicitly specified in this manual. Do not exceed weight capacity. We cannot be liable for damage or injury caused by improper mounting, incorrect assembly or inappropriate use.

WARNING: CHOKING HAZARD

SMALL PARTS - NOT FOR CHILDREN UNDER 3 YEARS. ADULT SUPERVISION IS REQUIRED.

PACKAGE CONTENTS



A (x1)
Mount



B (x4)
Soft Pad



C (x8)
M4x16



D (x2)
Cable Tie

TOOLS NEEDED

DO NOT EXCEED WEIGHT CAPACITY.

Failure to do so may result in serious injury.



Drill



Phillips
Screwdriver

ASSEMBLY STEPS

STEP 1

Place mount (A) on top of CPU and measure distance "a" between mounting holes using a tape measure. Make 8 marks under desktop as shown in diagram.

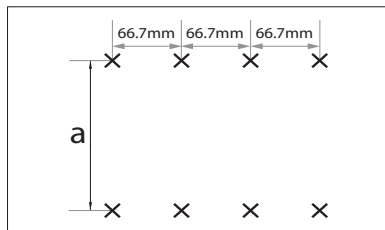
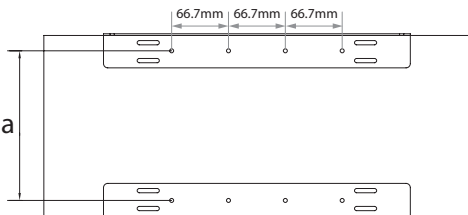

STEP 2

Using a 1/16" bit, drill 3/8" into mounting holes. Attach mount (A) to marked locations using screws (C) and a phillips screwdriver.

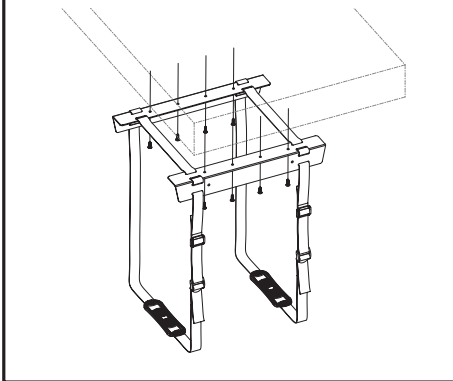

STEP 3

Stick soft pads (B) to mount (A) as shown in diagram.

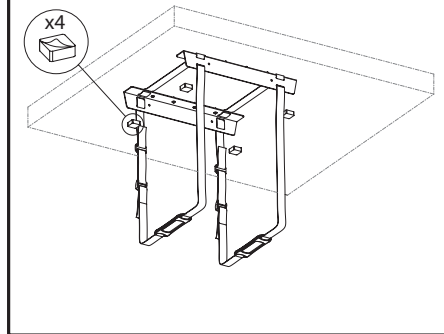

STEP 4

Attach CPU to mount (A) making sure base pads are placed in middle of CPU bottom. Adjust straps to secure CPU in place.

WARNING: If strap gets stuck and won't continue to easily pull through while tightening, STOP and either loosen strap slightly or pull slack through clip before continuing to tighten. Failure to do so may result in breaking the plastic clip.

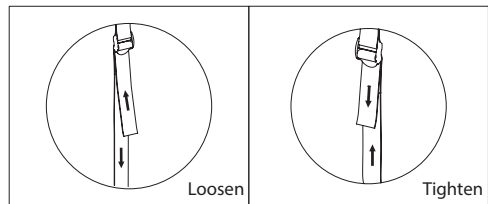
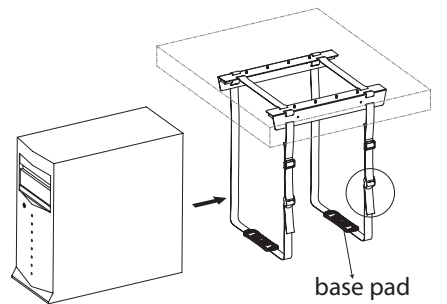

STEP 5

Use cable ties (D) to tie up ends of straps.

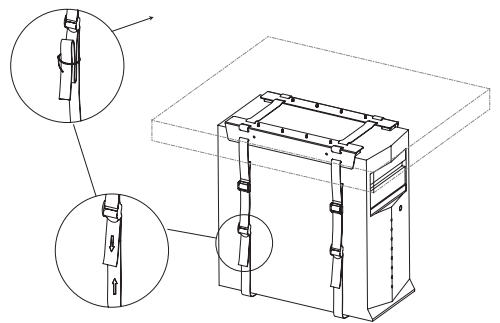



Open **Monday - Friday 7:00am - 7:00pm** CST,
our dedicated support team can offer immediate assistance with rapid response times. If any parts are received damaged or defective, please contact us. We are happy to replace parts to ensure you have a fully functioning product.

 help@vivo-us.com

AVG. RESPONSE TIME (*within office hrs*): **1HR 8M**

- 23% within < 15m
- 38% within < 30m
- 61% within < 1hr
- 83% within < 2hr
- 92% within < 3hr

 www.vivo-us.com
Chat live with an agent!

AVG. RESOLUTION TIME (*within office hrs*): **< 15 M**

 309-278-5303

AVG. RESOLUTION TIME (*within office hrs*): **5M 4S**