

Mini Split Air Conditioner Wall Mount

SKU: MOUNT-MSAC1

Instruction Manual

Assembly Video & Product Info
www.vivo-us.com/products/mount-msac1



! CAUTION! !

If you do not understand these directions, or if you have any doubts about the safety of the installation, please contact our product support team at 309-278-5303 or help@vivo-us.com for further assistance. Check carefully to make sure there are no missing or defective parts. Improper installation may cause damage or serious injury. Do not use this product for any purpose that is not explicitly specified in this manual. Do not exceed weight capacity. We cannot be liable for damage or injury caused by improper mounting, incorrect assembly or inappropriate use.



WARNING: CHOKING HAZARD

SMALL PARTS - NOT FOR CHILDREN UNDER 3 YEARS. ADULT SUPERVISION IS REQUIRED.



DO NOT EXCEED WEIGHT CAPACITY

FAILURE TO DO SO MAY RESULT IN SERIOUS INJURY.



WARNING: DO NOT INSTALL INTO DRYWALL OR WOOD WALLS

THIS MOUNT CAN ONLY BE INSTALLED INTO BRICK/CONCRETE WALLS AND IS NOT INTENDED FOR WOOD WALLS OR DRYWALL.

We're Here for You

Open **Monday - Friday 7:00am - 7:00pm CST**, our dedicated support team can offer immediate assistance with rapid response times. If any parts are received damaged or defective, please contact us. We are happy to replace parts to ensure you have a fully functioning product.



Give us a Call:
309-278-5303

AVG. RESOLUTION TIME (*within office hrs*): **5M 4S**



Chat Us:
www.vivo-us.com

AVG. RESOLUTION TIME (*within office hrs*): **< 15 M**



Email Us:
help@vivo-us.com

AVG. RESPONSE TIME (*within office hrs*): **1HR 8M**

- 23% within < 15m
- 38% within < 30m
- 61% within < 1hr
- 83% within < 2hr
- 92% within < 3hr

Package Contents

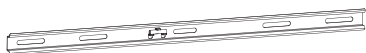

A (x1)
Crossbar

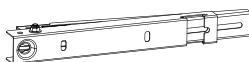

B (x2)
Support
Bracket



C (x4)
Silicone
Spacer



D (x2)
Leveling Pad

Included Hardware & Tools



S-A (x4)
M8x30mm
Screw



S-B (x4)
M8x16mm
Screw



S-C (x8)
M8 Nut



S-D (x8)
M8 Washer



W-A (x5)
ST8x90mm
Screw



W-B (x5)
Concrete Anchor



W-C (x5)
M8 Washer

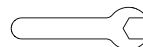

T-A (x2)
Wrench

Tools Needed:



Power Drill



**Tape
Measure**



Pencil



**17mm Socket
Wrench**

Weight Capacity:



ASSEMBLY STEPS

STEP 1

Fold down **Inner Support** from the inside of Support Bracket (**B**).

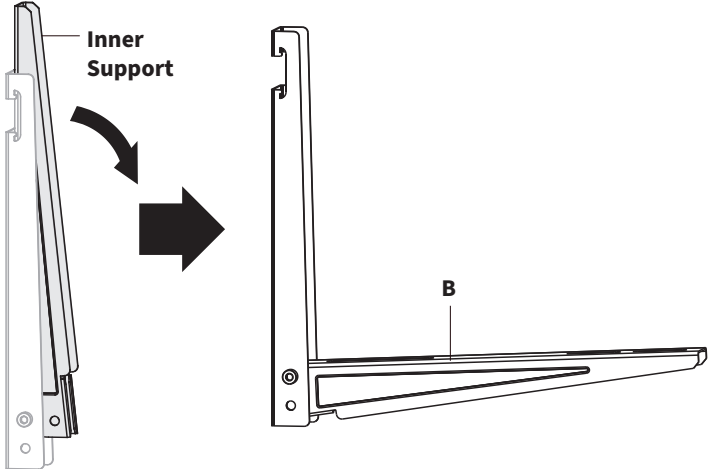

STEP 2

Lock Support Brackets (**B**) in the open position using M8x16mm Screws (**S-B**) and M8 Nuts (**S-C**). Tighten using Wrenches (**T-A**).

- 
S-B (x2)
- 
S-C (x2)
- 
T-A (x2)

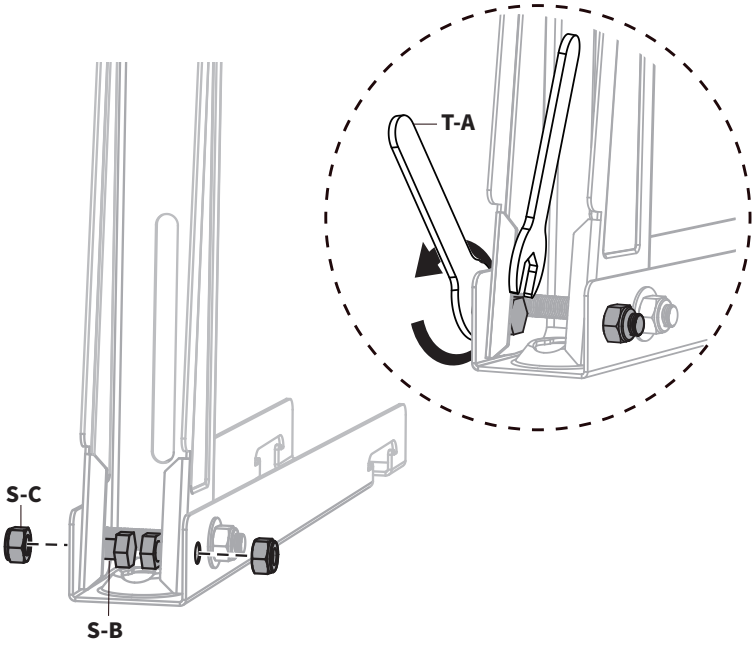

STEP 3

Install the Leveling Pads (**D**) into the back of Support Brackets (**B**). Leveling Pads are used to space the mini split unit mounting brackets off uneven mounting surfaces. They also provide additional leveling support once the AC unit is installed.

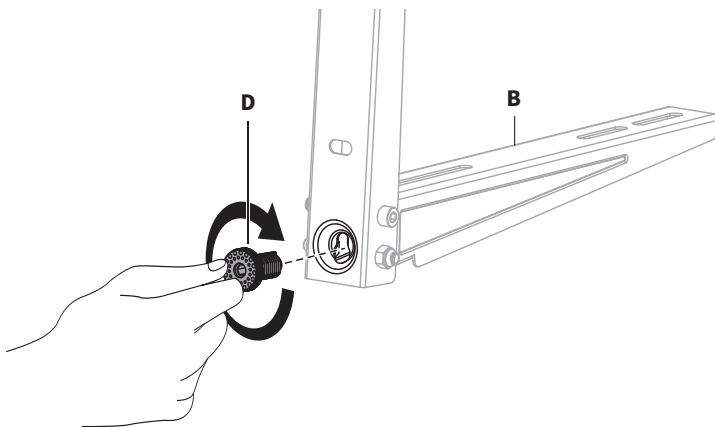

STEP 4

Measure the distance (**1**) between the **Mounting Brackets** on your mini split unit.

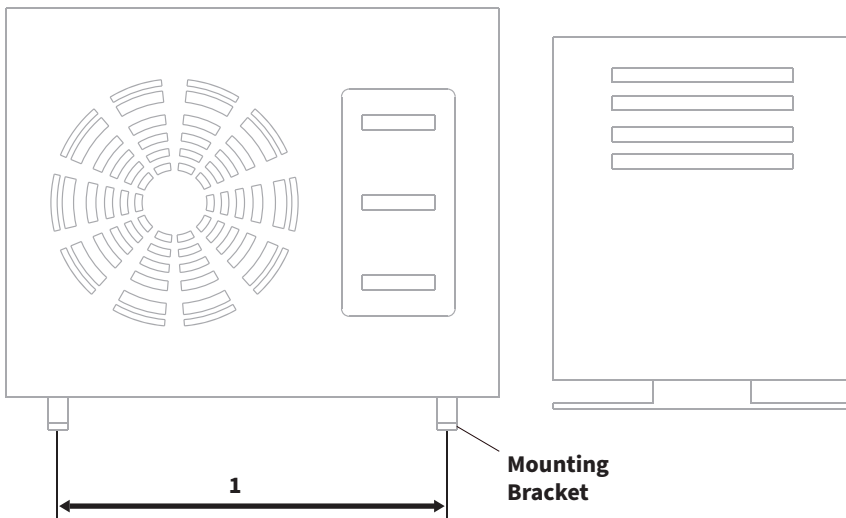

STEP 5

Slide Support Brackets (**B**) onto the sides of Crossbar (**A**).

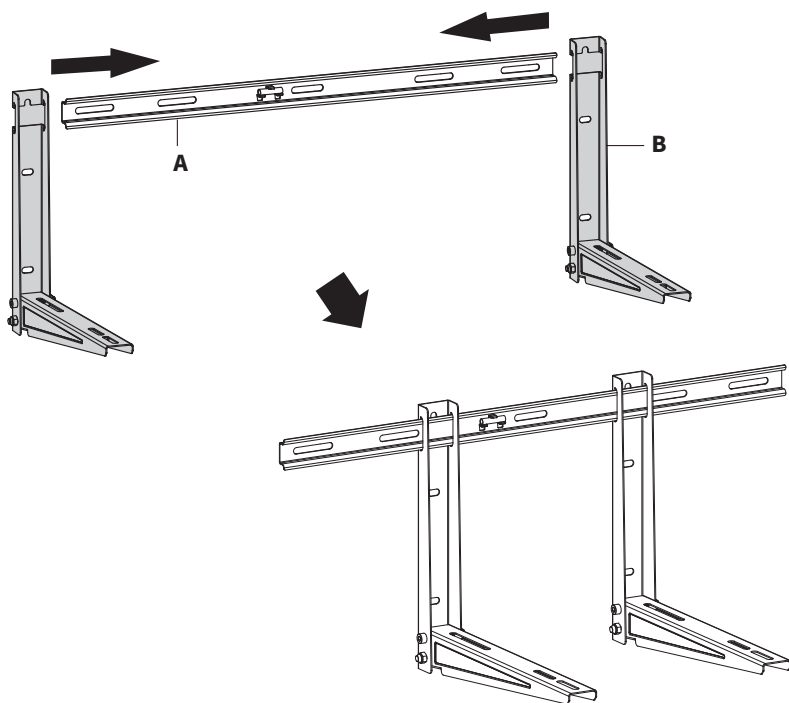

STEP 6

Hold the mount assembly up to your desired mounting location with Support Brackets (**B**) spaced according to the measurement (**1**) taken in STEP 4.

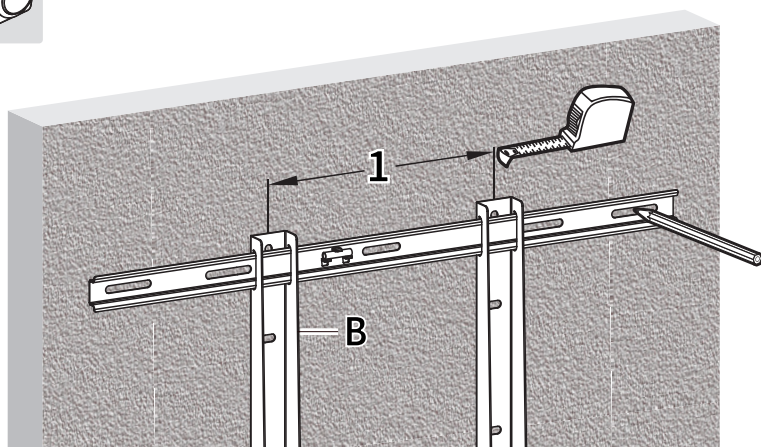

Choose an option below and mark the center of three holes in Crossbar Slots (**A1**) on your intended installation surface.

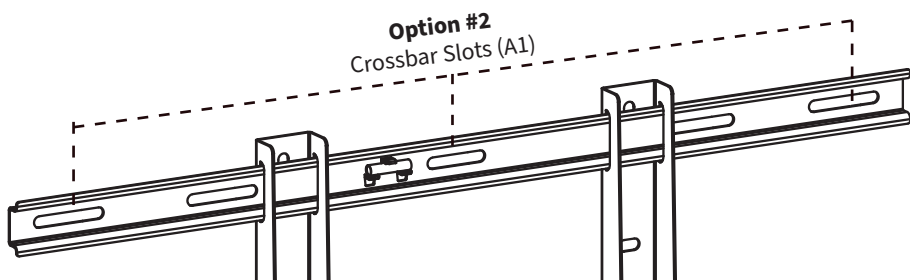
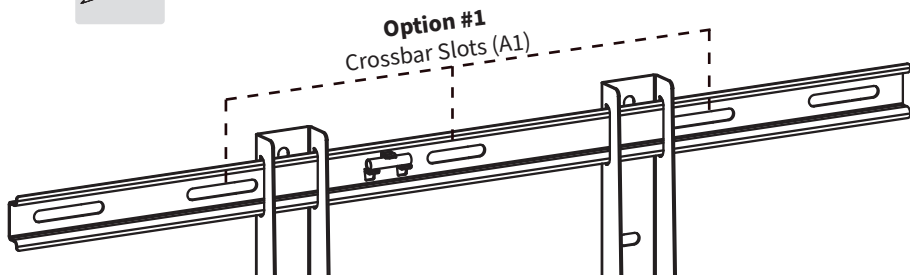

Mark the center of either the top or bottom slot on both Support Bracket (**B**). The same location must be used on both Brackets.

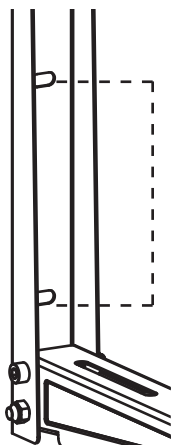

Support Bracket (**B**) Slots
Mark 1 Location

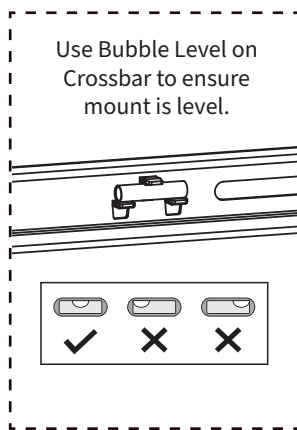

STEP 7

Drill 3.7" (95mm) deep holes using a ½" (12mm) drill bit.

Secure Crossbar (A) and Support Brackets (B) to the wall using ST8x90mm Screws (W-A), M8 Washers (W-B), and Concrete Anchors (W-C). Tighten with a 17mm socket wrench.

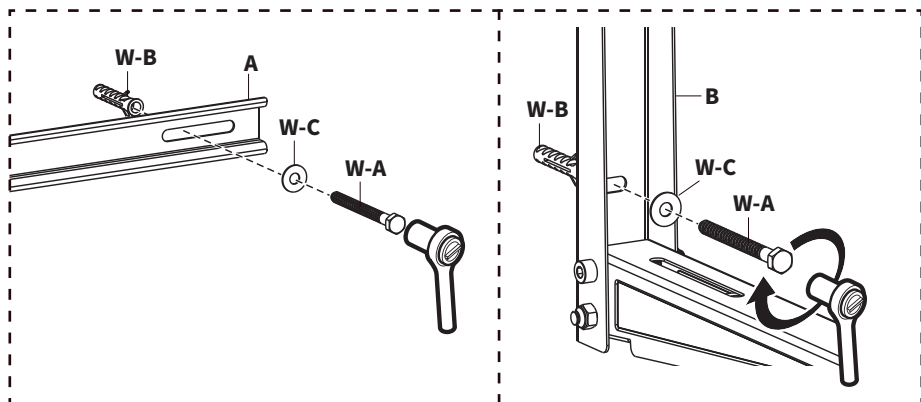
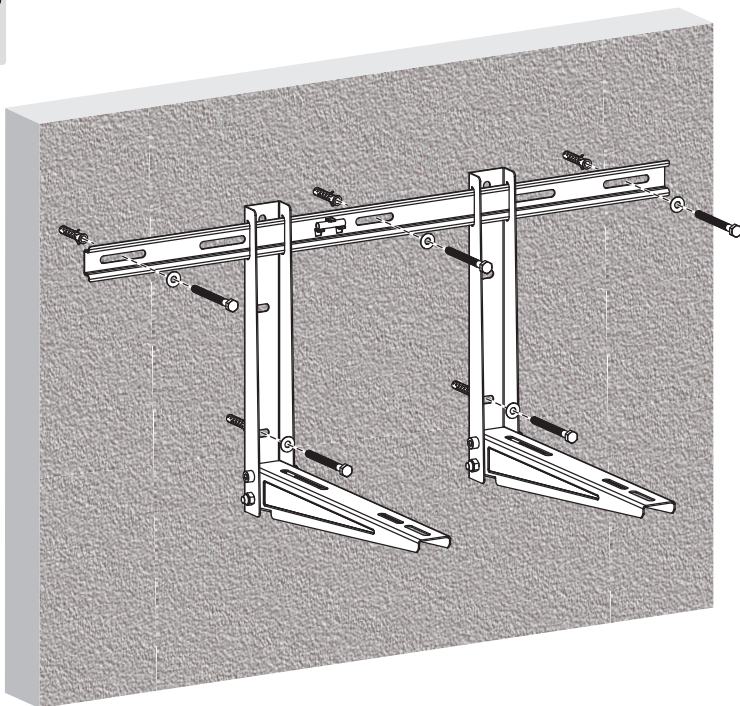
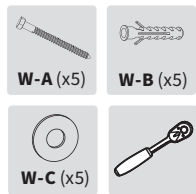

STEP 8

Press Silicone Spacers (**C**) into the slots on Support Brackets (**B**), ensuring they will align with the mounting bracket on your mini split unit when installed.

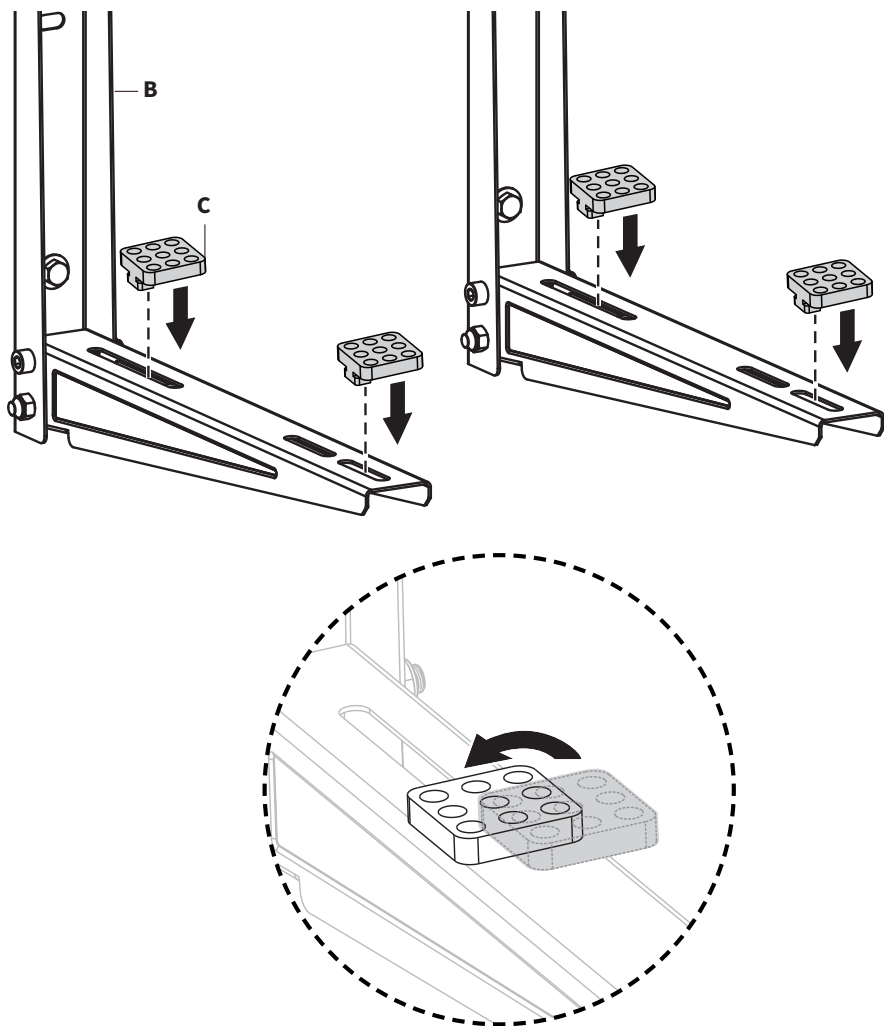

STEP 9

Place your mini split onto Support Brackets **(B)**.

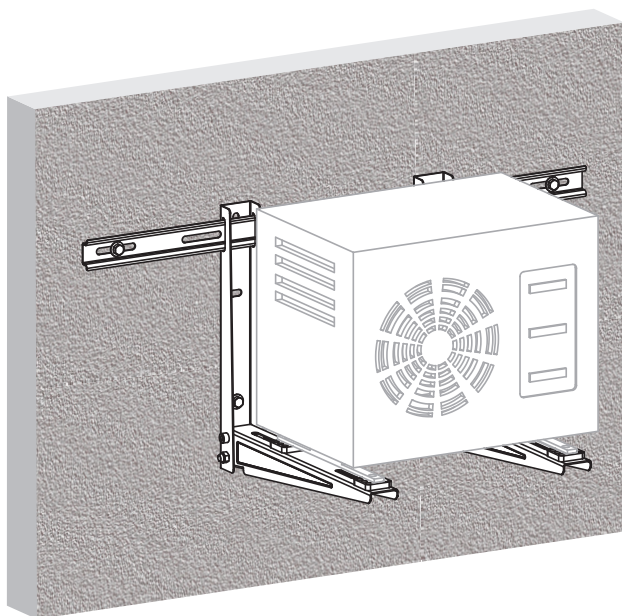
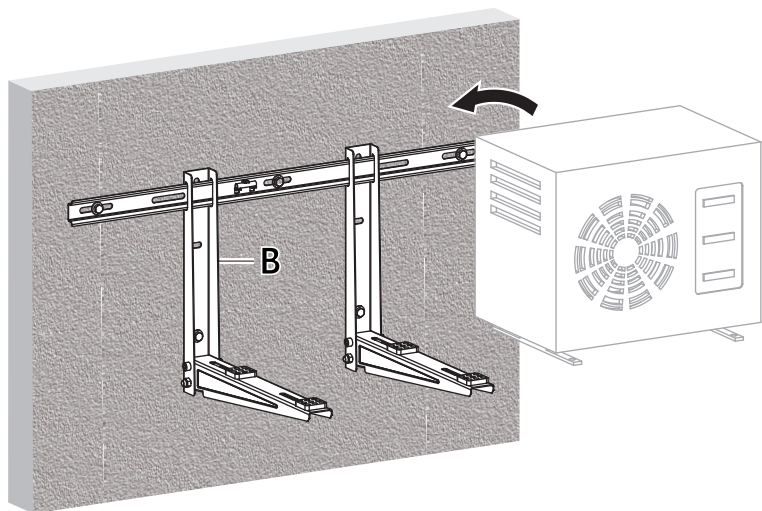

STEP 10

Secure the mini split to Support Brackets (**B**) using M8x30mm Screws (**S-A**), M8 Washers (**S-D**), and M8 Nuts (**S-C**). Tighten using Wrenches (**T-A**).



S-A (x4)



S-C (x4)



S-D (x8)



T-A (x2)

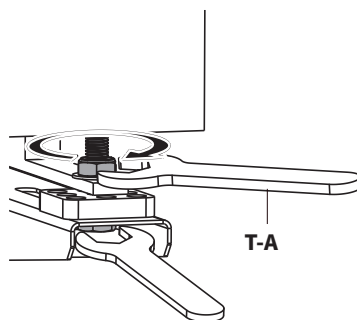
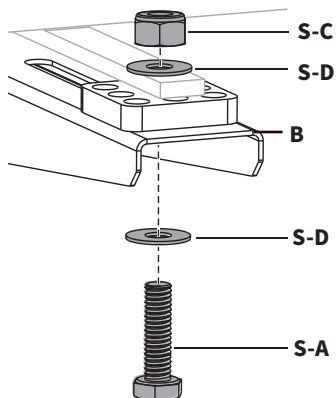
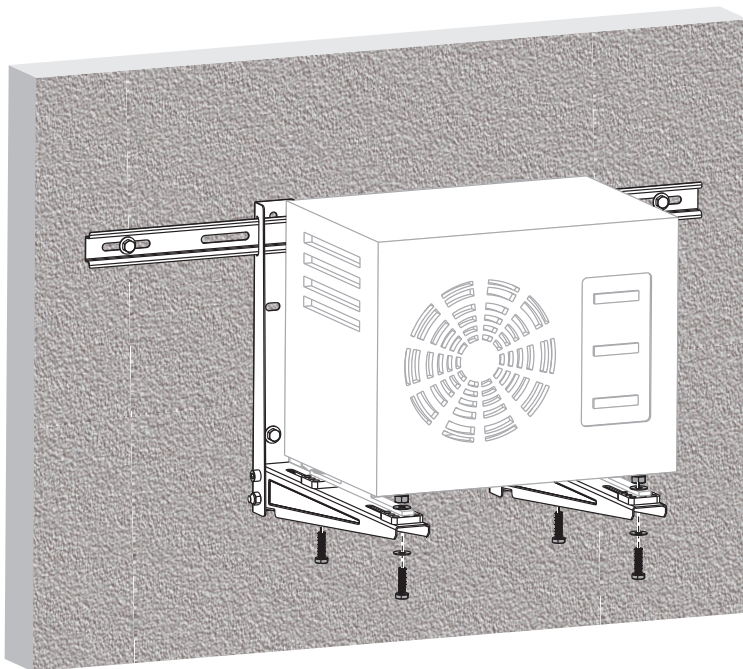

LAST UPDATED: 11/8/23

REV1

v1.0



Need Help? Get In Touch

Monday-Friday from 7:00am-7:00pm CST



help@vivo-us.com



www.vivo-us.com

Chat live with an agent!



309-278-5303



VIVO-us



@vivo_us

FOR MORE GREAT VIVO PRODUCTS,
CHECK OUT OUR WEBSITE AT: WWW.VIVO-US.COM