

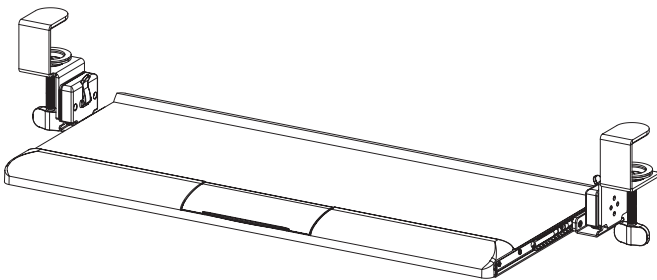

---

## Black Clamp-on Tilting Keyboard Tray

### Instruction Manual



**SKU: MOUNT-KB07T**



Scan the QR code with your mobile device or follow the link for helpful videos and specifications related to this product.

<https://vivo-us.com/products/mount-kb07t>

---

**GET IN TOUCH** | Monday-Friday from 7:00am-7:00pm CST



help@vivo-us.com



www.vivo-us.com  
*Chat live with an agent!*



309-278-5303

# **WARNING!**

If you do not understand these directions, or if you have any doubts about the safety of the installation, please call a qualified technician. Check carefully to make sure there are no missing or defective parts. Improper installation may cause damage or serious injury. Do not use this product for any purpose that is not explicitly specified in this manual. Do not exceed weight capacity. We cannot be liable for damage or injury caused by improper mounting, incorrect assembly or inappropriate use.

# **WARNING: CHOKING HAZARD**

SMALL PARTS - NOT FOR CHILDREN UNDER 3 YEARS. ADULT SUPERVISION IS REQUIRED.

## PACKAGE CONTENTS

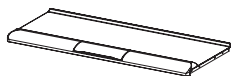

**A (x1)**  
Tray



**B (x2)**  
Sliding Bracket



**C (x1)**  
Left Clamp



**D (x1)**  
Right Clamp



**S-A (x8)**  
M4x6 Screw



**S-B (x4)**  
M5x5 Screw

## TOOLS NEEDED



**Phillips  
Screwdriver**

**DO NOT EXCEED WEIGHT CAPACITY.**

Failure to do so may result in serious injury.

**11lbs  
(5kg)**

## ASSEMBLY STEPS

### STEP 1

Attach Sliding Brackets (**B**) to Tray (**A**) using M4x6 Screws (**S-A**) and a phillips screwdriver.

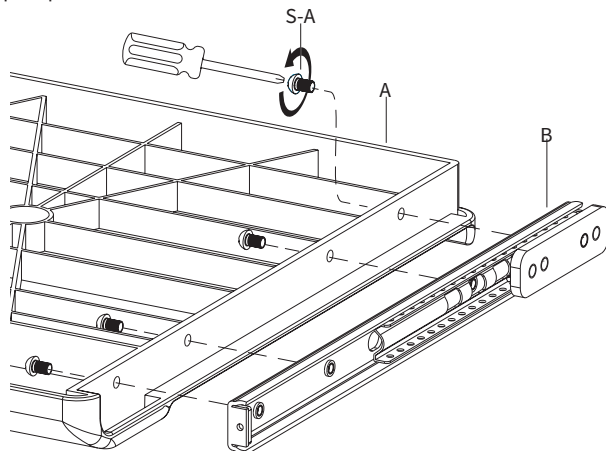

## STEP 2

Attach Right Clamp (D) to Sliding Brackets (B) using M5x5 Screws (S-B) and a phillips screwdriver. repeat the process on the opposite side with Left Clamp (C).

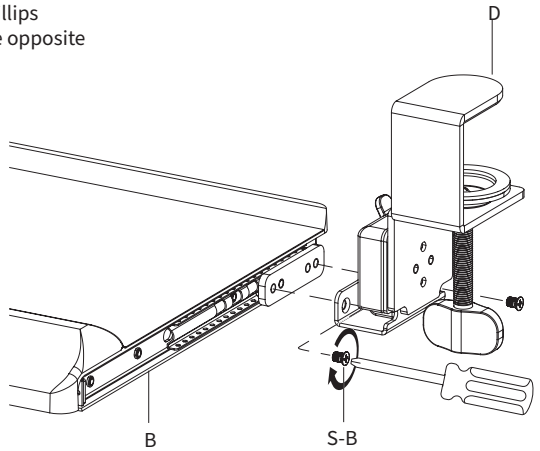

## STEP 3

Place assembled keyboard mount on the edge of the desk and tighten clamps.

**NOTE:** To ensure keyboard tray is level, do not over-tighten clamps.

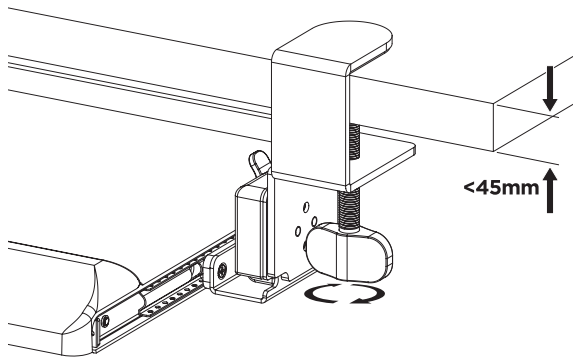

## STEP 4

Use the locks on Left Clamp (C) and Right Clamp (D) to adjust the tilt, and secure the tray in place.

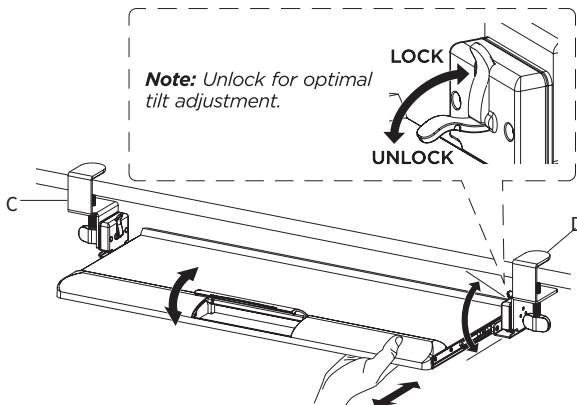



Open **Monday - Friday 7:00am - 7:00pm** CST,  
our dedicated support team can offer immediate assistance with rapid response times. If any parts are received damaged or defective, please contact us. We are happy to replace parts to ensure you have a fully functioning product.

 309-278-5303

**AVG. RESOLUTION TIME** (*within office hrs*): **5M 4S**

 [www.vivo-us.com](http://www.vivo-us.com)  
*Chat live with an agent!*

**AVG. RESOLUTION TIME** (*within office hrs*): **< 15 M**

 [help@vivo-us.com](mailto:help@vivo-us.com)

**AVG. RESPONSE TIME** (*within office hrs*): **1HR 8M**

- 23% within < 15m
- 38% within < 30m
- 61% within < 1hr
- 83% within < 2hr
- 92% within < 3hr