

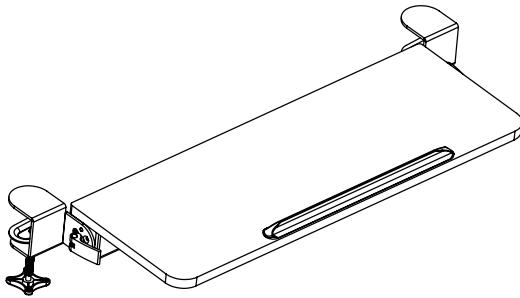

Black Clamp-on Keyboard Tray

Instruction Manual



SKU: MOUNT-KB06H



Scan the QR code with your mobile device or follow the link for helpful videos and specifications related to this product.

<https://vivo-us.com/products/mount-kb06h>

GET IN TOUCH | Monday-Friday from 7:00am-7:00pm CST



help@vivo-us.com



www.vivo-us.com
Chat live with an agent!



309-278-5303

WARNING!

If you do not understand these directions, or if you have any doubts about the safety of the installation, please call a qualified technician. Check carefully to make sure there are no missing or defective parts. Improper installation may cause damage or serious injury. Do not use this product for any purpose that is not explicitly specified in this manual. Do not exceed weight capacity. We cannot be liable for damage or injury caused by improper mounting, incorrect assembly or inappropriate use.

WARNING: CHOKING HAZARD

SMALL PARTS - NOT FOR CHILDREN UNDER 3 YEARS. ADULT SUPERVISION IS REQUIRED.

PACKAGE CONTENTS

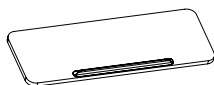

A (x1)
Keyboard Tray



B (x2)
Clamp



C (x2)
Clamp Bracket



D (x2)
Pad



S-A (x6)
M5x14mm Screw

TOOLS NEEDED



DO NOT EXCEED WEIGHT CAPACITY.

Failure to do so may result in serious injury.



ASSEMBLY STEPS

STEP 1

Mount Clamps (**B**) to Keyboard Tray (**A**) using Clamp Brackets (**C**) with M5x14mm Screws (**S-A**), and tighten with a Phillips screwdriver.

Please note, the clamps are delivered in the flipped position. The rear edge of the tray will face forward until later.

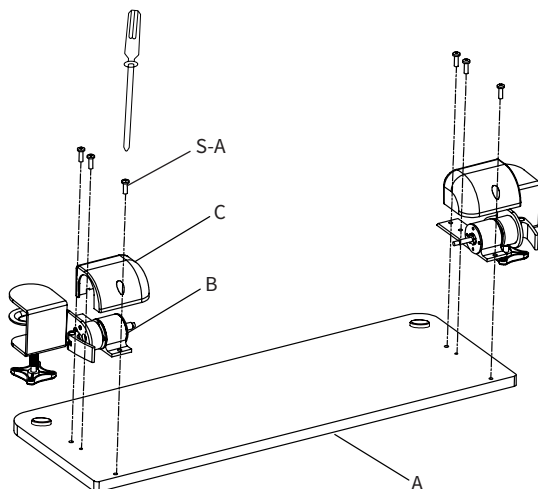

STEP 2

Open Clamps **(B)** by unscrewing the hand bolts, then apply Pads **(D)** to the underside of Clamps **(B)**.

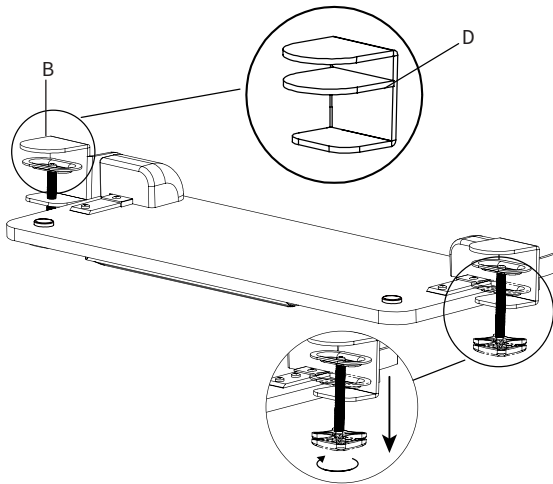

STEP 3

Place the assembled keyboard mount on the edge of the desk and tighten Clamps **(B)** to secure.

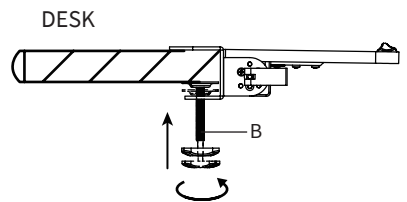
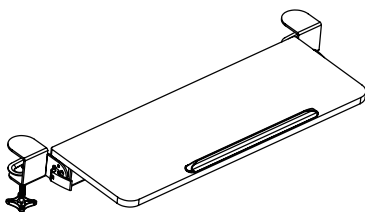

NOTE: Only supports 0 - 40mm thick desk

STEP 4

Flip the lever on each Clamp **(B)** to the open position, then rotate Keyboard Tray **(A)** to the forward position. Flip the levers to the closed position to lock the tray.

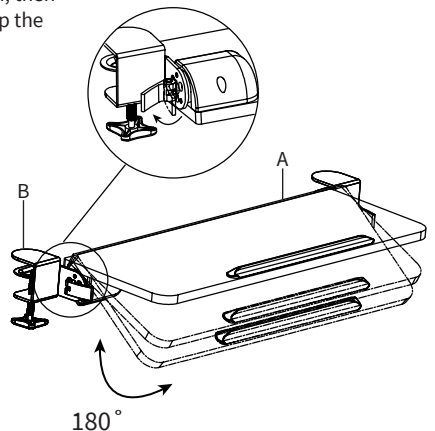



Open **Monday - Friday 7:00am - 7:00pm** CST,
our dedicated support team can offer immediate assistance with rapid response times. If any parts are received damaged or defective, please contact us. We are happy to replace parts to ensure you have a fully functioning product.



309-278-5303

AVG. RESOLUTION TIME (*within office hrs*): **5M 4S**



www.vivo-us.com
Chat live with an agent!

AVG. RESOLUTION TIME (*within office hrs*): **< 15 M**



help@vivo-us.com

AVG. RESPONSE TIME (*within office hrs*): **1HR 8M**

- 23% within < 15m
- 38% within < 30m
- 61% within < 1hr
- 83% within < 2hr
- 92% within < 3hr