

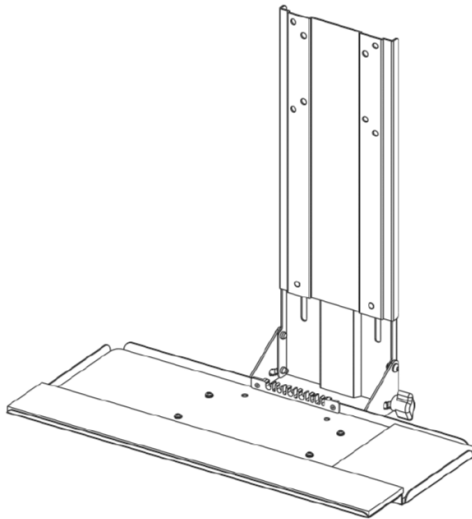

VESA Keyboard Tray - Black

Instruction Manual



SKU: MOUNT-KB02



Scan the QR code with your mobile device or follow the link for helpful videos and specifications related to this product.

<https://vivo-us.com/products/mount-kb02>

GET IN TOUCH | Monday-Friday from 7:00am-7:00pm CST



help@vivo-us.com



www.vivo-us.com
Chat live with an agent!



309-278-5303

WARNING!

If you do not understand these directions, or if you have any doubts about the safety of the installation, please call a qualified technician. Check carefully to make sure there are no missing or defective parts. Improper installation may cause damage or serious injury. Do not use this product for any purpose that is not explicitly specified in this manual. Do not exceed weight capacity. We cannot be liable for damage or injury caused by improper mounting, incorrect assembly or inappropriate use.

WARNING: CHOKING HAZARD

SMALL PARTS - NOT FOR CHILDREN UNDER 3 YEARS. ADULT SUPERVISION IS REQUIRED.

PACKAGE CONTENTS

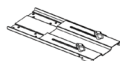

A (x1)

Vertical Board

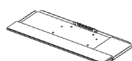

B (x1)

Keyboard Tray



C (x1)

Tray
Supporter



C2 (x1)

Tray
Supporter



D (x4)

M4x16



E (x4)

M4x30



F (x4)

M4 Spacer



G (x8)

M4 Washer



H (x4)

3mm Spacer



I (x4)

Plastic Washer



J (x2)

M5x10 Bolt



K (x2)

Plastic Knob



L (x4)

M4x6



M (x1)

Allen Key

TOOLS NEEDED

NOTE: NOT ALL HARDWARE INCLUDED WILL BE USED



Phillips
Screwdriver

DO NOT EXCEED WEIGHT CAPACITY.

Failure to do so may result in serious injury.



ASSEMBLY STEPS

STEP 1

Mount Vertical Board (**A**) between your monitor and the existing VESA mount using Bolts (**D**, **E**), Washers (**G**), and Spacers (**H**) as shown in diagram. Use spacer (**F**) if necessary.

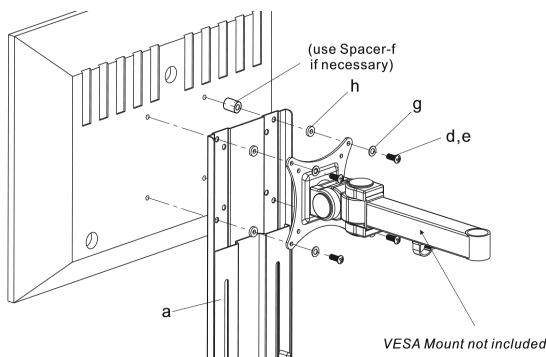

STEP 2

Connect Tray Supporters (**C1, C2**) to Vertical Board (**A**). Use Bolts (**J**), Plastic Knobs (**K**), and Plastic Washer (**I**) as shown in the diagram. Use the Allen Key (**M**) to tighten the bolts.

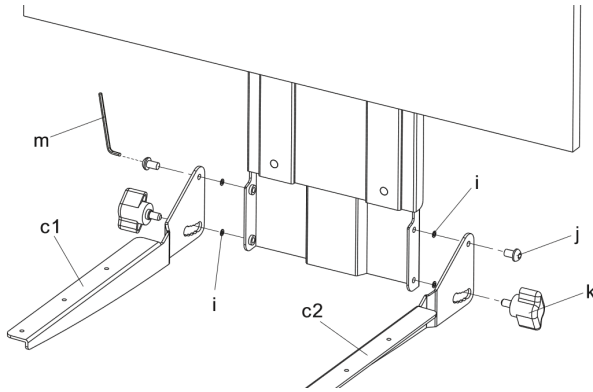

STEP 3

Attach Keyboard Tray (**B**) to Tray Supporters (**C1, C2**). Use Bolts (**L**) and Washers (**G**).

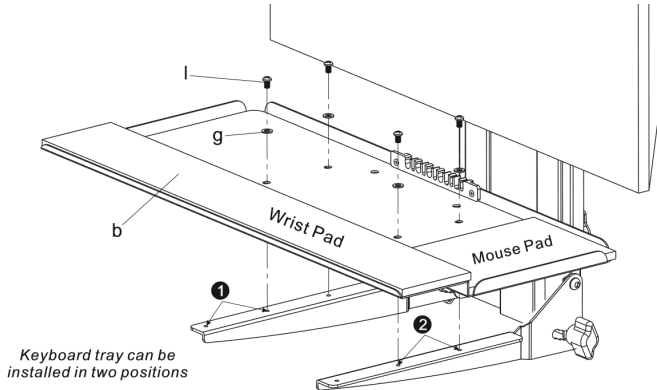

STEP 4

Adjust the height using this knob.

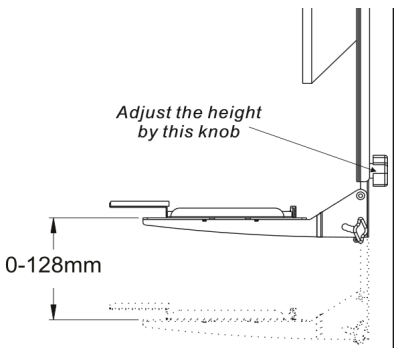

STEP 5

Adjust the tilt angle using this knob.

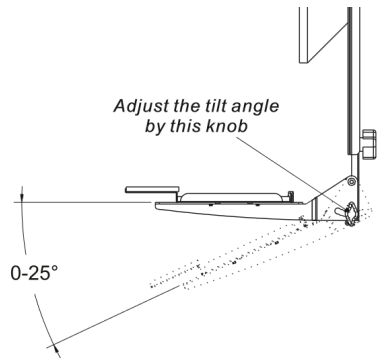



Open **Monday - Friday 7:00am - 7:00pm** CST,

our dedicated support team can offer immediate assistance with rapid response times. If any parts are received damaged or defective, please contact us. We are happy to replace parts to ensure you have a fully functioning product.

 help@vivo-us.com

AVG. RESPONSE TIME (*within office hrs*): **1HR 8M**

- 23% within < 15m
- 38% within < 30m
- 61% within < 1hr
- 83% within < 2hr
- 92% within < 3hr

 www.vivo-us.com
Chat live with an agent!

AVG. RESOLUTION TIME (*within office hrs*): **< 15 M**

 309-278-5303

AVG. RESOLUTION TIME (*within office hrs*): **5M 4S**