



---

## 42.5" - 73.6" Electric Height Adjustable Desk Frame Instruction Manual



**SKU: DESK-V110EW**



Scan the QR code with your mobile device or follow the link for helpful videos and specifications related to this product.

<https://vivo-us.com/products/desk-v110ew>



help@vivo-us.com



www.vivo-us.com



1-800-371-5654

**⚠ WARNING!**

If you do not understand these directions, or if you have any doubts about the safety of the installation, please call a qualified technician. Check carefully to make sure there are no missing or defective parts. Improper installation may cause damage or serious injury. Do not use this product for any purpose that is not explicitly specified in this manual and do not exceed weight capacity. We cannot be liable for damage or injury caused by improper mounting, incorrect assembly, or inappropriate use.

**⚠ ELECTRICAL SAFETY INSTRUCTIONS**

THIS PRODUCT IS POWERED BY ELECTRICITY. IN ORDER TO AVOID BURNS, FIRE AND ELECTRIC SHOCK, PLEASE READ THE FOLLOWING INSTRUCTIONS CAREFULLY.

- DO NOT CLEAN PRODUCT WHILE POWER IS CONNECTED.
- DO NOT DISASSEMBLE OR REPLACE COMPONENTS WHILE POWER IS CONNECTED.
- NEVER OPERATE THE SYSTEM WITH A DAMAGED CORD OR PLUG. PLEASE CONTACT YOUR SELLER TO REPLACE DAMAGED PARTS.
- NEVER OPERATE SYSTEM IN DAMP ENVIRONMENTS OR IF ANY ELECTRICAL COMPONENTS HAVE MADE CONTACT WITH LIQUIDS.
- ALTERATIONS OF THE GIVEN POWER UNIT ARE NOT ALLOWED.
- OUTDOOR USE IS PROHIBITED.

**PACKAGE CONTENTS**

<b>1</b> (x1) Control Panel	<b>7</b> (x4) Foot Pad
<b>2</b> (x2) Side Bracket	<b>8</b> (x1) Control Unit
<b>3</b> (x1) Extension Cord	<b>9</b> (x1) Sync Rod
<b>4</b> (x2) Frame	<b>10</b> (x2) Crossbar
<b>5</b> (x2) Leg	<b>11</b> (x1) Power Cord
<b>6</b> (x2) Foot	<b>12</b> (x1) Desktop

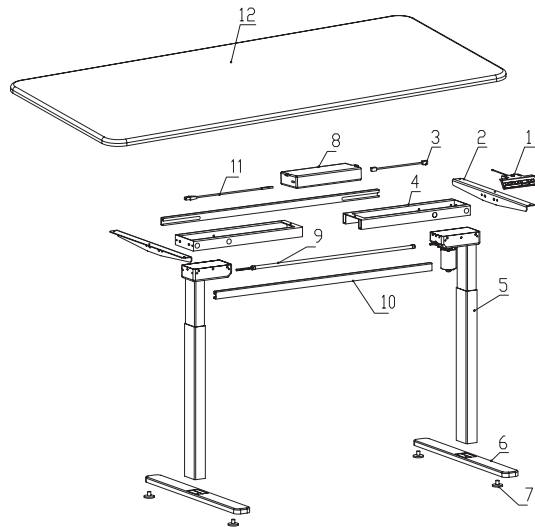

**A** (x24)  
M6x12



**B** (x12)  
M5x16



**C** (x1)  
Allen Key

**TOOLS NEEDED**



**⚠ WARNING**  
**PINCH POINT**  
DO NOT place hands on or near support bars. Moving parts can crush and cut. Pinch points are created during lifting and lowering the worksurface. Failure to follow these instructions may result in serious personal injury.

DO NOT EXCEED WEIGHT CAPACITY.  
Failure to do so may result in serious injury.



**ASSEMBLY STEPS**

**STEP 1**

Place the frames (**4**) upside down and align pre-installed screws on the legs (**5**) with the slots. Set the legs into the frames and tighten screws with the 4mm Allen wrench (**C**). Screw foot pads (**7**) into the feet (**6**), then attach the feet to the legs using x8 M6x12 screws (**A**) and tighten with the Allen key. **NOTE:** Insert all necessary screws into holes before completely tightening.

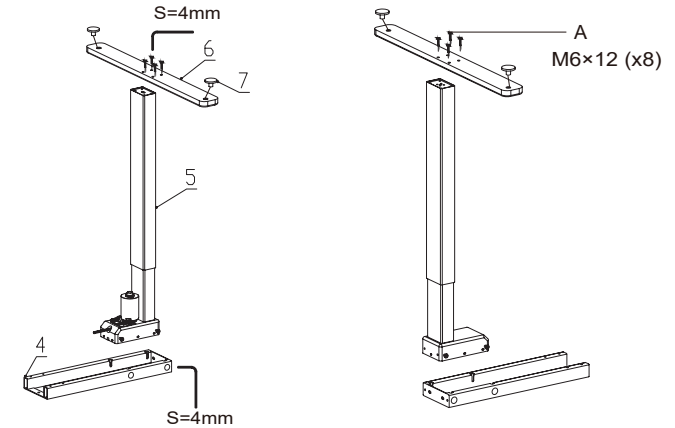

**STEP 2**

Turn assembled legs with frames right side up, then slide the crossbars (**10**) into the frames. Attach the side brackets (**2**) to the frames using x8 M6x12 screws (**A**) and tighten with the Allen key (**C**).

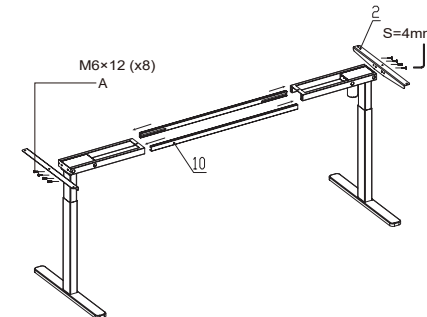

### STEP 3

Adjust the width of the frame to fit your desktop. Tighten x8 M6x12 screws (A) into the underside of the frames (4) to secure the adjusted length.

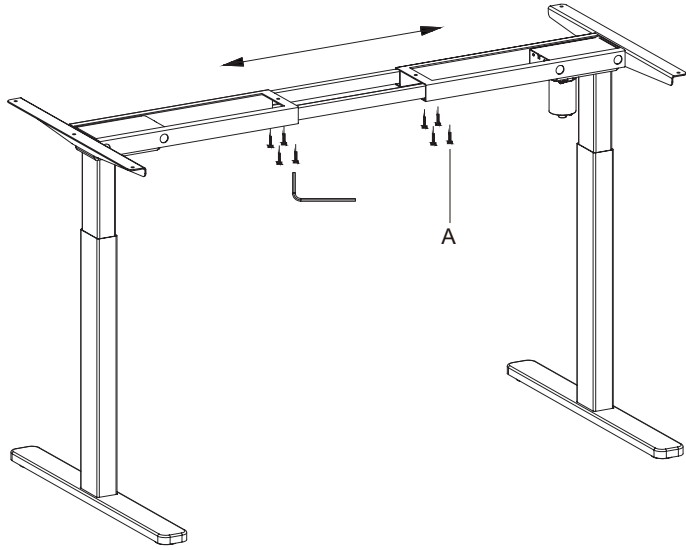

### STEP 4

Loosen the nut on the socket end of the sync rod (9), slide the rod onto the protruding shaft of the motorized leg, then tighten the nut. Loosen the nut on the shaft end of the sync rod (9), slide the shaft into the socket of the non-motorized leg, then tighten the nut.

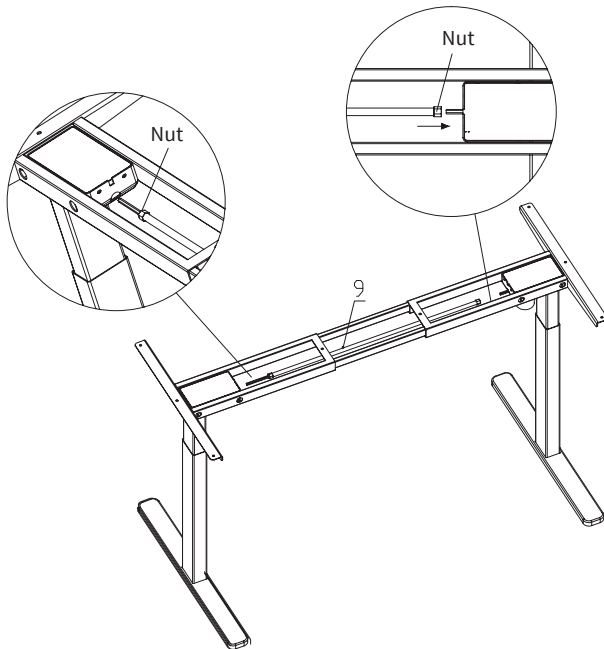

### STEP 5

Attach your desktop (12) to the assembled desk frame using x8 M5x16 screws (B). Mount the control panel (1) and control unit (8) to the underside of the desktop using x4 M5x16 screws (B). Use the extension cord (3) to connect the motor to the control unit (8), then connect the control panel and power cord (11).

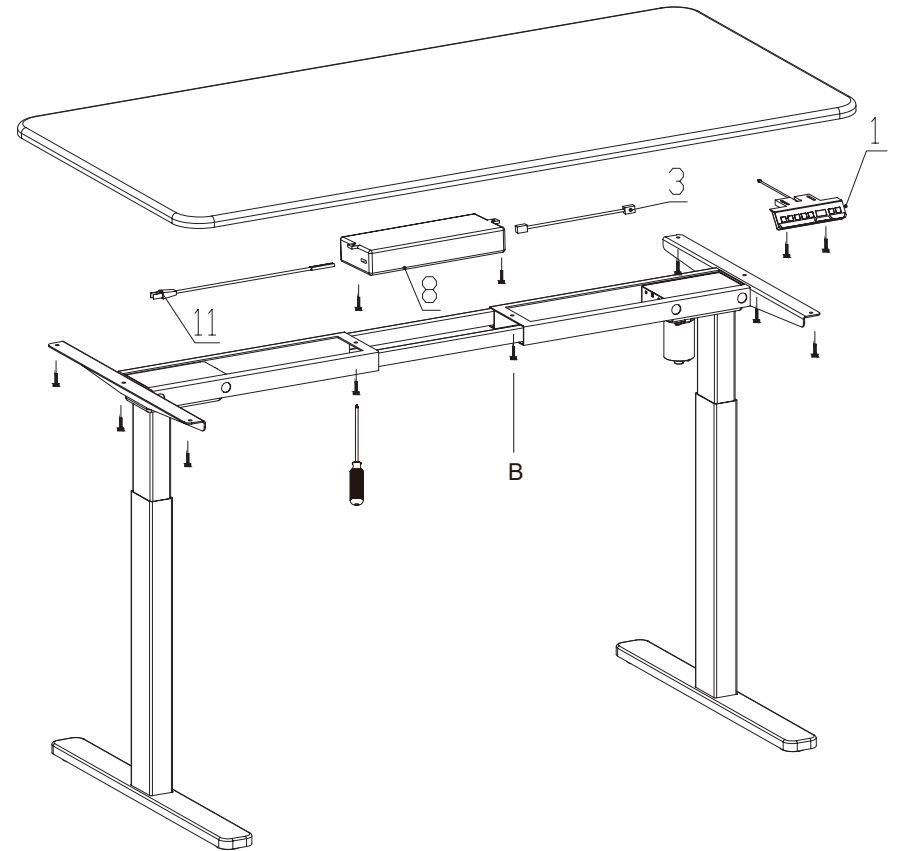

## Step 6

Plug the power cable (11) into an AC wall outlet, then use the control panel (1) to adjust the height.

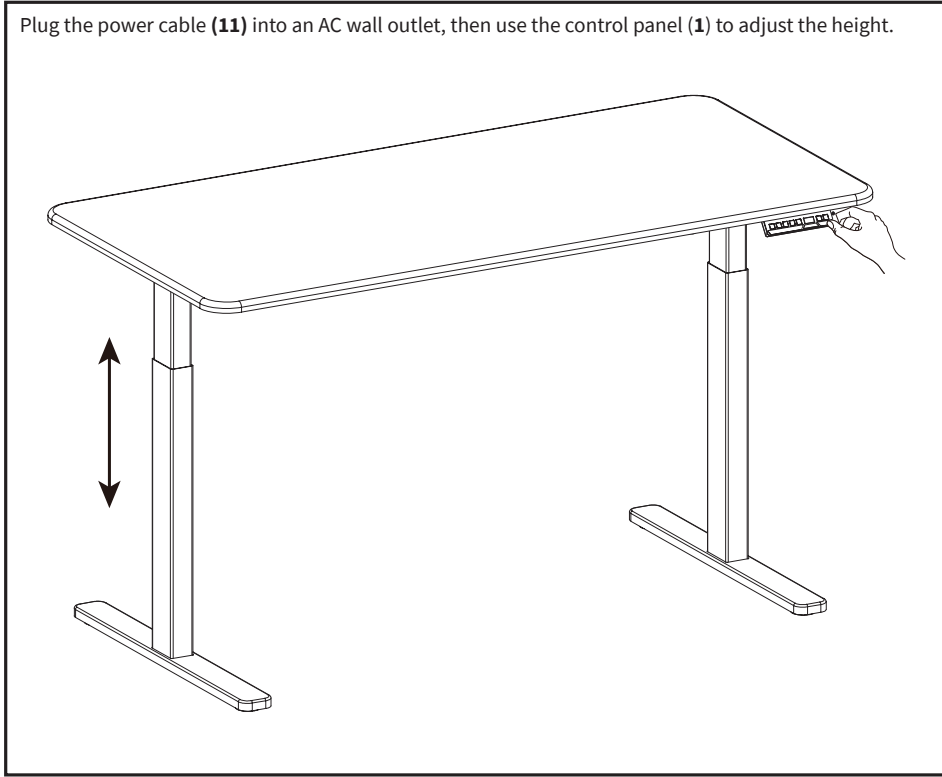

## CAUTION!

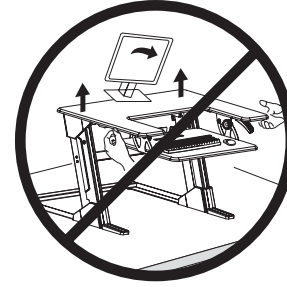

Keep monitor and laptop base fully on the desktop.

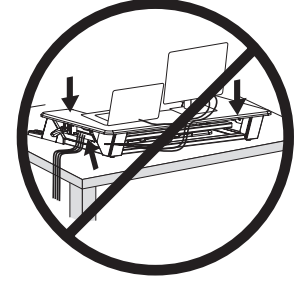

Follow the cable routing instructions to avoid the potential to pinch cables.

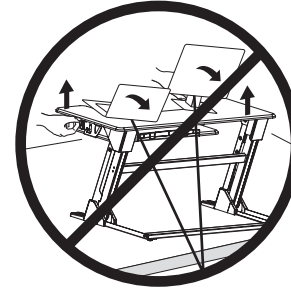

Leave enough slack in cable to allow for full range of vertical motion (15" / 38 cm).



Raise desktop slowly to keep items stable.

Failure to follow these instructions may result in property damage and/or personal injury.



Love your new VIVO setup and want to share?

Tag us in your photo! **@vivo\_us**

Last Updated: 10/19/2018



If any parts are received damaged or defective, please contact us. We are happy to replace parts to ensure you have a fully functioning product.



[help@vivo-us.com](mailto:help@vivo-us.com)



[www.vivo-us.com](http://www.vivo-us.com)



1-800-371-5654

For more VIVO products, check out our website at:  
[www.vivo-us.com](http://www.vivo-us.com).