

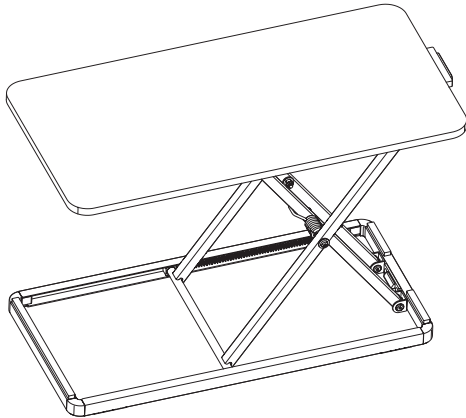

---

## Black Keyboard Riser

Instruction Manual



**SKU: DESK-V024A**



Scan the QR code with your mobile device or follow the link for helpful videos and specifications related to this product.

<https://vivo-us.com/products/desk-v024a>

---

GET IN TOUCH | Monday-Friday from 7:00am-7:00pm CST



help@vivo-us.com



www.vivo-us.com  
*Chat live with an agent!*



309-278-5303

## **WARNING!**

If you do not understand these directions, or if you have any doubts about the safety of the installation, please call a qualified technician. Check carefully to make sure there are no missing or defective parts. Improper installation may cause damage or serious injury. Do not use this product for any purpose that is not explicitly specified in this manual and do not exceed weight capacity. We cannot be liable for damage or injury caused by improper mounting, incorrect assembly, or inappropriate use.

### PACKAGE CONTENTS

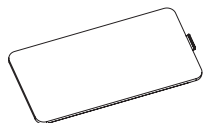

**A (x1)**  
Riser

**DO NOT EXCEED WEIGHT CAPACITY.**

Failure to do so may result in serious injury.



## **WARNING** **PINCH POINT**

DO NOT place hands on or near support bars. Moving parts can crush and cut. Pinch points are created during lifting and lowering the worksurface. Failure to follow these instructions may result in serious personal injury.



## **WARNING: CHOKING HAZARD**

SMALL PARTS - NOT FOR CHILDREN UNDER 3 YEARS. ADULT SUPERVISION IS REQUIRED.

### ASSEMBLY STEPS

#### STEP 1

Carefully remove Riser (**A**) from the packaging and cut the zipties underneath.

*NOTE: Do not press release handle while cutting off zipties. Desk needs to be in the upright position in order to safely depress release handle.*

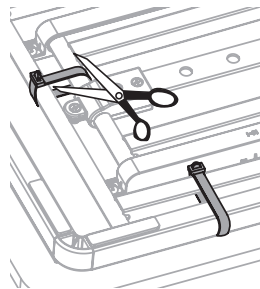
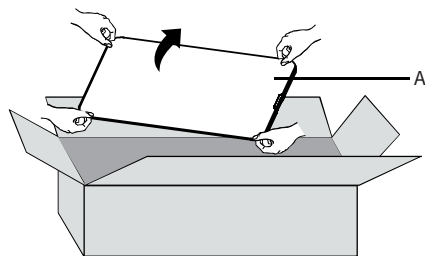

#### STEP 2

Remove the foam insert from the handle and press the handle inward to raise Riser (**A**).

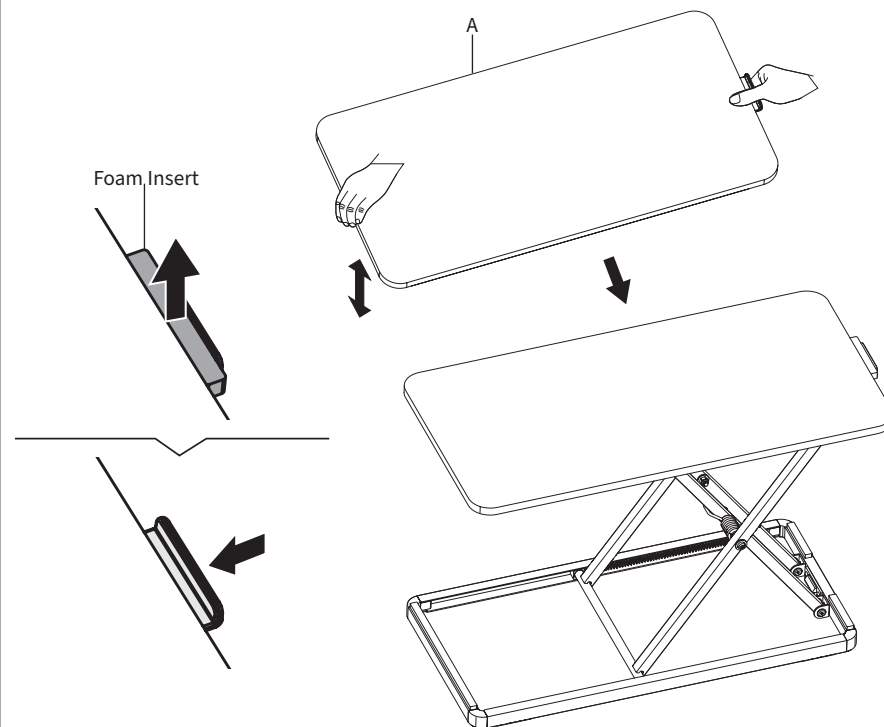

## **CAUTION!**



Keep monitor and laptop base fully on the desktop.

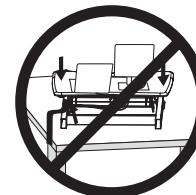

Follow the cable routing instructions to avoid the potential to pinch cables.



Leave enough slack in cable to allow for full range of vertical motion (16.7" / 42.4 cm).



Raise desktop slowly to keep items stable.

Failure to follow these instructions may result in property damage and/or personal injury.

 Love your new VIVO setup and want to share?  
Tag us in your photo! [@vivo\\_us](#)

LAST UPDATED: 11/01/2022  
REV1.1



Open **Monday - Friday 7:00am - 7:00pm** CST,  
our dedicated support team can offer immediate assistance with rapid response times. If any parts are received damaged or defective, please contact us. We are happy to replace parts to ensure you have a fully functioning product.



309-278-5303

**AVG. RESOLUTION TIME** (*within office hrs*): **5M 4S**



[www.vivo-us.com](http://www.vivo-us.com)  
*Chat live with an agent!*

**AVG. RESOLUTION TIME** (*within office hrs*): **< 15 M**



[help@vivo-us.com](mailto:help@vivo-us.com)

**AVG. RESPONSE TIME** (*within office hrs*): **1HR 8M**

- 23% within < 15m
- 38% within < 30m
- 61% within < 1hr
- 83% within < 2hr
- 92% within < 3hr

FOR MORE VIVO PRODUCTS, CHECK OUT OUR WEBSITE AT: [www.vivo-us.com](http://www.vivo-us.com)