

Black Single Top Desk Riser

Instruction Manual

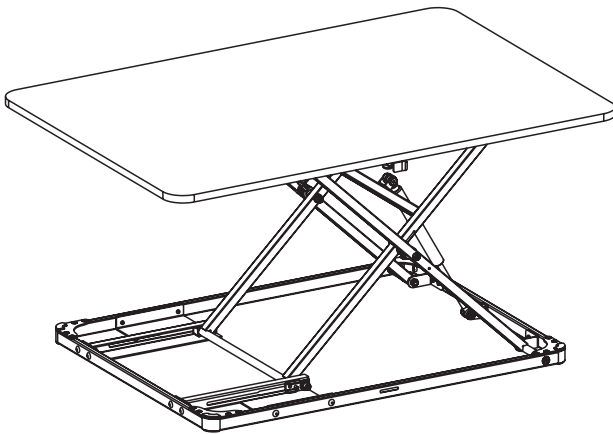

SKU: DESK-V0001



Scan the QR code with your mobile device or follow the link for helpful videos and specifications related to this product.

<https://vivo-us.com/products/desk-v000i>

GET IN TOUCH | Monday-Friday from 7:00am-7:00pm CST



help@vivo-us.com



www.vivo-us.com
Chat live with an agent!



309-278-5303

WARNING!

If you do not understand these directions, or if you have any doubts about the safety of the installation, please call a qualified technician. Check carefully to make sure there are no missing or defective parts. Improper installation may cause damage or serious injury. Do not use this product for any purpose that is not explicitly specified in this manual and do not exceed weight capacity. We cannot be liable for damage or injury caused by improper mounting, incorrect assembly, or inappropriate use.

WARNING: CHOKING HAZARD

SMALL PARTS - NOT FOR CHILDREN UNDER 3 YEARS. ADULT SUPERVISION IS REQUIRED.

PACKAGE CONTENTS

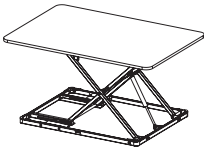

A (x1)
Adjustable
Desk Frame

DO NOT EXCEED WEIGHT CAPACITY.

Failure to do so may result in serious injury.

17.6lbs
(7.98kg)

WARNING **PINCH POINT**

DO NOT place hands on or near support bars. Moving parts can crush and cut. Pinch points are created during lifting and lowering the worksurface. Failure to follow these instructions may result in serious personal injury.



ASSEMBLY STEPS

STEP 1

Carefully remove desk from packaging and set down on a flat surface. Turn the center lock to the open position.

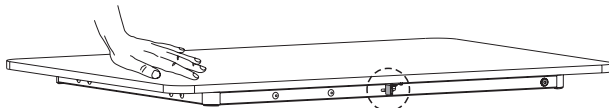
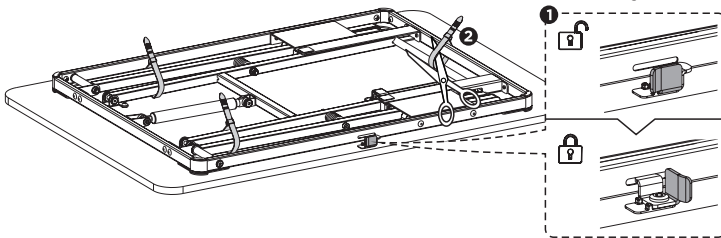

To prevent the desk surface from inadvertently bump causing possible harm, press and hold the surface down prior to releasing the latch.

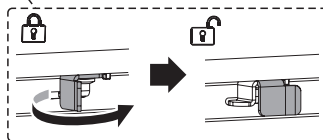

STEP 2

Lift the desktop to the desired height. Remove the Allen wrench from the holder on the bottom of the desktop, and use to tighten lock on rails as shown. This will set the maximum height of the desk. Store Allen wrench in holder when not in use.

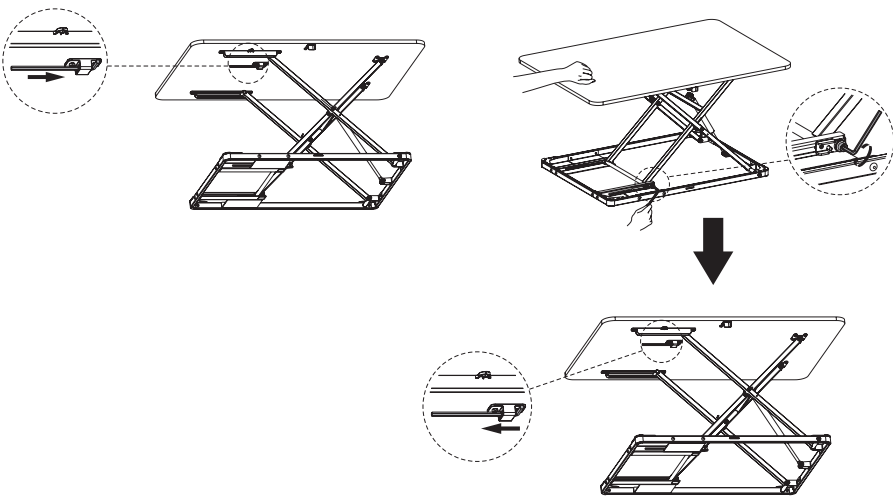

STEP 3

Turn lock clockwise to disengage so desktop may be lowered.

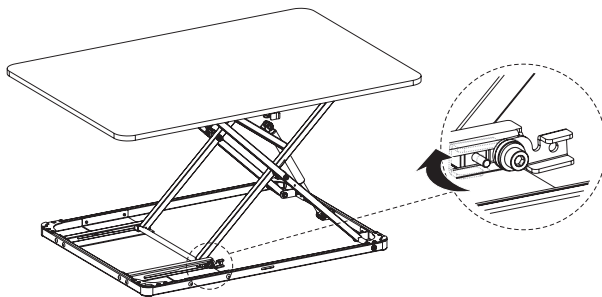

⚠ CAUTION!



Keep monitor and laptop base fully on the desktop.



Follow the cable routing instructions to avoid the potential to pinch cables.



Leave enough slack in cable to allow for full range of vertical motion (15" / 38 cm).



Raise desktop slowly to keep items stable.

Failure to follow these instructions may result in property damage and/or personal injury.

 Love your new VIVO setup and want to share?
Tag us in your photo! **@vivo_us**

LAST UPDATED: 10/08/2020



Open **Monday - Friday 7:00am - 7:00pm** CST,
our dedicated support team can offer immediate assistance with rapid response times. If any parts are received damaged or defective, please contact us. We are happy to replace parts to ensure you have a fully functioning product.

 help@vivo-us.com

AVG. RESPONSE TIME (*within office hrs*): **1HR 8M**

- 23% within < 15m
- 38% within < 30m
- 61% within < 1hr
- 83% within < 2hr
- 92% within < 3hr

 www.vivo-us.com
Chat live with an agent!

AVG. RESOLUTION TIME (*within office hrs*): **< 15 M**

 309-278-5303

AVG. RESOLUTION TIME (*within office hrs*): **5M 4S**

FOR MORE VIVO PRODUCTS, CHECK OUT OUR WEBSITE AT: www.vivo-us.com