

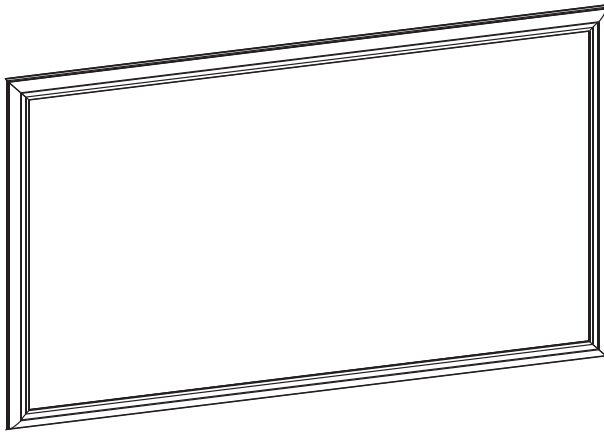

Black Frame Designed for 55" Samsung Frame TVs

Instruction Manual



SKU: COVER-SG55F



Scan the QR code with your mobile device or follow the link for helpful videos and specifications related to this product.

<https://vivo-us.com/products/cover-sg55f>

GET IN TOUCH | Monday-Friday from 7:00am-7:00pm CST



help@vivo-us.com



www.vivo-us.com
Chat live with an agent!



309-278-5303









WARNING!

If you do not understand these directions, or if you have any doubts about the safety of the installation, please call a qualified technician. Check carefully to make sure there are no missing or defective parts. Improper installation may cause damage or serious injury. Do not use this product for any purpose that is not explicitly specified in this manual. Do not exceed weight capacity. We cannot be liable for damage or injury caused by improper mounting, incorrect assembly or inappropriate use.

WARNING: CHOKING HAZARD

SMALL PARTS - NOT FOR CHILDREN UNDER 3 YEARS. ADULT SUPERVISION IS REQUIRED.

PACKAGE CONTENTS

			
A (x1) Top Frame Piece	B (x1) Bottom Frame Piece	C (x2) Side Frame Piece	
			
D (x4) Corner Bracket with Holes	E (x4) Corner Bracket	F (x4) Bottom Latches	G (x2) Upper Hooks
			
S-A (x8) M6x14mm Set Screw	T-A (x1) 3mm Allen Wrench		

ASSEMBLY STEPS

STEP 1

Slide Upper Hooks (**G**) onto Top Frame Piece (**A**) and evenly space Bottom Latches (**F**) onto Bottom Frame Piece (**B**) as shown below.

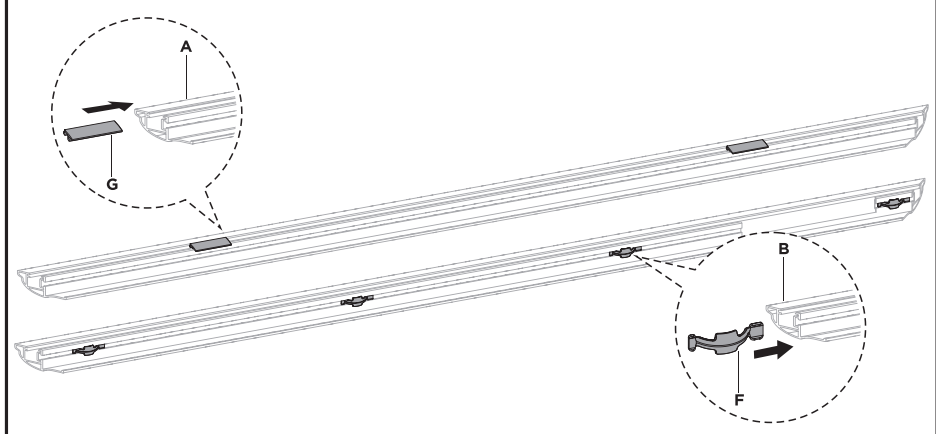

STEP 2

Slide Corner Bracket (**E**) into the bottom track of Top Frame Piece (**A**) and then Corner Bracket with Holes (**D**) into the top track, as shown. Insert Side Frame Pieces (**C**) into Corner Brackets (**E**), then secure by installing M6x14mm Set Screws (**S-A**) into Corner Bracket with Holes (**D**) and 3mm Allen Wrench (**T-A**).

Repeat step for Bottom Frame Piece (B).

NOTE: Once assembled, if you notice gaps on the corners, loosen M6x14mm Set Screws (**S-A**), adjust frame pieces, and re-tighten set screws.

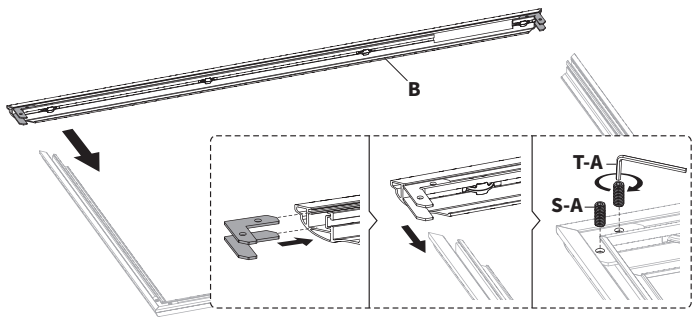
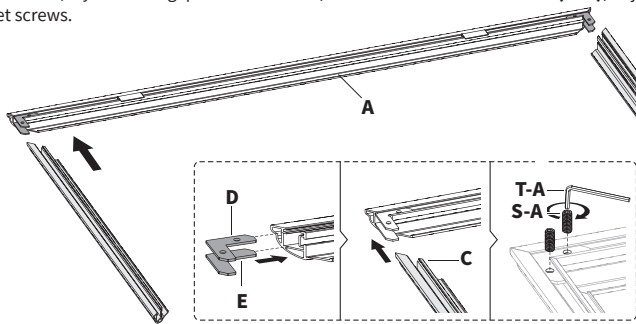

STEP 3

Place assembled frame over top edge of TV at 30° angle so the Upper Hooks (**G**) clip onto the TV. Then push the bottom of the frame to snap into place.

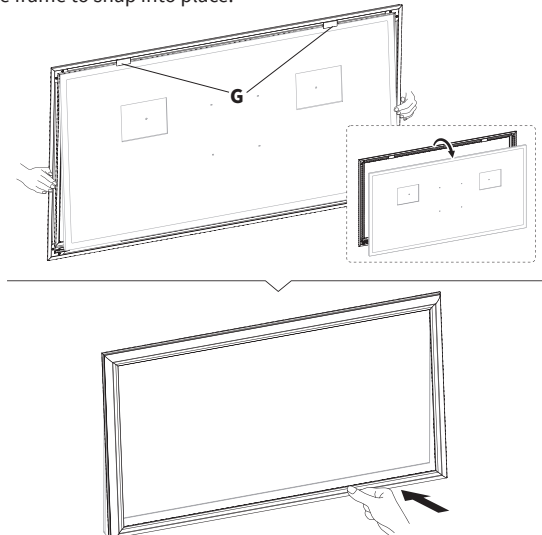



Open **Monday - Friday 7:00am - 7:00pm** CST,
our dedicated support team can offer immediate assistance with rapid response times. If any parts are received damaged or defective, please contact us. We are happy to replace parts to ensure you have a fully functioning product.



309-278-5303

AVG. RESOLUTION TIME (*within office hrs*): **5M 4S**



www.vivo-us.com
Chat live with an agent!

AVG. RESOLUTION TIME (*within office hrs*): **< 15 M**



help@vivo-us.com

AVG. RESPONSE TIME (*within office hrs*): **1HR 8M**

- 23% within < 15m
- 38% within < 30m
- 61% within < 1hr
- 83% within < 2hr
- 92% within < 3hr