

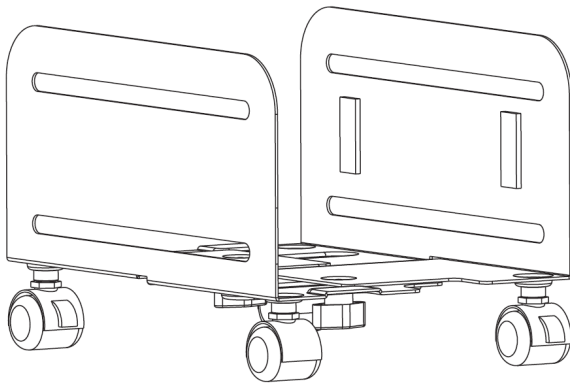

Black CPU Cart

Instruction Manual



SKU: CART-PC01



Scan the QR code with your mobile device or follow the link for helpful videos and specifications related to this product.

<https://vivo-us.com/products/cart-pc01>

GET IN TOUCH | Monday-Friday from 7:00am-7:00pm CST



help@vivo-us.com



www.vivo-us.com
Chat live with an agent!



309-278-5303

WARNING!

If you do not understand these directions, or if you have any doubts about the safety of the installation, please call a qualified technician. Check carefully to make sure there are no missing or defective parts. Improper installation may cause damage or serious injury. Do not use this product for any purpose that is not explicitly specified in this manual. Do not exceed weight capacity. We cannot be liable for damage or injury caused by improper mounting, incorrect assembly or inappropriate use.

TIPOVER WARNING

SERIOUS OR FATAL CRUSHING INJURIES CAN OCCUR FROM TIPOVER. TO HELP PREVENT TIPOVER:

- NEVER ALLOW CHILDREN TO CLIMB, STAND, HANG, OR PLAY ON ANY PART OF CPU CART.
- USE TIPOVER RESTRAINT OR ANCHOR CART TO WALL

USE OF TIPOVER RESTRAINTS MAY ONLY REDUCE, BUT NOT ELIMINATE RISK OF TIPOVER.

WARNING: CHOKING HAZARD

SMALL PARTS - NOT FOR CHILDREN UNDER 3 YEARS. ADULT SUPERVISION IS REQUIRED.

PACKAGE CONTENTS

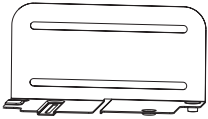

A (x2)
Support Plate



B (x4)
Pad



C (x2)
Knob



D (x2)
Locking Caster



E (x2)
Caster



S-A (x2)
Carriage Bolt

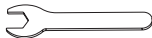

T-A (x1)
Wrench

NOTE: NOT ALL HARDWARE INCLUDED WILL BE USED

DO NOT EXCEED WEIGHT CAPACITY.

Failure to do so may result in serious injury.



ASSEMBLY STEPS

STEP 1

Screw Casters (**D, E**) into Support Plates (**A**). Then tighten casters using Wrench (**T-A**) and apply Pads (**B**) to inner sides of support plates.

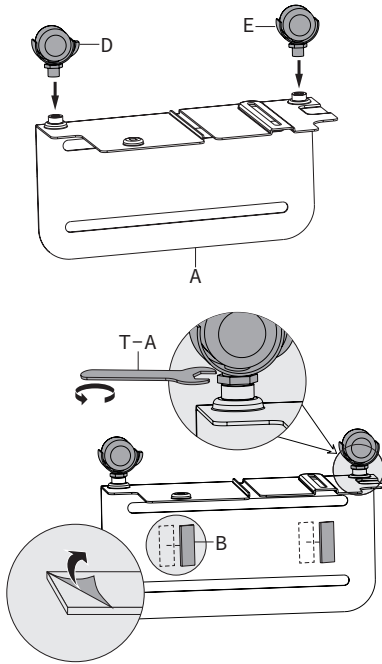

STEP 2

Position Support Plates (**A**) together, insert Carriage Bolts (**S-A**), and secure with Knobs (**C**). Do not yet tighten knobs.

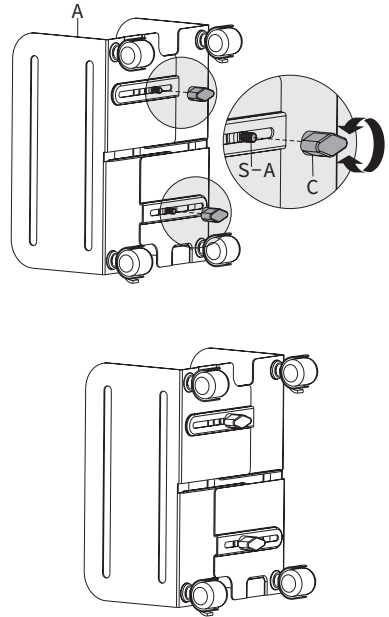

STEP 3

Adjust width of assembled cart to be slightly wider than the computer. The maximum supported width is 8.2" (209mm).

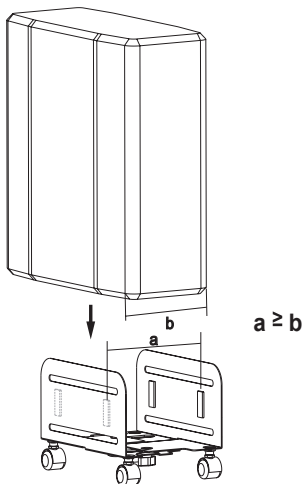

STEP 4

Close sides to secure computer. Then, tighten Knobs (**C**).

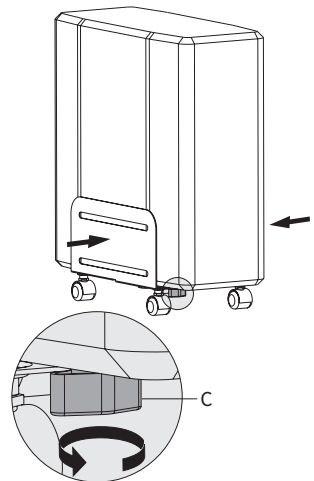



Open **Monday - Friday 7:00am - 7:00pm** CST,
our dedicated support team can offer immediate assistance with rapid response times. If any parts are received damaged or defective, please contact us. We are happy to replace parts to ensure you have a fully functioning product.



309-278-5303

AVG. RESOLUTION TIME (*within office hrs*): **5M 4S**



www.vivo-us.com
Chat live with an agent!

AVG. RESOLUTION TIME (*within office hrs*): **< 15 M**



help@vivo-us.com

AVG. RESPONSE TIME (*within office hrs*): **1HR 8M**

- 23% within < 15m
- 38% within < 30m
- 61% within < 1hr
- 83% within < 2hr
- 92% within < 3hr