

# Electric Commercial Cotton Candy Machine

SKU: CANDY-V001/B

Operating Manual

---

Assembly Video & Product Info  
[www.vivo-us.com/products/candy-v001](http://www.vivo-us.com/products/candy-v001)



# Contact Us First!

***DO NOT RETURN ITEM***

Our friendly product support team is here to help!



PERSONABLE CUSTOMER SUPPORT

**7AM - 7PM**

**Monday-Friday**



Give us a Call:  
**309-278-5303**



Chat Us:  
**[www.vivo-us.com](http://www.vivo-us.com)**



Email Us:  
**[help@vivo-us.com](mailto:help@vivo-us.com)**

---

## We're Here for You!

Our customer-minded support team is here for YOU,  
**Monday-Friday 7am-7pm CST.**  
We offer immediate assistance with rapid response times  
from customer service agents and product technicians to  
help you every step of the way!



## Missing a Part?

If any parts are received damaged / defective OR you are  
missing a part, please reach out to us ***within 30 days of  
product delivery to have it replaced at no cost.***  
We are happy to replace parts to ensure you have a fully  
functioning product



## **WARNING: IMPORTANT SAFETY INFORMATION**

### **READ AND FOLLOW ALL SAFETY REQUIREMENTS**



#### **KEEP THIS MANUAL IN A SAFE AND DRY PLACE FOR FUTURE REFERENCE**

If you do not understand these directions, or if you have any doubts about the safety of the installation, please contact our product support team at 309-278-5303 or help@vivo-us.com for further assistance. Check carefully to make sure there are no missing or defective parts. Improper installation may cause damage or serious injury. Do not use this product for any purpose that is not explicitly specified in this manual. Do not exceed weight capacity. We cannot be liable for damage or injury caused by improper mounting, incorrect assembly or inappropriate use.

- ENSURE THAT SERVICING IS DONE BY PROFESSIONAL SERVICE PERSONNEL, IF APPLICABLE, TO MINIMIZE PRODUCT DAMAGE OR SAFETY ISSUES.
- ALL MINORS MUST BE SUPERVISED WHILE MACHINE IS IN OPERATION.
- THIS APPLIANCE IS NOT INTENDED FOR USE BY PERSONS (INCLUDING CHILDREN) WHOSE PHYSICAL, SENSORY OR MENTAL CAPABILITIES MAY BE DIFFERENT OR REDUCED, OR WHO LACK EXPERIENCE OR KNOWLEDGE, UNLESS SUCH PERSONS RECEIVE SUPERVISION OR TRAINING TO OPERATE THE APPLIANCE BY A PERSON RESPONSIBLE FOR THEIR SAFETY.
- PLUG THE MACHINE INTO AN ELECTRICAL OUTLET WITH A GROUND LINE.



**WARNING:** DO NOT USE IF THE CABLE, ELECTRICAL OUTLET OR PLUG IS BROKEN.



**WARNING:** TO AVOID ELECTRIC SHOCK, DO NOT TOUCH THE PLUG OR ELECTRIC CABLE IF THEY ARE WET. KEEP THE CABLE AWAY FROM HEAT. DON'T IMMERSER THE CABLE, ELECTRICAL PLUG OR THE MACHINE INTO WATER OR OTHER LIQUIDS.



**ATTENTION:** Risque d'incendie et de choc électrique. Remplacez uniquement avec le cordon série du fabricant, une partie No. SJTO (16AWG X 3C)



**WARNING:** DO NOT USE DETERGENT WHEN CLEANING. ANY REMAINING DETERGENT RESIDUE WILL POLLUTE THE CANDY FLOSS. DO NOT LET MACHINE SOAK IN WATER, AS THIS WILL DAMAGE THE ELECTRICAL COMPONENTS.



**CAUTION:** FOLLOW INSTRUCTIONS TO PREVENT BURNS.

- DO NOT TOUCH THE SURFACE OF THE HEATING HEAD WHILE THE MACHINE IS ON.
- DO NOT PLACE HAND INTO THE PAN TO REMOVE THE SUGAR WHILE THE MACHINE IS ON.
- DO NOT MOVE THE MACHINE WHILE IT IS ON.
- ALLOW THE MACHINE TO COOL BEFORE MOVING IT OR REMOVING EXCESS SUGAR.



**CAUTION:** RISK OF FIRE AND ELECTRIC SHOCK. REPLACE ONLY WITH MANUFACTURER'S CORD SET, PART NO. SJTO (18AWG X 3C)



**ATTENTION:** RISQUE D'INCENDIE ET DE CHOC ÉLECTRIQUE. REMPLACEZ UNIQUEMENT AVEC LE CORDON SÉRIE DU FABRICANT, UNE PARTIE NO. SJTO (18AWG X 3C)

## Product Specifications

MODEL	CANDY-V001
DIMENSION	520 x 520 x 415mm
HEATING POWER	1000W
MOTOR POWER	80 W
ELECTRIC VOLTAGE	110V
FREQUENCY	60 Hz
YIELD	1 PER 30 SECOND
FUSE	15A 250V (F15)

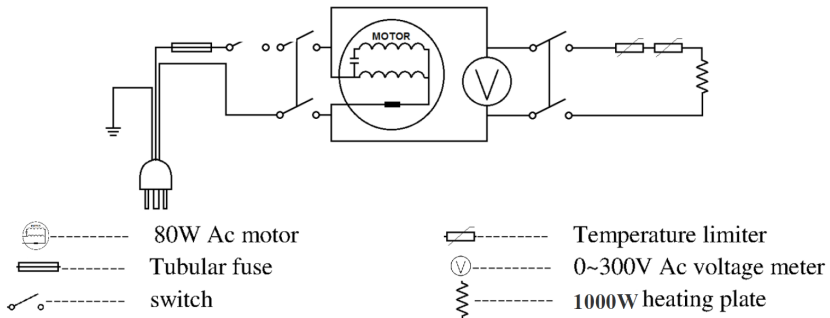

# Prep for First Use

---

## 1. Unpack Components & Inspect

Carefully remove all parts from packaging and set on a dry, flat stable surface. Inspect all parts to ensure no damage has occurred in shipping. Reference contents below.

### Package Contents

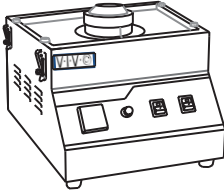

**A(x1)**  
Candy Machine

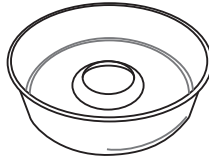

**B(x1)**  
Bowl

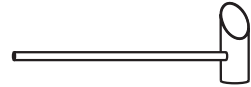

**C(x1)**  
1 Tsp Sugar Scoop



**D(x1)**  
Power Cable



**E(x1)**  
Spare Belt

## 2. Clean Spinner Head & Bowl

Using warm, soapy water, clean the the Spinner Head on the Candy Machine (**A**) and the Bowl (**B**) and rinse thoroughly. Use a soft towel or cloth to dry the entire Bowl. When the machine is first turned on in a future step, the water will clear out from the Spinner Head with the spinning motion.

If needed, the Top Plate on the Spinner Header can be removed for a more thorough cleaning. Please see page 11.



### **WARNING | DO NOT USE DETERGENT CLEANERS**

NEVER use detergent like cleaners to wash ANY components of the Cotton Candy Machine. Doing so will cause harm to the internal parts and prevent proper use.

# Getting Started

## Assembling Candy Machine

Place Bowl **(B)** onto the Candy Machine **(A)** and secure all four Safety Latches to the hooks onto the underside of the bowl.

Plug Power Cable **(D)** into Candy Machine **(A)**.

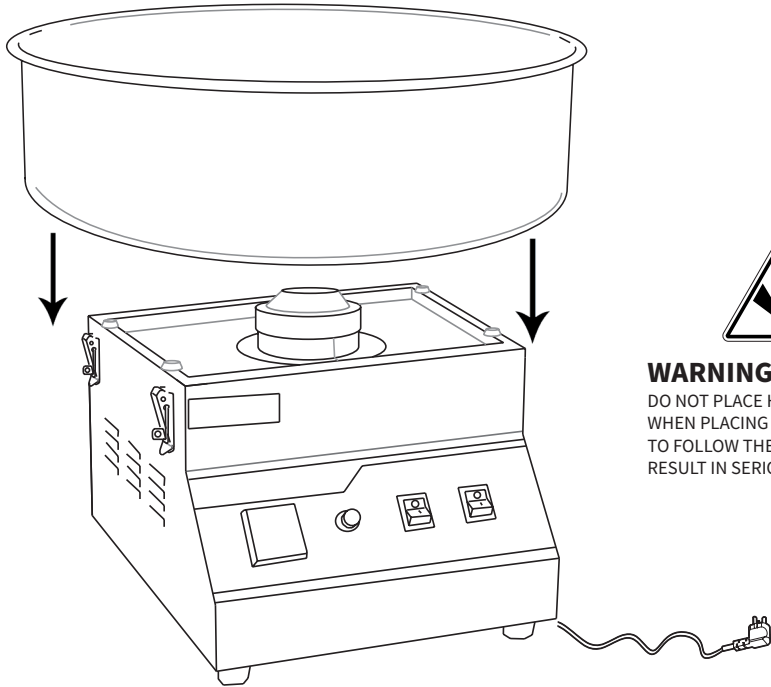

### **WARNING: PINCH POINT**

DO NOT PLACE HANDS UNDER BOWL WHEN PLACING ON MACHINE. FAILURE TO FOLLOW THESE INSTRUCTIONS MAY RESULT IN SERIOUS PERSONAL INJURY.

### **Secure ALL Safety Latches**

**NOTE: Candy Machine WILL NOT power if the Safety Latches are not secured properly.**

The Candy Machine has a built-in Safety Switch, which prevents the machine from powering on if the Bowl is not properly secured by the **Safety Latches**.

Ensure Bowl is in place and secure all Safety Latches. When plugged in, the front power switches will illuminate red.

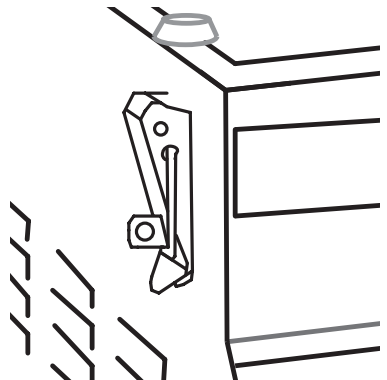

## Powering On for the First Time

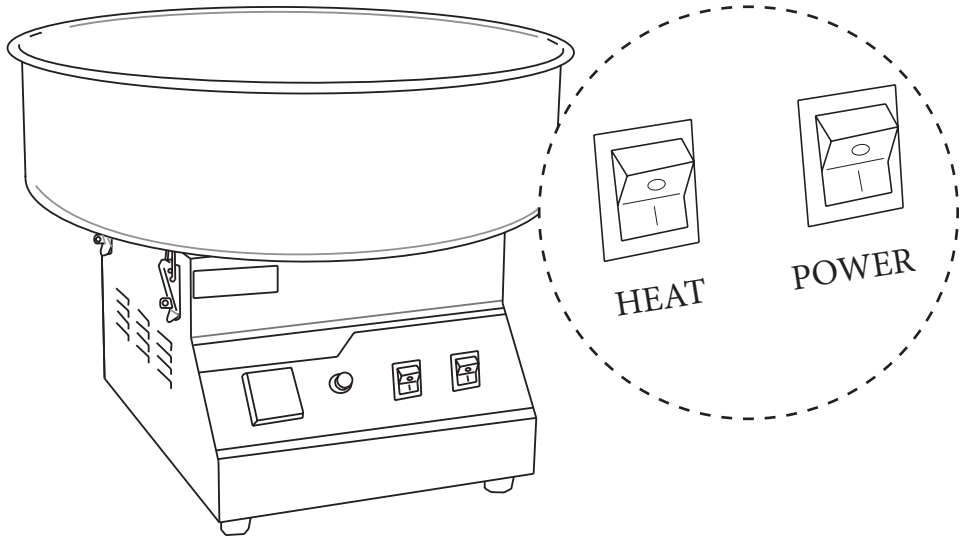

### Power On

Turn on the **Power Switch**. Let the machine run for 1-2 minutes to allow the motor and drive belt to warm up for best performance. **DO NOT** turn heat on until the motor has time to warm up.

### Heating Up

After the motor has warmed up, turn on the heating switch and allow the head to warm up for 4-5 minutes.

**PLEASE NOTE:**

The machine may vibrate while running; this is normal and will not affect operation.

# Creating First Candy Floss

## **1. Pour One Scoop of Sugar**

After heating, pour one scoop full of sugar into the center of the heating head.

**If using hard candy**, turn off machine and place hard candy pieces evenly in the center of the heating head. Break up into smaller pieces to fit if necessary. Turn machine back on.

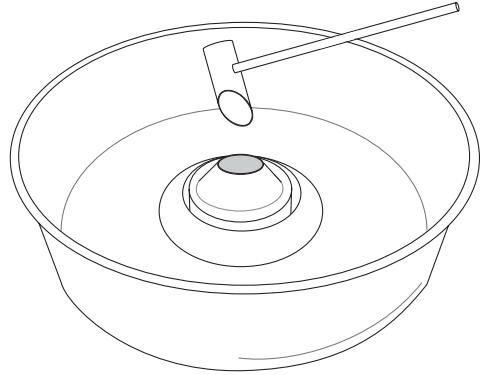

### **Recommended Candy Types:**

For a detailed list of candy types to use and avoid, please see page 10.

## **2. Collect Candy Floss**

The candy floss will form after roughly 30 seconds.

Use a paper cone, candy stick, or other related object to collect the candy floss. Revolve the object in a circular motion following the bowl. Turn the object sideways directly over the heating head and continue twisting the object in order to collect the floss into a ball shape.

To continue making candy floss, repeat steps.

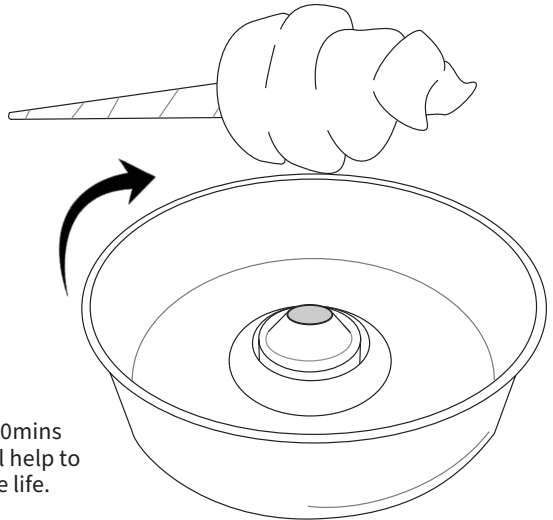

### **POWER OFF AFTER 1HR:**

Unit should be powered off for at least 20mins after one hour of continuous use. This will help to prevent overheating and prolong service life.



### **3. Clean After 20mins of Continuous Use**

To prolong the use of the machine, the machine should ALWAYS be cleaned for proper function. Failure to do so may cause burning of floss and will also void the spinner head warranty.

#### **Add Water to Spinner Head**

With the machine still hot and running, slowly pour a small amount of water in to the center of the Spinner Head.



#### **USE WITH CAUTION:**

Water will immediately become steam.

#### **Allow Head to Spin**

Keep water spinning through until color inside is cleaned to the bare aluminum again.

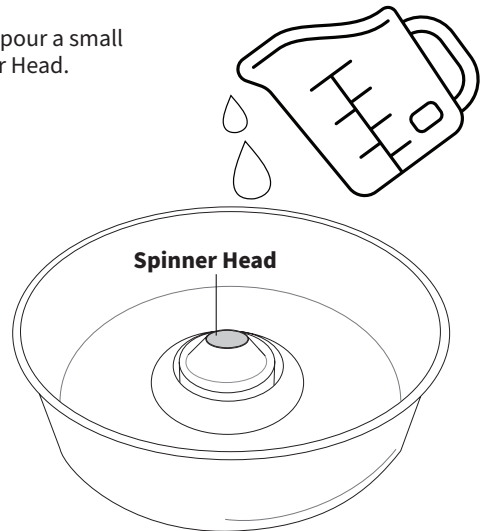

#### **Power Off Machine**

Power off the machine by flipping both switches and allow the motor to cool. After 10mins, wipe down head with a damp cloth to clean off excess sugar.

Once cool and cleaned off, proceed with your next round of cotton candy making.

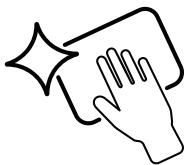

**For further cleaning instructions, please see page 11.**



## Recommended Cotton Candy Sugars



### Hard Candies:

- **Life-Savers® Hard Candy**
- **Claeys®**
- **Jolly Ranchers®**
- **Generic Fruit Discs/Buttons**
- **Brach's® & Starlight® Mint Hard Candy**
- **Lemon Candy**  
*ex: Lemon Heads®*
- **Artificially Flavored Butterscotch, Cinnamon, Root Beer & other flavored Hard Candy**
- **Candy Canes, Sticks & Suckers**  
*Note: Must be broken or crushed up*

**\*\* Please Note \*\***

*Hard candy typically requires more frequent cleaning of the machine due to lower burn temperatures of the ingredients.*



### Sugars:

- **White-Sugar Based Flavored Sugars**  
*ex: Gold Medal®, Cotton Candy Express®, The Candery®, Nostalgia®, etc*
- **White Sugar**
- **Organic White-Sugar Based Cotton Candy Sugars**
- **Maple Sugar**  
*Note: May require more frequent cleaning*



## Sugars/Candies to AVOID

- **Naturally-Flavored Butterscotch/ Butter Rum Hard Candy**  
*ex: Werthers®, Life-Savers®, etc.*
- **Coffee Hard Candy**
- **Soft or Gummy Candies**
- **Soft-Centered Candies**  
*ex: Strawberry Bon Bons, Tootsie Pops, etc*
- **Creme Savers®**
- **Confectioners Powdered Sugar**
- **Brown Sugar**
- **Powdery Hard Candies**  
*Breath Mints, Smarties®, Pixie Sticks®, Necco® Wafers, Sweethearts®, etc.*
- **Chocolate**
- **Isomalt-Based Sugar-Free Candy**
- **Nerds® Candy**
- **Life-Savers® Mints**

# Cleaning & Caring for Unit

## Cleaning & Removing Spinner Head Top Plate

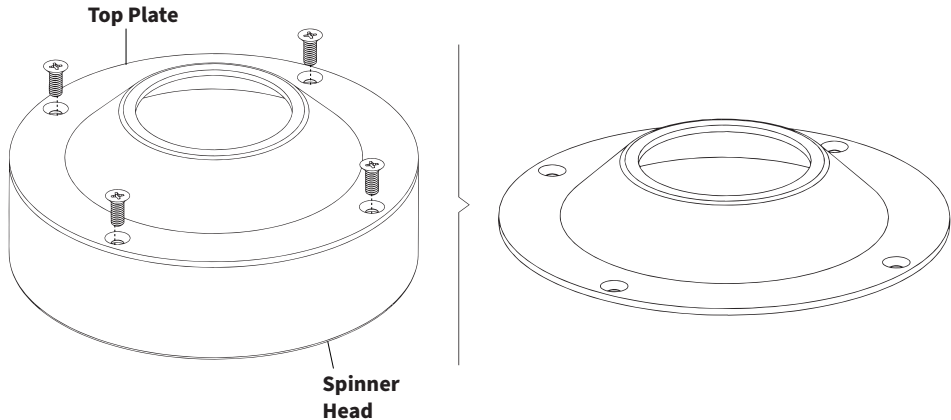

### 1. Remove Top Plate:

Separate the **Top Plate** from the **Spinner Head** by removing the four screws on the top. Gently pull **Top Plate** off.

If screws are difficult to remove, turn on the machine and heater for 15-20 seconds to free up the screws.

### 2. Clean Head & Reinstall

Clean the Top Plate with dish soap and warm water. Dry completely and reinstall, making sure not to overtighten screws. There should be a thin gap between the Top Plate and the Spinner Head Base, allowing only a piece of paper to pass through.

### 3. Return to Candy Making

Allow machine to heat back up for 4-5 minutes before making more candy floss. This will help the machine run well and require only minimal cleaning after each use.



#### **WARNING**

#### **DO NOT USE DETERGENT CLEANERS**

NEVER use detergent like cleaners to wash ANY components of the Cotton Candy Machine. Doing so will cause harm to the internal parts and prevent proper use.

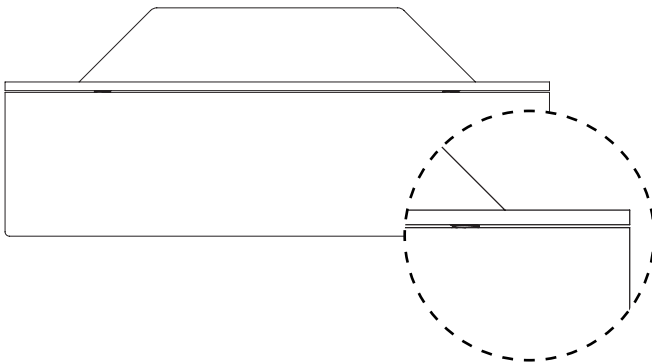

# Further Maintenance

---

## Step-By-Step Maintenance Videos

For further maintenance and care of your cotton candy machine, scan the QR code to access step-by-step videos on standard maintenance to keep your machine working properly.



### Topics Covered

#### **How to Remove Burnt Sugar**

Due to the nature of sugar, it is normal for a small amount to burn inside even with periodic cleanings. This will not harm the machine or candy floss produced. Follow this video for instructions for removal of build up.

#### **Belt Replacement**

In the event that the belt fails or encounters wear, a Spare Belt (**E**) is provided. Follow along with this video for easy removal and replacement.

# Troubleshooting

---

## Product Warranty

We offer a ONE YEAR warranty for this product. If you have any problems with the machine, please contact us directly. We have a 30 Day Return Policy.

Problem	Solution
Heating Head Spins but does not Heat Up	Ensure wires underneath heating head are not cut or frayed, and that the heater switch is lighting up. If wires are not damaged then the temperature sensor may be out.
Machine has No Power	<p>Bowl may not be secured to machine (all four latches should activate the safety switch). If safety switch is pressed and switches are on, check if red light is illuminating from switches.</p> <p>Please contact us at 309-278-5303 or <a href="mailto:help@vivo-us.com">help@vivo-us.com</a> for further assistance if it is still not working.</p>
Electric Cord for Machine is Lost	<p>Electrical Cord can be replaced using any standard C13 Power Cord, which are typically available for printers, computers, etc. Ensure it is rated 20 AMPS.</p> <p>As a note, cotton candy machine is designed to run on US 110V power.</p>
Machine Vibrates Excessively	Head/spinner is off balance. Please contact us at 309-278-5303 or <a href="mailto:help@vivo-us.com">help@vivo-us.com</a> for a replacement.
Heating Head not Turning, Motor Running	Ensure belt inside machine has not come loose. If belt has come loose, reinstall in machine and adjust the belt tension by loosening the 4 motor screws and repositioning the motor slightly. If belt is broken, replace using enclosed Spare Belt.

## CHECK OUT OTHER GREAT PRODUCTS FROM



### EXPLORE MORE AT [VIVO-US.COM](https://www.vivo-us.com)

*We offer a wide array of home & office products to fit your needs. From height adjustable desks to monitor mounts to keyboard trays and more!*

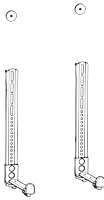

#### **SPEAKER MOUNTS & STANDS**

Whether you're mounting a soundbar or surround sound system, we've got a mounting solution to fit your needs

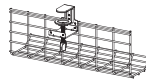

#### **CABLE MANAGEMENT**

From single monitor mounts to hex mount, grommet or clamp-ons, we've got a mounting solution for your setup.

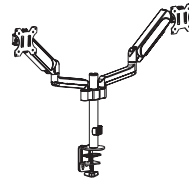

#### **MONITOR MOUNTS**

From single monitor mounts to hex mount, grommet or clamp-ons, we've got a mounting solution for your setup.



## WHO WE ARE

---



VIVO is more than a brand of ergonomic office furniture. We are a team of creative and innovative individuals working together to offer high quality, affordable ergonomic solutions. We think and work outside of the box to serve you, our customer, to the best of our ability.

*\*Some minor graphics featured in this manual provided by Noun Project Creators*



# Need Assistance?

We Would Love to Help!



## Personable Customer Support | **Mon-Fri 7am-7pm**

We offer immediate assistance with rapid response times from customer service agents and product technicians to help you every step of the way!

---



Call Us: **309-278-5303**

Average Resolution Time: **5m 4s**



Chat Us: **[www.vivo-us.com](http://www.vivo-us.com)**

Average Resolution Time: **< 15m**



Email Us: **[help@vivo-us.com](mailto:help@vivo-us.com)**

Average Resolution Time: **1HR 8M**

*23% within < 15m*

*38% within < 30m*

*61% within < 1hr*

*83% within < 2hr*

*92% within < 3hr*



## Need Help? Get In Touch

Monday-Friday from 7:00am-7:00pm CST



[help@vivo-us.com](mailto:help@vivo-us.com)



[www.vivo-us.com](http://www.vivo-us.com)

*Chat live with an agent!*



309-278-5303



**VIVO-us** @vivo\_us

FOR MORE GREAT VIVO PRODUCTS,  
CHECK OUT OUR WEBSITE AT: [WWW.VIVO-US.COM](http://WWW.VIVO-US.COM)