

Barista T
2021

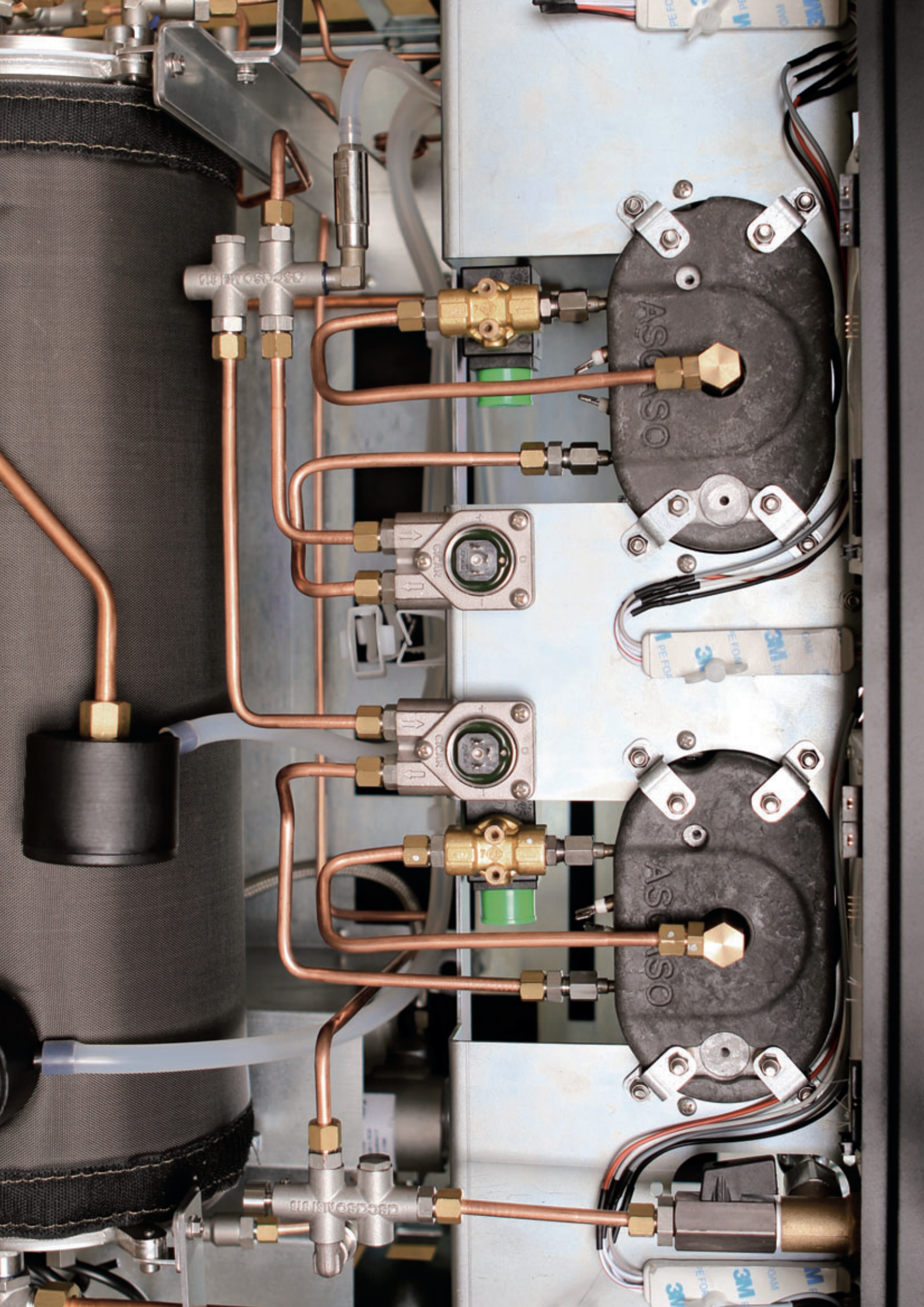

ascaso
BARCELONA



BARISTA T

A product incorporating latest-generation technology. Multi-group. Complete PID control. Highly energy efficient. A range of very competitive, top-quality technologically advanced coffee machines.

After the creation of our Big Dream model, in which we have changed a technical criterion used for more than 100 years (using stainless steel instead of copper and brass), we wanted to continue creating unique products. A product that would also mark a turning point in the industry.



Multi-group
(separate) technology with PID control. High professional-grade performance: Thermal stability guaranteed (in continuous or intermittent use). High steam production (separate, high-volume boiler).



Clean coffee. Minimal metal migration to the beverage through the use of stainless steel.

EN16889
NICKEL (NI) <0.14 MG/KG
LEAD (PB) <0.01 MG/KG

Complies with European regulation EN 16889



Freshly Delivered Water. Avoiding the use of standing, constantly reheated water to make the coffee. Without affecting the water's oxygen content, preserving its completeness and improving the coffee's taste.

The water for each coffee comes directly from the mains supply, taking fresh, filtered water to the group.



Energy efficiency. One of the T Technology's key goals was to reduce the machine's energy consumption. It had to be a sustainable product. Improving on what was available. And we've done it. We deliver a 50% average saving compared with a traditional machine and 25% compared with other multiboiler machines.



T TECHNOLOGY

A cleaner, more stable and sustainable water management.

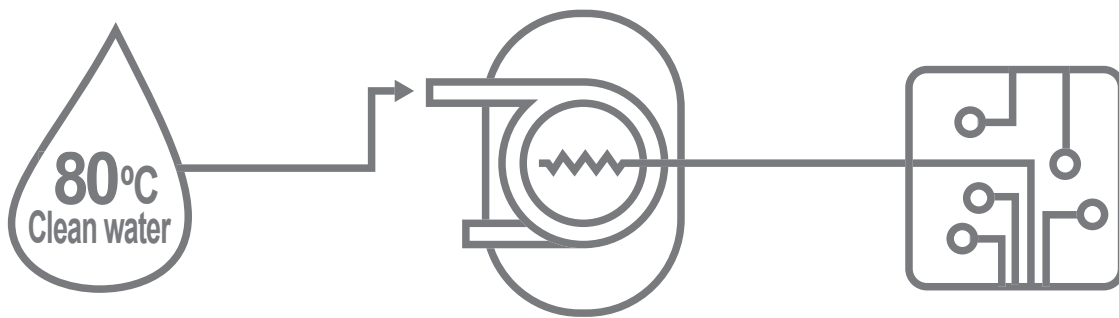

PREHEATING SYSTEM

We preheat the fresh water we use in each coffee.

THERMODYNAMIC GROUP

With PID control, double heating element and thermal covers. Maximum stability.

SOFTWARE (algorithm Pid)

Maintains thermal stability throughout the system. We do not offer a fixed temperature in each group, the temperature is adapted to the working conditions (high frequency of services or widely spaced).



Thermodynamic coffee group

A REAPPRAISAL OF TRADITION. SUSTAINABLE ENGINEERING.

From E-61 technology to T

First, society changes. Neither manufacturers nor engineers nor industrial engineers invent new needs. It is society that demands products that are more sustainable with improved energy efficiency, easier to use and longer-lasting.

In these new times, it is the professional barista who demands innovative products without compromising the espresso's

At Ascaso, our team of engineers has spent years working to differentiate and perfect our espresso coffee machines. And this has led us to reappraise our approach to tradition. To ground our projects on sustainable engineering.

In the '60s, the development of the E-61 group brought innovation to the espresso world. It was an instant success and became one of the most widely used systems in the history of espresso coffee. Even today, many manufacturers still use it or work with its principles.

But, almost 60 years later, we needed to look for a new technology that addressed the shortcomings of the old.



for coffee lovers

water

97

00



1 short

1 large

2 short

2 large

for coffee lovers





for coffee lovers

for coffee lovers

for coffee lovers

for coffee lovers

for coffee lovers

0

97

000



extralarge

1 short

1 large

2 short

2 large

extralarge

ascaso
for coffee lovers



SUSTAINABLE
ENGINEERING
thinking green

ascaso

BARISTA T ZERO



2GR Black Compact (56cm)



2GR Black or White



Barsita T 3GR Black



2GR B&W Compact (56cm)



2GR Black&Wood



3GR Black&Wood



2GR White&Wood

BARISTA T ONE



2GR Black or White



Barsita T 3GR Black



2GR Black&Wood



3GR Black&Wood



2GR White&Wood

BARISTA T PLUS



2GR Full Inox



3GR Full Inox



2GR B&W Compact (56cm)



2GR Black&Wood



3GR Black&Wood



2GR W&W Compact (56cm)



2GR White&Wood



3GR White&Wood

MODELS BY SIZES



2G Compact (56cm)
Only mod. Zero and Plus



2G



3G

Main features

- Multi Group technology (on/off by group). Professional Thermodynamic Groups.
- Independent steam boiler. Stainless steel Aisi 316. Extremely sturdy. Large capacity.
- Independent and regulable electronic temperature control for each group.
- External Pid control (0,1°C) for each group and steam boiler.
- External timer for each group.
- Digital Display in each group. Multiple functions. Total control.
- Thermal lagging on steam boiler and groups.
- Thermal stability (+/- 0.5°C).
- Dynamic preheating (coffee groups).
- Energy efficient (-50%).
- High performance volumetric pump. Constant pressure even after a prolonged and simultaneous use of more groups
- Powerful steamer (12 mm anti-lime scale tube. Stainless Steel. Cool touch).
- High-precision filters in AISI 304 stainless steel.
- Active cup warmer. **(Plus model)**
- Designed for baristas: joystick steam controls, LED in work area, 5 volume selections, Pid controls...
- Different colours and customization options.

BARISTA T ZERO

Black or White



Wood option



2 GR Compact (56cm)



2 GR (70cm)



BARISTA T ONE

Black or White



ascaso
BARCELONA

BARISTA T ONE

Black & Wood



ascaso
BARCELONA

BARISTA T ONE

White & Wood



ascaso
BARCELONA

BARISTA T PLUS

inox



ascaso
BARCELONA

BARISTA T PLUS

Black & Wood



2 GR Compact (56cm)



2 GR (70cm)



ascaso
BARCELONA

BARISTA T PLUS

White & Wood



2 GR Compact (56cm)



2 GR (70cm)



ascaso
BARCELONA

BARISTA T PLUS

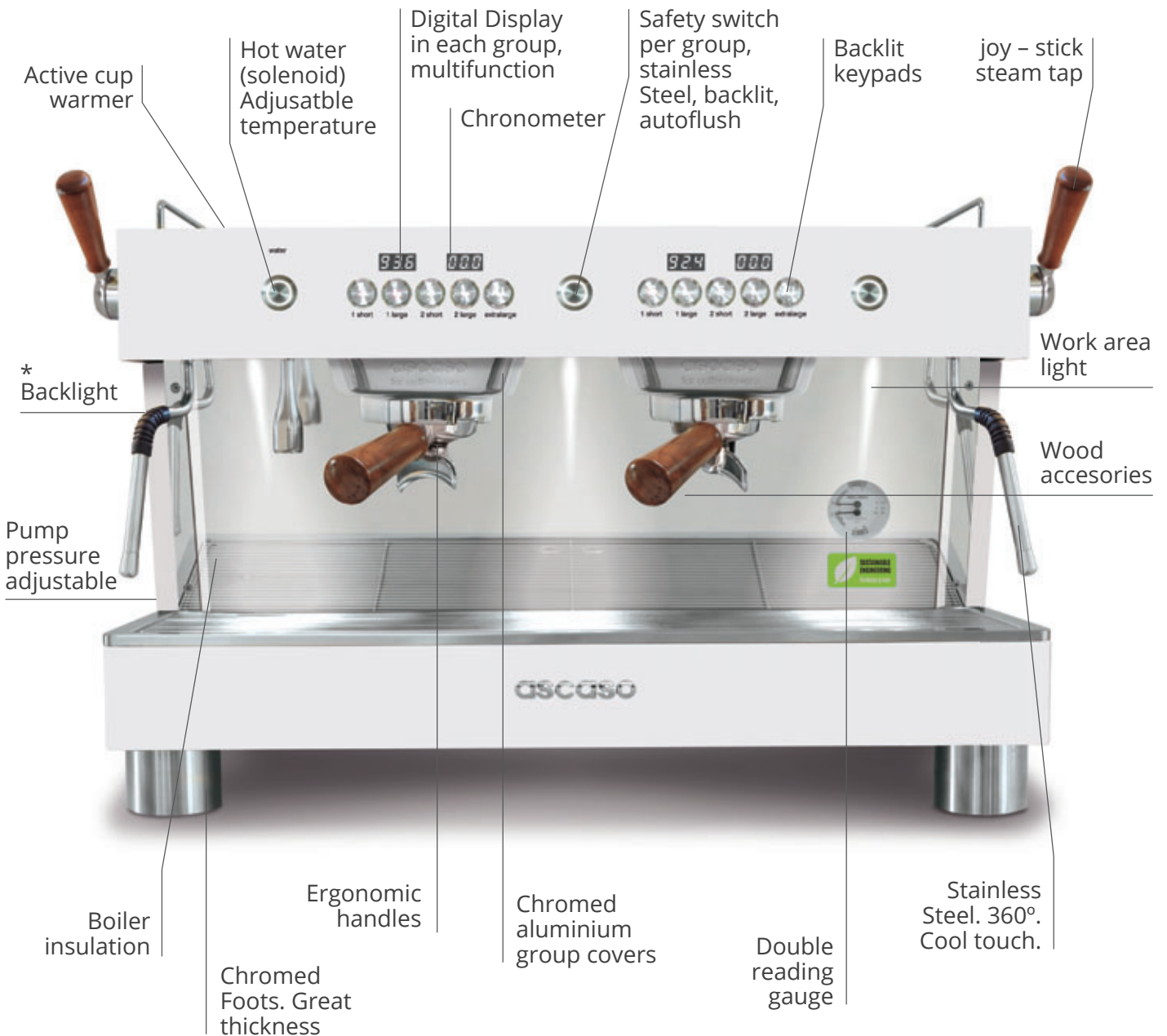

DESIGN



- **Work area light.**
(on/off switch)

- **Steam and water wands.**

Stainless steel. Multidirectional to 360°. The steam wand is anti-lime scale and remains cool to the touch, reducing the risk of contact burns. Milk build-up is reduced to a minimum, making for easy cleaning.



- **Steam outlets.** Special design. The rounded edges, the smooth lines and four tangential outlets all mean creamy coffee every time.



4 outlets
1,2mm (1,6mm optional).

- **Steam/water knobs.**

Over-sized, innovative shape with a pleasant feel. Non-slip grip.



Wood option

- **JOY-STICK**

The stick facilitates use and improves control. A smooth, intuitive 'natural' movement makes it easy to use and control.



- **Inox tray.**

Easy to clean with thin wire tray so as not to dirty the bottoms of the cups.



DESIGN

■ Ergonomic filter holder handle.

Thanks to its ergonomic design, it has a strong yet pleasant feel. Non-slip grip handle. It is tilted 10° for ease of use, while the horizontal placement of the filter holder in the delivery group ensures perfectly pressed coffee grounds.

BARISTA T ONE



BARISTA T PLUS



The filter holder is one of the most heavily used parts of the machine. It is important that the design facilitates the barista's work.

We focused on various aspects of the handle:

Designed to adapt to the palm of the hand, conveying a pleasant sense of strength and safety in use.

The 10° tilt facilitates its use, allowing the hand to adopt a natural position.

Horizontal resting position of the filter holder for perfect tamping of the ground coffee.

Coffee spouts. Thanks to the closing system these are always positioned centrally, making assembly and dismantling safe and easy.

■ Back-lit button pad.

5 options. Automatic cleaning cycle.



■ Cup warmer. Plus model.

(on/off switch)
Accessory that guarantees electric cup warming, with a direct heat source (minimum consumption: 50 W).

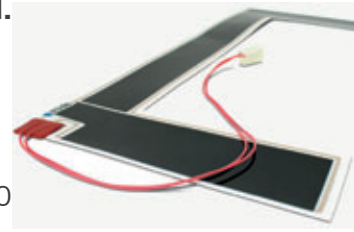

■ Gicar flowmeter (protected).



■ **R.P.M. motors.** High quality and power. (150W-1gr / 165W-2gr / 265W-3gr). Internal.



■ 3 ways solenoid

Perfect dry doses.
No leaking.
No over pressure.
Made of unleaded brass + stainless steel AISI316.



■ High-precision pressure gauge.

Double reading gauge. It allows to the boiler and the pump pressure.



■ Professional aluminium tamper.



SAFETY

- ✓ Static relay or contactor.
- ✓ High-quality heat-resistant wiring.
- ✓ Electronic boiler water level.
- ✓ Safety thermostat if the boiler is empty.
- ✓ Tap to empty boiler.
- ✓ High-quality components

TECHNOLOGY

STAINLESS STEEL: A REMARKABLE MATERIAL

■ Energy & Efficient

We guarantee a saving 50% compared to a single boiler traditional coffee machine.

- Use of electronically controlled thermodynamic coffee groups (instead of boilers or systems with repeatedly heated water). Focused on conserving energy by heating the extraction water only.
- **Electronic temperature management.** Computer software and high-precision sensors that manage the system automatically. The heating element only operates when necessary and only for as long as required. It allows 'smart' control, with a much lower energy consumption than other systems on the market.
- **PID Control** in all the coffee boilers and the steam boiler. All the boilers are controlled by a PID system, featuring electronic thermostats that are much more precise and act much faster than the traditional mechanical pressure gauge system.
- The **Multi-Group System** means that power is only used by the part of the machine in use at any time. Each group can be turned off or on independently. If the group is turned off, it reaches operating temperature in 1 minute.
- **Thermal lagging** made from high-tech material for coffee and steam boilers. Thermal lagging notably increases the quality of the coffee machine and the energy-efficient. Unit is thermally insulated from the rest of the machine.

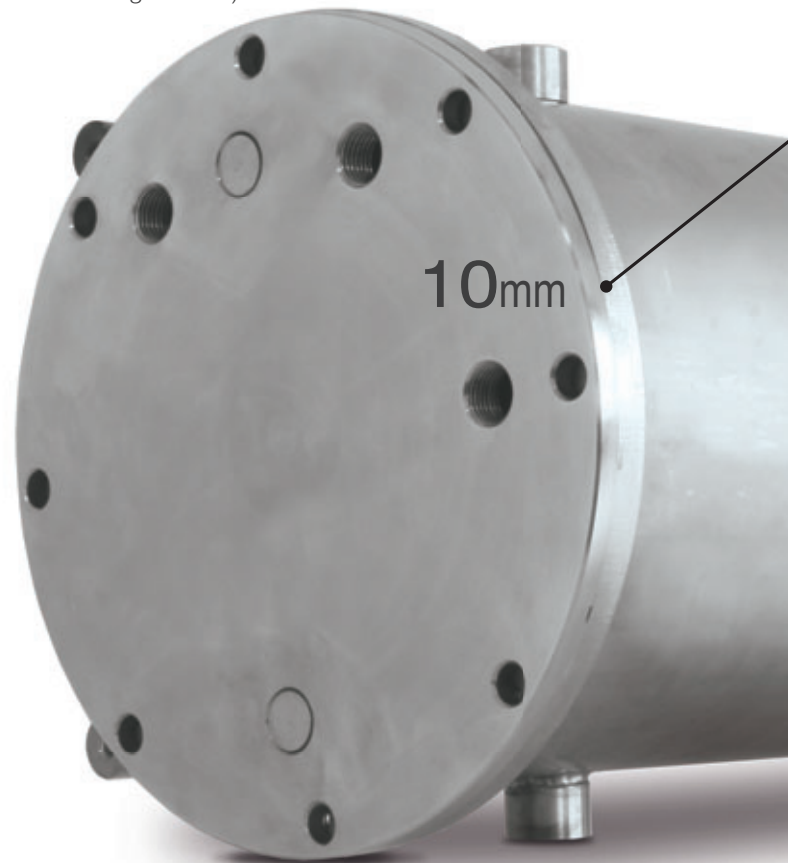
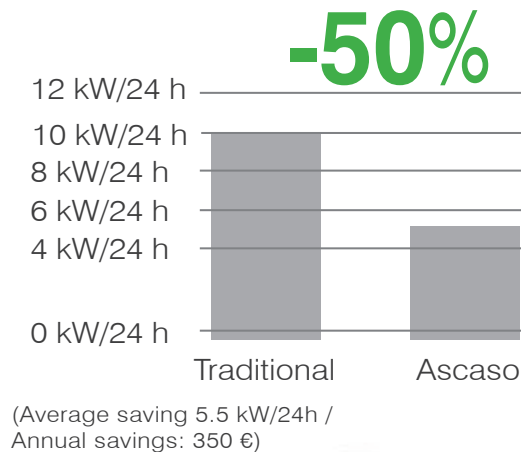

Stainless steel AISI316 fittings

TECHNOLOGY



AISI316 Plasma weldings



Inox AISI316 rotary pump

High-quality Incoloy®800 stainless steel heating element

■ Mechanical resistance

The mechanical resistance of copper is almost nil. Stainless steel has a high mechanical resistance.

■ Anti-limescale

Stainless steel is the ideal material to avoid the build-up of lime scale deposits.

Filter holder after 115,000 services (35° water hardness)

Lime adheres to the brass.



■ 100% FOOD-SAFE

Its offers optimal corrosion resistance. It is an excellent choice from a hygiene point of view.

EN16889
NICKEL (NI) <0.14 MG/KG
LEAD (PB) <0.01 MG/KG

TECHNOLOGY

Multi-Group System

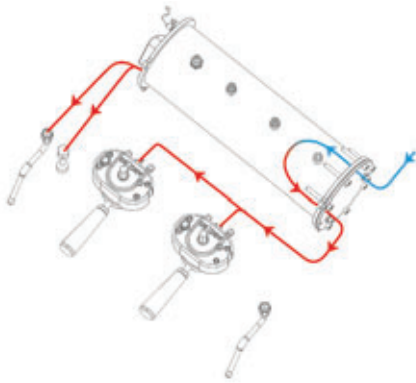

The multi-group technology is based on coffee groups and a steam boiler that work completely independently. Each group and boiler have their own autonomous heating system, safety device and precise electronic temperature control.

Advantages

- Aids energy saving.
- You can turn a group on or off independently.
- Standby function by group or for all the groups. Being independent, the power is only used for the parts of the machine you are using at that particular time.
- Excellent thermal stability.
- Excellent extraction quality for either small or large operating volumes. The quantity of steam does not influence the thermal stability of the coffee groups.
- High, consistent steam production (exclusive boiler)
- The machine can be adjusted to different types of coffees and roasts.
- Extra safety level. If there is a problem with one group, the others will continue working.

PID Control

(PID) (Proportional Integral Derivative)

Easy and optimal temperature regulation lets you select the appropriate extraction process for each coffee, producing excellent results.

Our system offers a precision of 0.5°C which considerably reduces any heat fluctuations within the coffee group. The barista simply has to select the desired temperature and Barista T will do the rest.



To do so, Barista T has triple temperature control:

1. Pre-heating/temperature of the water entering the coffee group.

2. Control of the temperature of each coffee group (PID).

Each group is completely independent and easy to control by the general or individual display (precision of 0.1°C).



3. Control of the steam boiler/water temperature (PID)

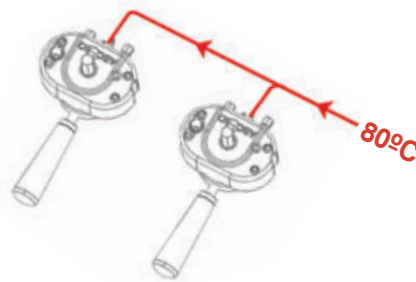
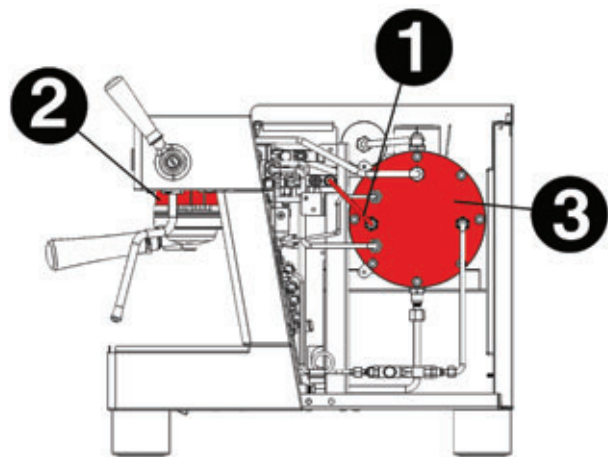

TECHNOLOGY

Professional coffee group

New Thermodynamic Coffee Groups.

With a large thermal mass (lead free brass), heated with a separate professional-grade thermoblock (modern thermodynamic technology) in each group, with a temperature sensor that can be easily adjusted by the barista.

With thermal insulation on all surfaces. Focused on conserving energy by heating the extraction water only. The coffee group is completely 'enveloped' by thermal cladding. Unique in the market.

Thermal stability. Energy efficiency.
1, 2 or 3 groups independent of each other and independent of the steam production steam and water boiler.



- **Clean water.** Here it is constantly renewed and clean for every coffee. As the water does not stand in the boiler, being constantly re-heated, quality is not affected.
- **Thermal stability.** Quality in cup. Thanks to its high capacity and internal pipe measuring over a metre long. Optimised with electronic temperature control.
- **100% food-safe.** AISI 316 stainless steel water circuit.
- **Less limescale build-up.** Easy-to-clean stainless steel circuit reduces limescale build-up.

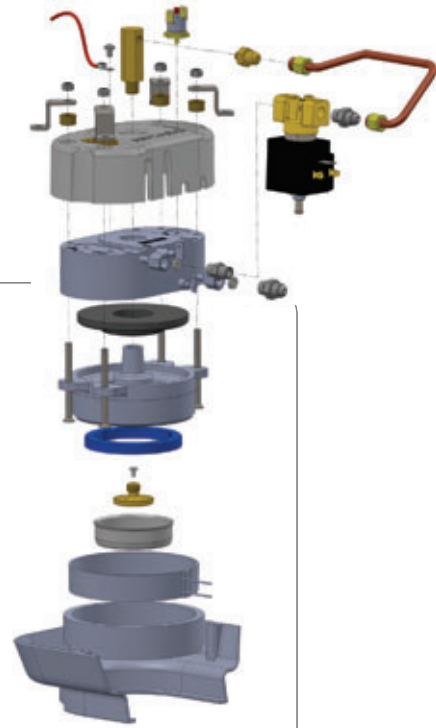

Independent steam boiler in AISI 316 stainless steel

Manufactured in 100% **AISI 316** stainless steel.

Plasma-welded both inside and out.

Extremely sturdy: Boiler thickness: 2.5 mm / Lid thickness: 10 mm

In addition, with more than **9 kg of thermal mass** in very thick AISI 316 stainless steel it provides exceptional thermal stability. This means that the steam pressure is kept constant and it uses less energy while at the same time maximising steam production.

Lime scale hardly ever adheres to stainless steel. This makes cleaning much simpler and means repairs are a thing of the past.

Our boilers (coffee and steam) include a **thermal sleeve** which reduces the machine's consumption by up to 35%.

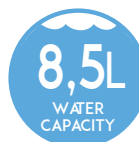

TECHNOLOGY

Quality taps

■ Steam and water taps.

Guaranteed long useful life. Brass "lead free".



■ Exclusive steam nozzle. Plus model.

Its ergonomic design has been tested by professional baristas.



■ Group Restrictors made of rubi.

Wear resistance and reduced possibility of scaling.



■ Solenoid valve-fed hot water. Plus model. Backlit stainless steel switch.



■ Safety switch per group. Plus model. Backlit stainless steel switch.



Electronic technology

■ High-quality electronic components.

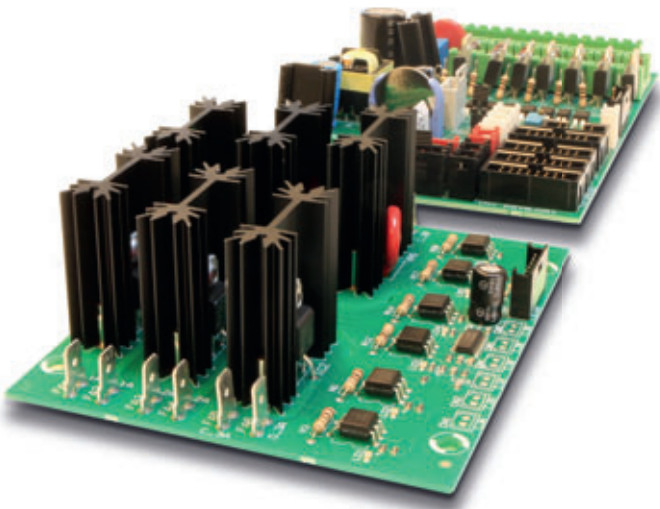

Double display per group



Display 1

- Independent electronic temperature control for the coffee group (PID). On/Off per group.
- Independent electronic temperature control for the steam boiler (PID). Independent On/Off.
- Counter (number of coffees, total and partial).
- Programmable pre-infusion (0 to 5 seconds). Precision 0,1 seconds. All selections adjustable.
- Pid parameters control (only technicians).
- Maximum adjustable power.
- Multiple Alarms display.

Display 2

Coffee dose timer.

BARISTA T PLUS CUSTOM

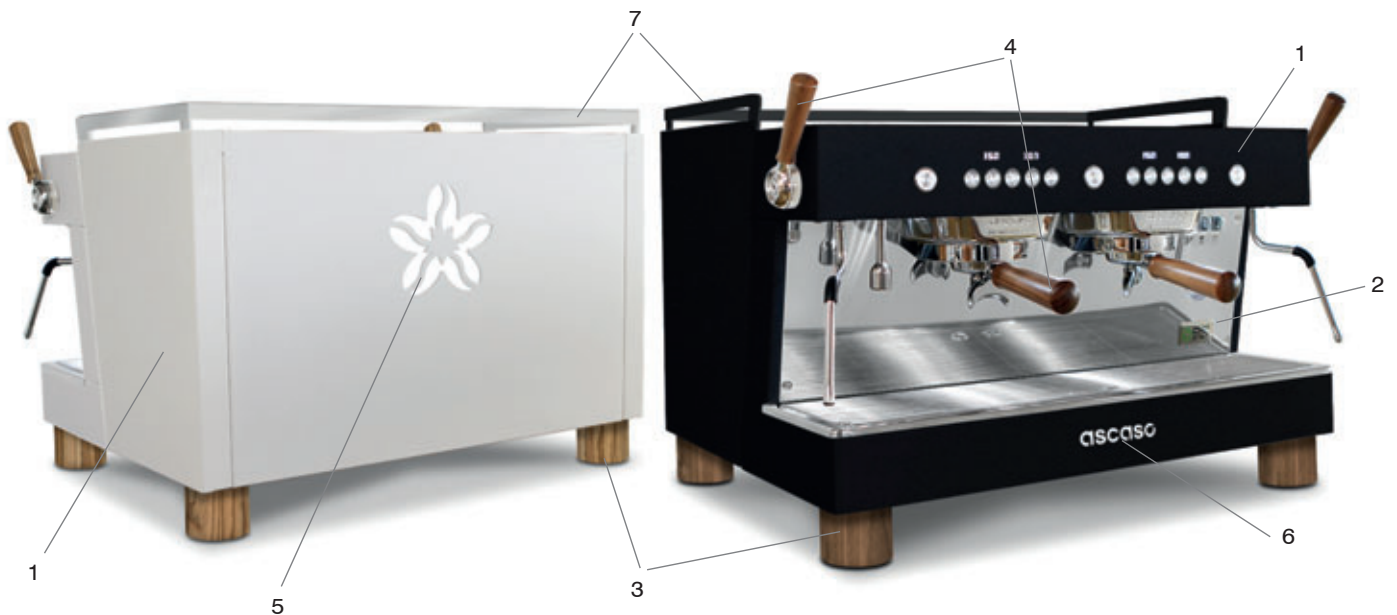

Barista T Customization 2GR/3GR

1 Shining stainless steel body. (Aisi 304)

1 Painted body, colour on request

2 Front panel colour

3 Walnut wooden legs (I.4597). 4 units

3 Olive wooden legs (I.4598). 4 units

3 Aluminium legs, colour on request. 4 units

4 Set of 3 filter holder handles + 2 olive steam knobs (I.4007+ I.3273)

4 Set of 4 filter holder handles + 2 olive steam knobs (I.4007+ I.3273)

5 Backlight rear logo (customer's logo)

6 Backlight front logo (Ascaso logo)

7 Stainless steel rail. Polished and shining on both sides.

7 Stainless steel rail, painted on both sides.



*Back light (option). Customization options

TECHNICAL DATA

	Barista T Zero	
	2GR/Compact	3GR
W/h/d dimensions (mm)	700/475/535	920/475/535
Compact W/h/d dimensions (mm)	560/475/535	
Boiler power (230 v)	3500W 50-60Hz (2000W Compact)	3500W 50-60Hz
Coffee group power (w)	1000 x 2	1000 x 3
Weight (kg)	71	93
Steam boiler capacity (l)	8,5 (4,5 Compact)	8,5
Steam	2	2
Water	1	1
Maximum Cup Height Normal/Raised (cm)	9/12	9/12
Dynamic pre-heating	●	●
Adjustable feet	●	●
Pump/boiler pressure double gauge	●	●
Rotary pump motor (200l)	●	●
Filter holder 1 coffee/2 coffees	1/2	1/3
Electronic autolevel	●	●
Boiler drain valve	●	●
Empty valve/safety valve	●	●
Volumetric dosing	●	●
Barista lights	●	●
Heating element & rotary pump stainless	●	●
Coffee temperature pid control (0,1°C precision)	1°C	1°C
Steam temperature pid control (1°C precision)	No. By Sirai	No. By Sirai
Digital multifunction display		
Pre-infusion	Adjustable On/ Off + 4 sec.	Adjustable On/ Off + 4 sec.
Group extra heating element		
Coffee group insulation		
Hot water with solenoid		
Steam boiler insulation		
Joy-stick taps		
Water temperature control (internal)		
Safety switch per group		
Active cupwarmer		
Wood accessories		
Chromed foots. Great thickness		



tradition & future

Since 1962 in the espresso world

“ Endeavour, determination, passion and a love of work. These have been our values for over 58 years. Today, each and every one of the people who work in this firm does so with the same will and enthusiasm. ”



Follow us on Instagram!



(34) 93 475 02 58
ascaso@ascaso.com
www.ascaso.com

Coneixement 1, Pol. Ind. GavaPark - 08850 - Gavá - Barcelona - Spain



REICICLABLE



LIBRE FSC



save paper
save tree

Technical specifications and models can change without notice.
Las especificaciones técnicas y los modelos pueden cambiar sin notificación.