

# Sharpen Less – Turn More

The Tormek TNT Sharpening system delivers a superior edge faster and easier than any method available today. You never remove more steel than necessary. The finer edge lasts longer so you spend less time sharpening and more time turning.



Tormek sharpening differs from other methods like high-speed grinders and belt sanders. Tormek makes a clear distinction between shaping and sharpening. Once the tool is shaped, when re-sharpening you remove a minimal amount of steel, you just touch up the edge. This is why we call it the TNT – or Touch and Turn – Sharpening System. An important benefit of the minimal steel removal is that your precious tools will last 8 to 10 times longer. You may never need to replace them as long as you live!

The patented TTS-100 Turning Tool Setter makes every aspect of the set-up simple and gives you the exact same geometry every time, regardless of changes in the stone diameter over the years. We have designed the TTS-100 with assistance from some of the top turners in the world. It will give you the tool shapes shown below in three easy steps. If you have specific requirements, any custom profile can be sharpened as well.

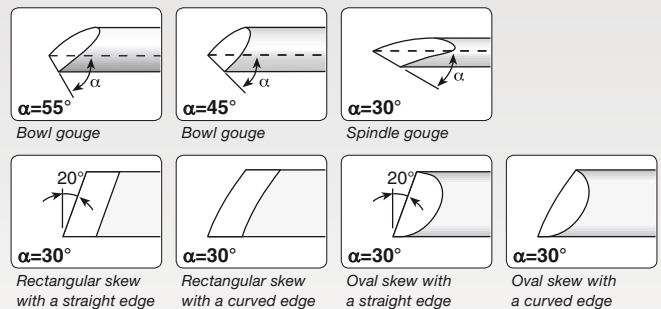

Most of our new TNT customers report that they have become a better turner. The tools now create the most delicate details and leave the cleanest cuts possible with little or no need for sanding. The tools will behave in exactly the same, predictable way all the time at the lathe. The edge stays sharp longer so you sharpen less and turn more!

## The Tormek way

TTS-100 setter exactly replicates the geometry on your bowl gouges, spindle gouges and skewes. Thanks to the patented design the TTS-100 gives an exact replication even when the stone decreases in diameter.



1 Mount the tool in the jig with a fixed protrusion.

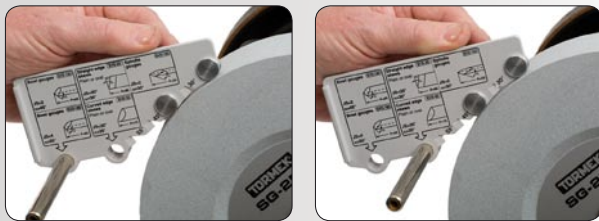

2 Set the Universal Support.



3 Touch up the edge.

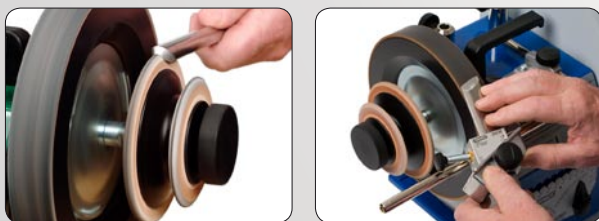

4 Hone and polish the edge to a razor sharpness.

## Questions and Answers

### Why does a Tormek edge cut more easily?

The Tormek stone and the leather Honing wheel create a very fine surface. A finer edge surface means a sharper edge, which cuts more easily.

### Why does a Tormek edge leave a smoother cut?

As the Tormek edge is sharper, it cuts the wood fibres more cleanly and leaves a smoother surface on the wood and there is less need for sanding.

### Why does a Tormek edge stay sharp longer?

There are two reasons. An edge from a high-speed dry grinder is rough whilst the Tormek sharpened edge is much finer. A finer edge is more resistant to wear. In addition, the Tormek never overheats the tool, avoiding loss of temper and micro-fractures.

### Why is the Tormek system fast?

The answer is the fast setting of the jigs and the exact repeatability.

### How can the Tormek stone last so long?

Since you just touch up the edge at each sharpening, the wear on the stone is limited.

### Shall I colour the bevel when using the TTS-setter?

No. The Tormek TTS-100 Setter replicates the edge angle.

### Shall I use slip stones after the sharpening?

No. The fine grindstone and the leather-honing wheel give you a superior sharpness without slip stones. The flute on gouges is honed and polished on the Profiled Leather Honing Wheel.

**Is the technique when shaping on the Tormek the same as on a bench grinder?** No. You need to press harder on the Tormek. There is no risk to your fingers since the stone runs slowly.

### How long does it take to shape a gouge and a skew?

Shaping takes 10 to 20 minutes depending on the initial shape and on how much steel you need to remove. Bear in mind that you normally shape the tool only once.

### Do I need a bench grinder?

Not necessarily. If you already own a bench grinder it could be used for the initial rough shaping. Leave the tip of the edge and the final shaping to the Tormek water cooled stone.

**Will a low speed 4-pole bench grinder eliminate the risk of burning the edge?** No. The speed is still too high even if it has only half the RPM of a conventional 2-pole grinder.



## TNT-708 Woodturner's Kit

This kit gives you the complete set of jigs and accessories you need to sharpen all your turning tools. It all comes in a handy storage box which you can save for permanent use on a wall or in a drawer.

The kit also includes the *Woodturner's Instruction Box* with a comprehensive 80 minute DVD and a detailed handbook. The film is made by Jeff Farris, an experienced USA woodturning instructor and the handbook is written by Torgny Jansson, the inventor of the Tormek system. If you already own a Tormek system you can update it with these items separately and fully utilize the Tormek method.

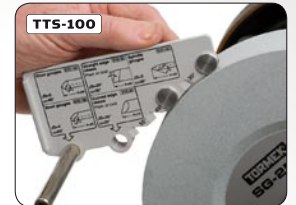

**TTS-100**  
**Turning Tool Setter**  
For setting the geometries on gouges and skewes.



**SVD-185**  
**Gouge and Cutter Jig**  
For fingernail shaped bowl gouges and spindle gouges.



**SVD-110**  
**Tool Rest with Torlock**  
For scrapers, hollowing tools and thin parting tools.

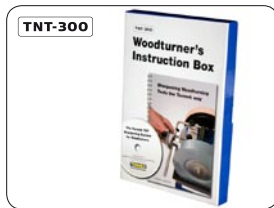

**TNT-300**  
**Instruction Box**  
A DVD plus a handbook on the Tormek TNT system.



**SVS-50**  
**Multi Jig**  
For skewes of any shape, even with an oval section.



**LA-120**  
**Profiled Honing Wheels**  
For honing the flutes. One radiused and one pointed.



**MH-380**  
**Machine Cover**  
For protecting the machine from shavings.

## Tormek T-7 Sharpening System

The T-7 model comes with the accessories shown here. Please visit our website for more information about the machine and the Tormek Sharpening System.



**WM-200**  
**AngleMaster**



**TT-50**  
**Truing and Dressing Tool**



**SP-650**  
**Stone Grader**



**SE-76**  
**Square Edge Jig**



**PA-70**  
**Honing Compound**



**HB-10**  
**Handbook**



**DVD-1**  
**Tormek DVD**

*"I use the Tormek system for all my tools. I usually sharpen them in the morning and hone them a couple of times during the day on the leather honing wheel. My jigs are set permanently and the sharpening only takes about a minute. As a production turner I value the short period of time I need to spend on sharpening, which gives me more time for turning. The edges also lasts much longer than when I was using a bench grinder and slip stones."*

Kurt Johansson  
Professional Woodturner, Sweden

*"Due to less frequent sharpening with wet grinding, the tool life is significantly prolonged, since less material is removed. The evidence suggests that using a wet-grinding method gives a sharper edge and cleaner cuts with more than double the effective turning time between sharpening. After 18 minutes of continuous turning in softwood, the wet-ground tool was still cutting more than 3.5 times faster than the dry ground tool."*

Robbie Farrance  
Woodturning Magazine, UK  
(The full article can be downloaded from the Tormek website)

*"Speed of sharpening depends as much or more on how much steel has to be removed as how fast the steel is removed. High speed grinders can remove a large amount of steel relatively quickly, but for most uses, the angles have already been established. Afterwards, only a small amount of removal is needed to re-sharpen. The more accurately the original angle can be duplicated, the faster the process. For turning tools, in particular, this is what makes the Tormek faster than even high speed grinders."*

Lyn J. Mangiameli  
Woodturner and tester, USA

The Tormek Sharpening System includes purpose designed jigs for most types of tools. Here is a survey of the Tormek programme.

**Tormek T-7 Sharpening System**

TORMEK T-7, SE-76, TT-50, SP-650, WM-200, PA-70, HB-10, DVD-1

**TNT-708 Woodturner's Kit**

SVD-185, SVS-50, SVD-110, LA-120, MH-380, TTS-100, TNT-300

**HTK-705 Hand Tool Kit**

SVM-45, SVM-140, SVX-150, SVA-170, SVS-32

**Grinding Jigs and Accessories**

SVH-320	Planer/Jointer Blade Jig			
SVP-80	Moulding Knife Jig			
SE-76	Square Edge Jig			×
SVD-185	Gouge and Turning Cutter Jig		×	
SVS-50	Multi Jig		×	
SVS-32	Short Tool Jig	×		
SVD-110	Tool Rest with Torlock		×	
SVA-170	Axe Jig	×		
SVM-45	Knife Jig	×		
SVM-140	Long Knife Jig	×		
SVX-150	Scissors Jig	×		
TT-50	Truing and Dressing Tool			×
WM-200	AngleMaster			×
SP-650	Stone Grader			×
LA-120	Profiled Leather Honing Wheel		×	
LA-124	Narrow discs for LA-120			
PA-70	Honing Compound			×
TTS-100	Turning Tool Setter		×	
MH-380	Machine Cover		×	
HB-10	Handbook			×
DVD-1	Tormek DVD			×
TNT-300	Woodturner's Instruction Box		×	