

ADVANCED MACHINERY

WWW.ADVMACHINERY.COM

Multitools fit all popular brands of grinders with bolt-on type wheel guards using the standard adapter. We recommend at least 1/3 HP minimum power high quality grinder for the MT362, 1/2 HP minimum for the MT482, and 1 HP minimum for the MT364 and MT484 models. Shaft size must be 1/2" or 5/8" (drive drum can be bored by customer for larger shafts up to 3/4"). An instruction manual and fitting kit, including the universal adapter with radial slots as seen below, are included. Multitools will NOT fit a grinder with heavy cast wheel guards if the guards are used to retain the spindle bearings.

Dimensions of included Adapter Plate

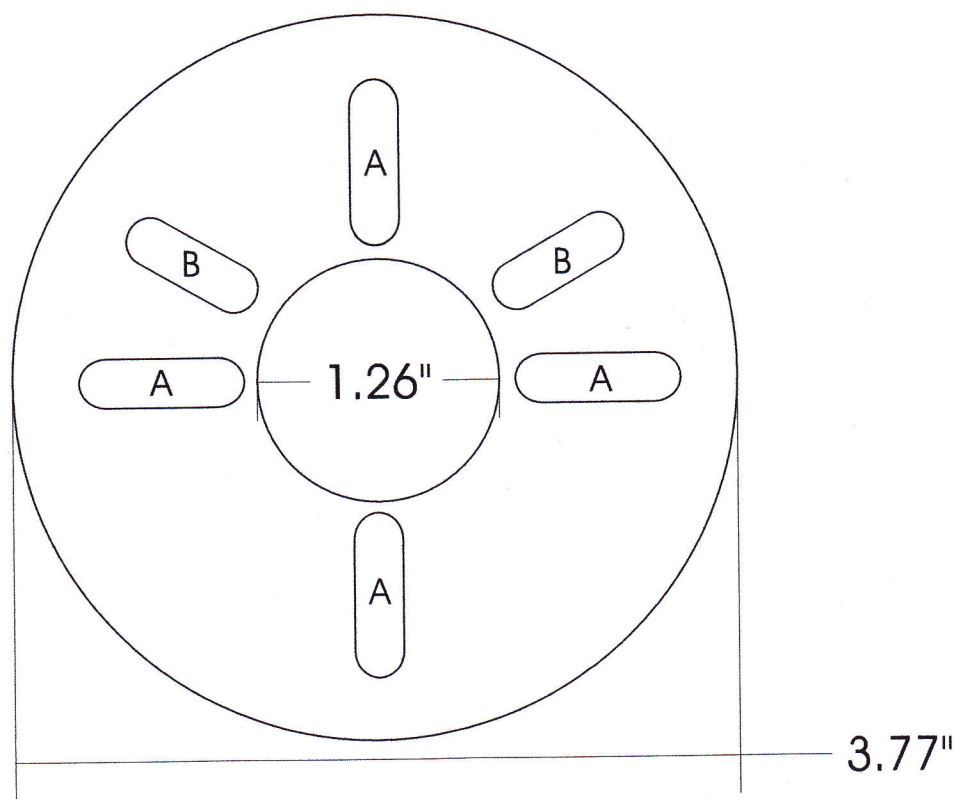

Slots A are used on 4-bolt patterns, slot dims of .860 x .245
Slots B are used on 3-bolt patterns, slot dims of .730 x .245