

# **HEGNER**

HEGNER Woodturning Lathe HDB 200  
Assembly and Operating Instructions

- Contents:
1. Safety Instructions
  2. Lathe Assembly
  3. Lathe Set-Up
  4. Changing Speed
  5. Changing Accessories

1. Safety Instructions

MAKE SURE MACHINE IS NOT PLUGGED INTO ELECTRICAL SOCKET when changing speed, changing accessories, or making adjustments.

ALWAYS WEAR SAFETY GLASSES when operating lathe.

DO NOT WEAR LOOSE CLOTHING when operating lathe.

Use only sharp tools.

Always place tool rest as close to workpiece as possible.

Before starting, make sure workpiece is rigidly mounted between centers.

Do not exceed circumferential speed of 6000ft/min. (At 2800 RPM maximum diameter allowed is 8 inches.)

Remove lathe from crate and place lathe bed onto crate or other support upside down as shown in drawing.

Mount legs (parts 1 and 2) on lathe bed with eight hex-head screws.

Set machine upright on floor.

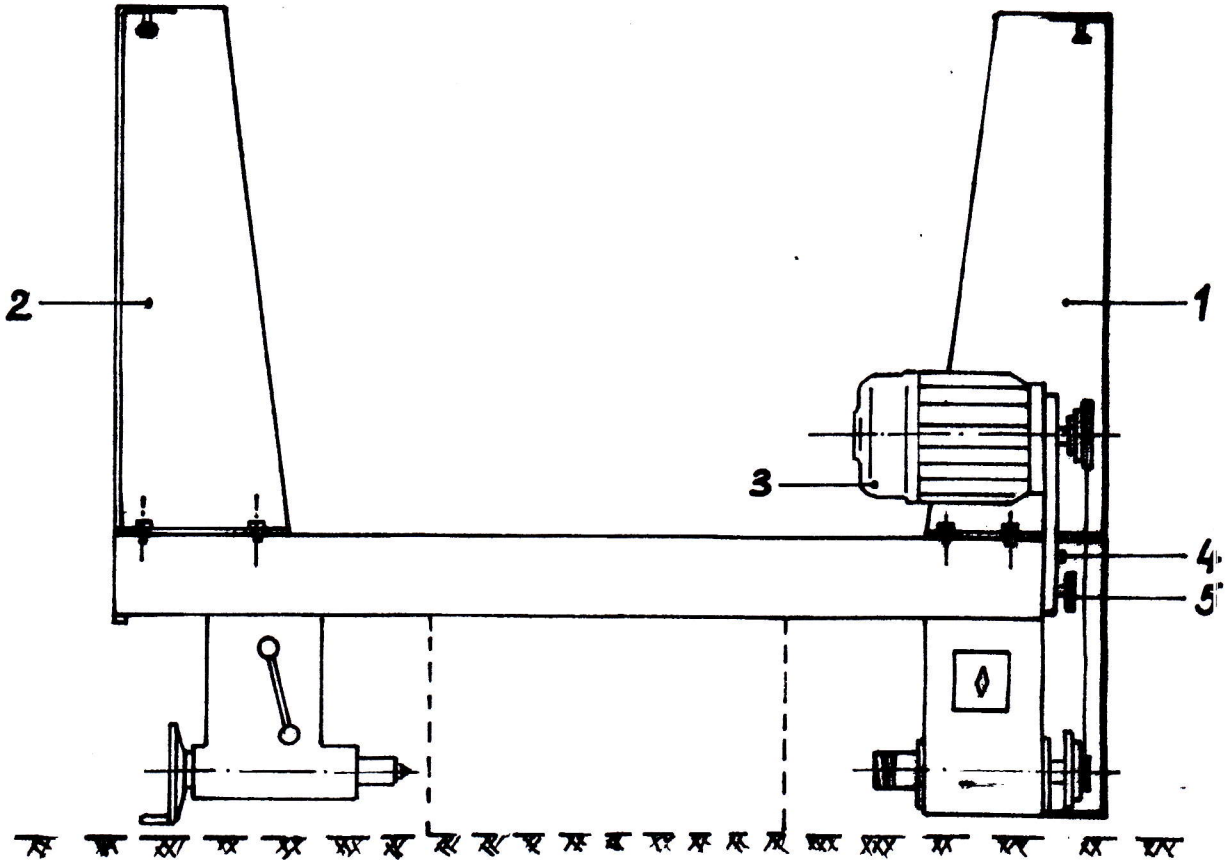

Position motor-mounting plate with motor attached (part 3) by placing slot in motor-mounting plate over guide pin (part 4); secure by inserting knob (part 5).

Raise motor-mounting plate with supplied tool (see paragraph 4) and place V-belt onto pulleys.

Tighten knob (part 5).

Connect motor cable to cord.

### 3. Lathe Set-Up

After assembling lathe, remove rust protective from all exposed areas. Adjust screws at bottom of lathe legs so that the machine is steady on the floor. If desired, anchor legs to floor.

#### 4. Changing Speed

See paragraph 1. on safety instructions for maximum circumferential speed allowed. To change speed, remove plug from electrical socket and open cover. Loosen knob (part 5). Use supplied steel lever to raise motor-mounting plate by pushing it through the bore of the steel joint. Tighten knob (part 5), and place belt on desired pulleys. Loosen knob (part 5) again and lower motor. Tighten knob and close cover.

#### 5. Changing Accessories

When changing accessories or driving centers, always remove all sawdust or wood chips from threads. Faceplate, cup chucks, and 3-jaw as well as 4-jaw universals screw directly onto headstock thread. Use two supplied steel levers to tighten and loosen driving center.

To mount live center in tailstock, turn wheel clockwise two turns, insert live center, and secure by tightening side lever.

To remove live center from tailstock, loosen side lever and turn wheel counterclockwise until live center is expelled from tailstock.

