

Flexigas

Installation Guide

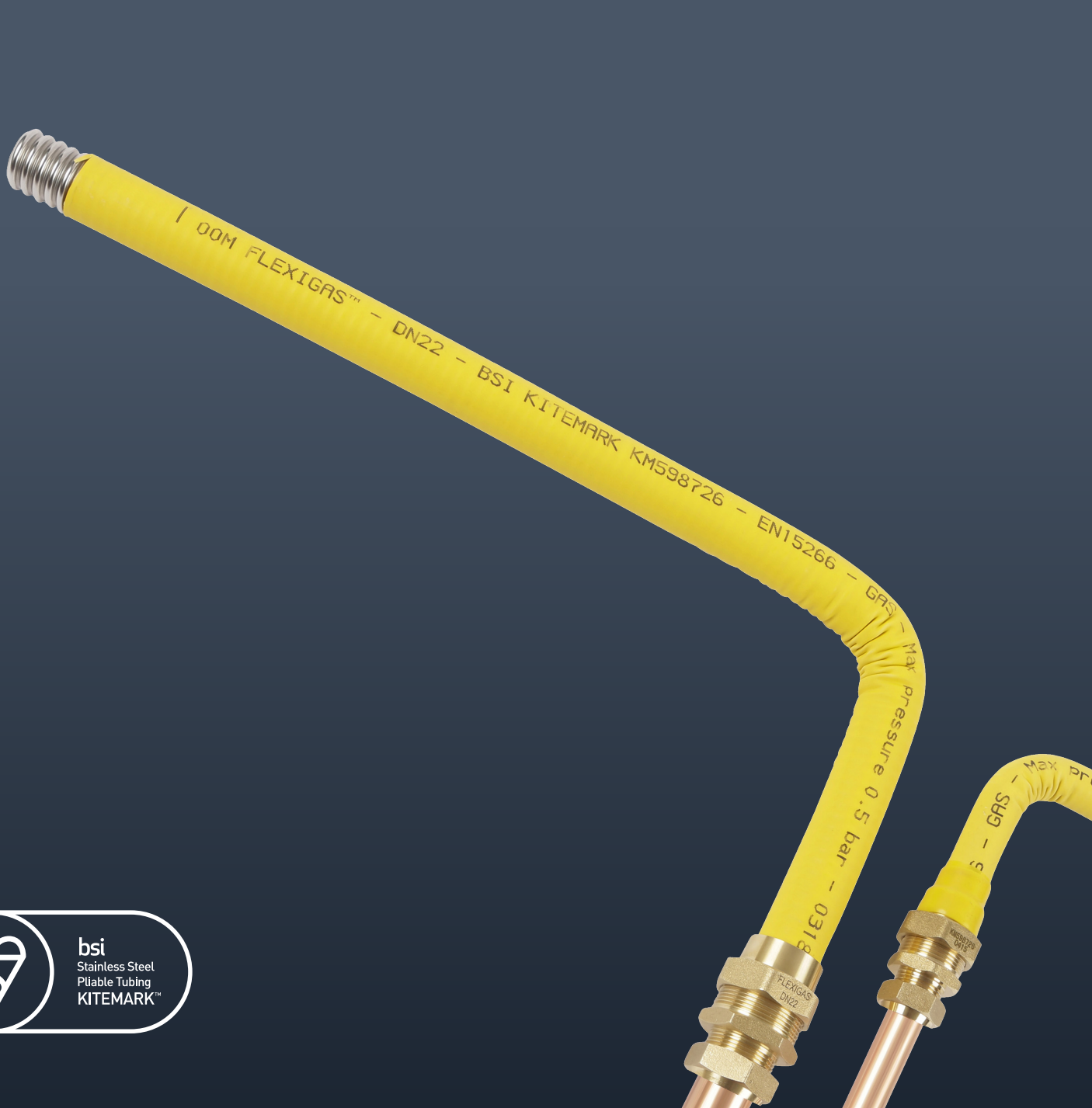

Important Notice

In the United Kingdom (including Northern Ireland and the Isle of Man) all work on gas installations (including but not limited to the servicing, installation and maintenance of the Flexigas system, or any attached gas appliance, fittings or conveyance system) must be carried out by a business or self employed persons approved by the Health and Safety Executive. At the time of publication of this manual the current registration body is the Gas Safe Register.

Persons operating as gas engineers must hold a valid certificate of competence for this work activity. This certificate must have been issued under the Nationally Accredited Certification Scheme (ACS) or a National/Scottish Vocation Qualification (NVQ/SVQ) that is allied to the ACS.

All gas work and installations, including the installation of the Flexigas system, must always be carried out in accordance with The Gas Safety (Installation and Use) Regulations 1998 (including additions and addendums), British Standards, Local Building Regulations and this Installation Manual. While FlexiPipe-Flexigas Ltd will make every endeavour to update this installation manual to follow any changes to the Regulations and British Standards, it may not always be possible to do so. The qualified gas engineer using the Flexigas system must always ensure they are aware of any changes to the Local/National Regulations that apply to the work they are carrying out. In the event of a discrepancy between any Regulations/British Standards and this Installation manual the former shall take precedence.

Only components provided or specified by FlexiPipe-Flexigas Ltd as comprising part of the approved Flexigas Corrugated Stainless Steel Tubing (CSST) system for gas installations may be used in the installation. The direct joining of the Flexigas system with other flexible piping systems has not been tested and is strictly forbidden. Joining of the Flexigas system to other piping systems (including other flexible CSST piping systems) is only permitted by use of an approved BSP thread connector as outlined in this manual.

While CSST gas systems such as Flexigas provide significant safety advantages over rigid gas delivery systems (including reduced likelihood of leakage due to faulty installation and damage caused by geological events such as earthquakes), due to its reduced wall dimensions CSST may be more likely than rigid systems to be damaged by sharp objects, such as a nail or a screw, or by other unique occurrences, such as a lightning strike. The proper grounding/earth bonding of the system will significantly reduce the risk from the latter and all installed Flexigas systems must be electrically bonded as per this manual (section 20) and British Standards (in particular BS 6891).

The Flexigas system should not be installed in any location where an excess degree of heat is likely to build up or be installed where it might be exposed to any naked flame.

Improper use or installation of the Flexigas CSST system may result in serious consequences, including but not limited to, fire, explosions, asphyxiation and gas poisoning. The Flexigas system must always be installed in strict accordance with British Standards, all applicable local or national regulations, and always by a licensed professional. All installed Flexigas systems must be inspected by an authorised local building official, as well as properly pressure tested, prior to being placed in service. FlexiPipe-Flexigas Ltd will have no responsibility over any misrepresentation of the information contained in this manual or for any improper installation or repair work carried out that does not strictly comply with current British Standards.

Table of Contents

1 - SCOPE	4
2 - STANDARDS & REGULATIONS OF RELEVANCE TO THE INSTALLER.....	4
3 - COMPETENCE AND SYSTEM CONFORMITY	5
4 - THE FLEXIGAS SYSTEM AND ITS COMPONENTS	5
5 - HOW TO ASSEMBLE FLEXIGAS	8
6 - BEST PRACTICE	9
7 - SAFETY PRECAUTIONS BEFORE INSTALLATION WORK COMMENCES.....	9
8 - SPECIAL CARE WHEN LAYING OUT FLEXIGAS TUBING	10
9 - BEND RADII	10
10 - CONNECTION AND DISCONNECTION OF PIPES AND FITTINGS	10
11 - JOISTED FLOORS, ROOF SPACES & COMPARTMENT FLOORS	11
12 - FLEXIGAS IN SOLID FLOORS.....	18
13 - FLEXIGAS IN WALLS	22
14 - SLEEVES	30
15 - FLEXIGAS IN DUCTS	31
16 - FIRE PROTECTION/STOPPING	32
17 - PIPE SUPPORTS	35
18 - EXTERIOR PIPEWORK.....	35
19 - INTERRELATION WITH OTHER SERVICES	37
20 - MAIN EQUIPOTENTIAL BONDING	37
21 - VALVES (EMERGENCY CONTROL VALVES).....	40
22 - PREVENTION OF CORROSION	41
23 - GAS TIGHTNESS TESTING AND PURGING	42
24 - CONNECTION OF FLEXIGAS TO OTHER SYSTEMS	42
25 - DAMAGE AND REPAIR.....	43
26 - WARRANTY	43
27 - PIPE SIZING (INCLUDING EXAMPLE).....	44
28 - SIZING TABLES	46

1 - SCOPE

The key installation standard for the use and installation of Flexigas is BS 6891:2015. Any installer using Flexigas must be familiar with the updated version of this standard. This installation manual highlights key points of relevance from this standard however it not intended to cover every aspect of BS 6891 as it relates to the use and installation of gas pipework including Flexigas. This installation manual should never be used as a replacement for BS 6891 or The Gas Safety (Installation and Use) Regulations 1998.

The Flexigas stainless steel corrugated tubing (CSST) system is approved for installations of natural gas and LPG in domestic, commercial and industrial applications.

This approval is made by British Standards Institute in accordance with BS7838: Specification for corrugated stainless steel semi-rigid pipe and associated fittings for low-pressure gas pipework of up to DN 50 and EN15266:2007 Stainless steel pliable corrugated tubing kits in building for gas with an operating pressure up to 0.5 bar.

The BS Kitemark number for the Flexigas system is KM693150 and KM 598726.



BS 7838
KM 693150



EN 15266
KM 598726

2 - STANDARDS & REGULATIONS OF RELEVANCE TO THE INSTALLER

The below is a non-exhaustive list and the competent installer using the Flexigas system should consult any relevant standard for the work they are carrying out.

BS 6891:2005 – Installation of low pressure gas tubing of up to 25mm (R1 1/4) in domestic gas premises (2nd family gasses).

BS 7838: Specification for corrugated stainless steel semi-rigid pipe and associated fittings for low-pressure gas pipework of up to DN 50

BS/EN 15266:2007 Stainless steel pliable corrugated tubing kits in building for gas with an operating pressure up to 0.5 bar.

BS 5482 – Code of practice for domestic butane and propane gas-burning installations Part 1: Installations at permanent dwellings, residential park homes and commercial premises, with installation tube sizes not exceeding DN 25 for steel and DN 28 for corrugated stainless steel copper.

IGEM/UP/2 Edition 2 – The Institution of Gas Engineers and Managers Communication – Installation pipework on industrial and commercial premises.

BS 7671:2008 – Requirements for electrical installations. IEE Wiring Regulations. Seventeenth edition.

BS/EN 1775:2007 – Gas supply. Gas tubing for buildings. Maximum operating pressure less than or equal to 5 bar. Functional recommendations.

3 - COMPETENCE AND SYSTEM CONFORMITY

Persons conducting gas installations like installing or repairing the Flexigas system must hold a valid certificate of competence for this work activity. This certificate must have been issued under the Nationally Accredited Certification Scheme (ACS) or a National/Scottish Vocation Qualification (NVQ/SVQ) that is allied to the ACS.

Only components provided or specified by FlexiPipe-Flexigas Ltd as comprising part of the approved Flexigas Corrugated Stainless Steel Tubing (CSST) system for gas installations may be used in the installation. The direct joining of the Flexigas system with other flexible piping systems has not been tested and is strictly forbidden. Joining of the Flexigas system to other piping systems (including other flexible CSST piping systems) is only permitted by use of an approved BSP thread connectors as outlined in this manual.

4 - THE FLEXIGAS SYSTEM AND ITS COMPONENTS

Tubing

Flexigas Tubing is made from 316L stainless steel with a flame retardant Polyethylene cover.

Tubing Size	DN 15	DN 22	DN 28	DN 32
Outer Diameter (without cover)	18.11mm	25.6mm	32mm	38mm
Internal Diameter	14.1mm	21.4mm	27mm	33mm
Tubing Wall Thickness	0.25mm	0.25mm	0.25mm	0.25mm
Polyethylene Cover Thickness	0.80mm	0.80mm	0.80mm	0.80mm



Fittings

All our fittings are made with DR Brass with annealed Copper gaskets. All installers must make sure the copper gasket is correctly in place on the seat inside the fitting before making any connections.



Male Coupling

SM1512	DN 15 (Flexigas) x 1/2" BSP Thread
SM2234	DN 22 (Flexigas) x 3/4" BSP Thread
SM2810	DN 28 (Flexigas) x 1" BSP Thread
SM32114	DN 32 (Flexigas) x 1-1/4" BSP Thread



Female Union

SF1512	DN 15 (Flexigas) x 1/2" BSP Thread
SF2234	DN 22 (Flexigas) x 3/4" BSP Thread
SF2810	DN 28 (Flexigas) x 1" BSP Thread
SF32114	DN 32 (Flexigas) x 1-1/4" BSP Thread



Coupling Union (Flexigas)

SU15	Flexigas DN 15 x DN 15
SU22	Flexigas DN 22 x DN 22
SU28	Flexigas DN 28 x DN 28
SU32	Flexigas DN 32 x DN 32



Tees

TT15	Flexigas DN 15 x DN 15 x DN 15
TT22	Flexigas DN 22 x DN 22 x DN 22
TT28	Flexigas DN 28 x DN 28 x DN 28
TT32	Flexigas DN 32 x DN 32 x DN 32



Reducing Union

SR2215	Flexigas DN 22 x DN 15
SR2815	Flexigas DN 28 x DN 15
SR2822	Flexigas DN 28 x DN 22
SR3228	Flexigas DN 32 x DN 28



Reducing Tee

TR221515	FlexigasDN22 x DN15 x DN15
TR221522	FlexigasDN22 x DN15 x DN22
TR222215	FlexigasDN22 x DN22 x DN15
TR282215	FlexigasDN28 x DN22 x DN15
TR282222	FlexigasDN28 x DN22 x DN22
TR322222	FlexigasDN32 x DN22 x DN22
TR322822	FlexigasDN32 x DN28 x DN22

Copper compression



CC1515	Flexigas DN15 x 15mm copper
CC2222	Flexigas DN22 x 22mm copper
CC2822	Flexigas DN28 x 22mm copper
CC2828	Flexigas DN28 x 28mm copper
CC3228	Flexigas DN32 x 28mm copper
CC3235	Flexigas DN32 x 35mm copper

Tubing Cutter

You can use any standard metal wheel pipe/tube cutter to cut Flexigas. It is important to use an appropriate size cutter (with appropriately sized cutting wheel) for the tubing size you are trying to cut. This will ensure a cleaner circular cut which is important for forming a proper seal. Tubing cut with an incorrectly sized cutter may damage the tube and make it impossible to form a proper seal.

We recommend the Lennox pipe cutter for smaller sizes (DN 15, DN 22) and the Monument pipe cutter for larger sizes (DN 28, DN 32). These are available from plumbing merchants throughout the UK.

5 - HOW TO ASSEMBLE FLEXIGAS



Step 1 - Cut

Cut the Flexigas tubing using a wheel metal pipe cutter. Ensure the cut is centered in the valley between corrugations and the cutter is only slightly tightened on each full revolution around the tube. Make sure the cut is clean and circular with no sharp edges.



Step 2 - Remove

With a utility knife, safely remove the flame retardant yellow cover so that the last four corrugations are exposed.



Step 3 - Slide

Slide the nut over the tubing and then place the two semi-circular collets around the tubing so that the ridges on the collets occupy the last three valleys of tubing.



Step 4 - Tighten

Make sure the copper ring is in place on the seat inside the fitting before inserting the collets into the fitting. Tighten the nut and fitting using two suitably sized wrenches. The seal is formed when the last corrugation deforms around the copper seat inside the fitting. Use sufficient torque.



Step 5 - Wrap

After conducting a gas tightness test, wrap the small gap between the 'tail' on the nut and the tube using yellow silicone tape.

6 - BEST PRACTICE

The following is considered general best practice when installing Flexigas:

- Ensure all Flexigas components are physically stored, located or once installed located where it is not liable to mechanical damage.
- Ensure the bore of the Flexigas tubing is not restricted by kinks, burrs, foreign material or in any other way.
- Ensure that you have adequate length of Flexigas tubing before you start work and where possible make continuous runs of tubing.
- Take care when opening the packaging as the pipe is stored in a coil and will release upon opening.
- While unrolling the tubing ensure that no kinks or twisting in the tube occurs.
- Ensure that neither the tube nor fittings are stored in extreme temperatures, however where they have been exposed to such temperatures do not make any connections of the components before they have returned to room temperature.

Anytime after the tubing or fittings have been removed from their packaging, and especially during installation on site, care should be taken so that dirt, water or other building materials does not enter the tubing.

Any foreign material entering the system can severely restrict normal flow and even restrict flow altogether.

7 - SAFETY PRECAUTIONS BEFORE INSTALLATION WORK COMMENCES

Where work is taking place on pipe already connected to a gas meter either

1. The meter should be disconnected with both open ends of the tubing sealed with dust caps fitted to the meter, or
2. All open ends of the tubing will be terminated with a self sealing appliance connector that conforms to BS 669: Part 1 or BS 669: Part 2.

After the completion of work all open ends of the tubing shall be plugged, capped or terminated with a self sealing appliance connector complying with BS 669: Part 1 or BS 669: Part 2.

Installers also need to consider the risk of persons restoring the gas supply at the primary meter should they leave the general location where the work is in progress.

8 - SPECIAL CARE WHEN LAYING OUT FLEXIGAS TUBING

Flexigas is easily introduced and passed along small spaces where it might be hard to see the location of existing services. As such special care should be taken not to damage any existing services, in particular electrical services, such as cables, junction boxes, etc. Installers should also reference bonding requirements in Section 20.

The installer should also take note and mark the location of Flexigas tubing behind wall spaces, under flooring, or any other location that might put it at risk of being damaged by a nail, screw or other sharp object.

9 - BEND RADII

Flexigas can be easily passed around objects and bent by hand, including making tight bends if necessary. However, such tight bends should be avoided where possible as multiple tight bends can restrict gas flow and increase pressure drop.

It is preferable to make larger smoother bends with a higher radius to reduce pressure loss. It is also recommended to avoid repeated bending during installation.

Size	Min Bend Radius	Suggested Bend Radius
DN 15	20 mm	75 mm
DN 22	25 mm	75 mm
DN 28	75 mm	125 mm
DN 32	75 mm	125 mm

10 - CONNECTION AND DISCONNECTION OF PIPES AND FITTINGS

Where any installation pipe is no longer required, the pipe(s) shall be disconnected as close to the point of supply as practicable. All pipe ends shall be sealed with an appropriate fitting, e.g. a plug or cap.

During any work that necessitates connection or disconnection of any metal installation pipework, a temporary continuity bond shall be fixed where production of a spark or shock could cause a hazard, whether or not permanent equipotential bonding has been established (see Section 20).

Where practicable, any redundant pipework should be removed.

The recommended disconnection procedure is as follows:

1. Isolate the electrical connection of associated gas appliances from the electricity mains supply.
2. Clip or clamp a temporary continuity bond to each side of the union, fittings or complete section that is to be removed or connected ensuring that good metallic contact is made (see Figure 3).
3. Leave the bond in position until after the work is completed and metallic continuity re-established.

A recommended temporary continuity bond comprise at least 1.2 m of single-core insulated flexible cable or equivalent of at least 250 V rating. The cable should have a cross-sectional area of not less than 10 mm² and multi-strand flexible construction generally in accordance with BS 6004, BS 6007 or BS 6231 with a robust clip or clamp firmly attached at each end.

Where the meter is removed BS 6400 should be consulted.

11 - JOISTED FLOORS, ROOF SPACES & COMPARTMENT FLOORS

Flexigas laid in joisted floors and roof spaces shall run either in the direction of the joists or at 90° to the joist direction. Diagonal runs are not to be installed.

Notches shall be in accordance with the following Figures 1A -1D. Joists less than 100 mm or greater than 250mm shall not be notched.

Where Flexigas is installed between solid timber joists in floors, intermediate floors or roof spaces, it should be correctly supported in accordance with section 17:

- Where pipes are installed between timber engineered joists, the Flexigas shall be installed through the web of joists in accordance with Figure 1C and the joist manufacturer's guidance.
- Where pipes are installed between metal web joists the pipes shall pass between the metal webs with pipe supports fixed to the top or bottom of the timber flanges and not in contact with the metal structure of the joists.
- The flanges of timber engineered joists and metal web joists shall not be notched.
- Where pipes are laid across solid timber joists fitted with flooring they shall be located in purpose made notches or circular holes.
- Where pipework is installed within roof spaces, roof rafters, purlins, trussed rafters, bracing, etc., shall only be notched, drilled or cut away with the approval of a structural engineer.
- Prior to running pipework below suspended floors a visual inspection should be carried out to note the position of any electrical cables, junction boxes and ancillary equipment, in order that accidental damage or injury does not occur when inserting pipework.
- Where pipework is installed in a void under a floor, or where pipework is installed within intermediate joisted floors, unless there is sufficient adventitious ventilation available, ventilation shall be provided in accordance with Section 15. For LPG and LPG/air mixtures this ventilation shall be at the lowest point.
- Care should be taken when re-fixing flooring to prevent damage to the pipes by nails or screws. Where possible, the flooring should be appropriately marked to warn others. Where possible the design should remove the need for notching solid timber joists.

For best practice, it is recommended to keep fixings to a minimum (without going over the max distance between fixings outlined here or in BS 6891) to increase the likelihood of the tubing deflecting away from any protruding object such a nail or screw.

Pipework shall not be installed within any fire compartment floor that separates one dwelling from another part of the building, except as shown in Figure 1C & 1D.

Roof spaces utilizing vapour permeable underlay without specific ventilation, such as soffit board vents, shall be treated as unventilated voids for the purpose of gas pipework and appliance installations. Where it is necessary to install pipework in such locations, additional ventilation shall be applied having at least two ventilators per space, each with a free area of at least 50 cm². For LPG and LPG/Air mixtures, this shall be at low level; for natural gas this shall be at high level.

Pipework shall not be laid below or within roof space insulation material.

Figure 1A - Limits for notching and drilling of solid timber floor joists

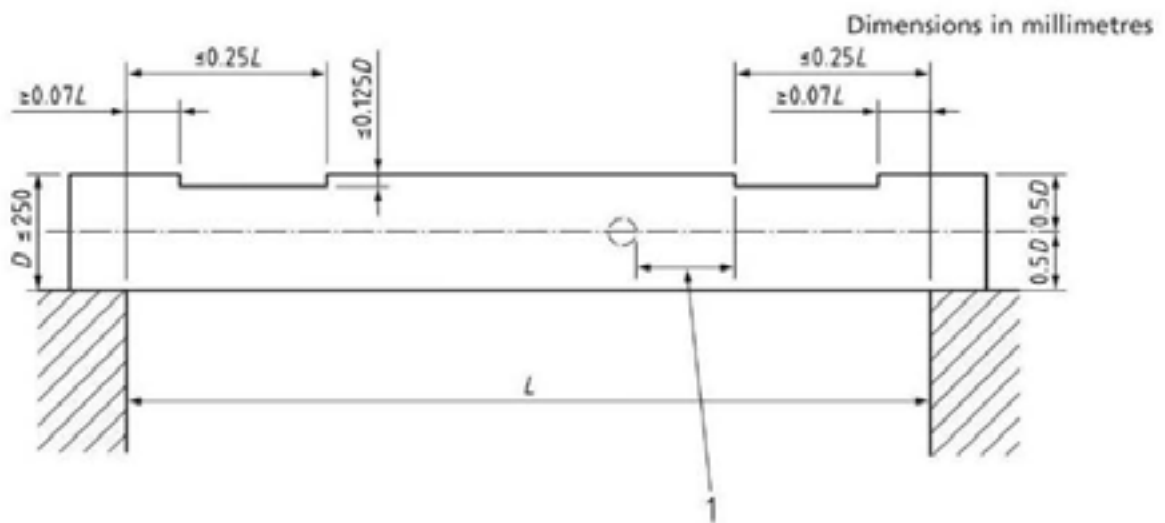

a) Limits for notching top of joist where drilling and notching occur

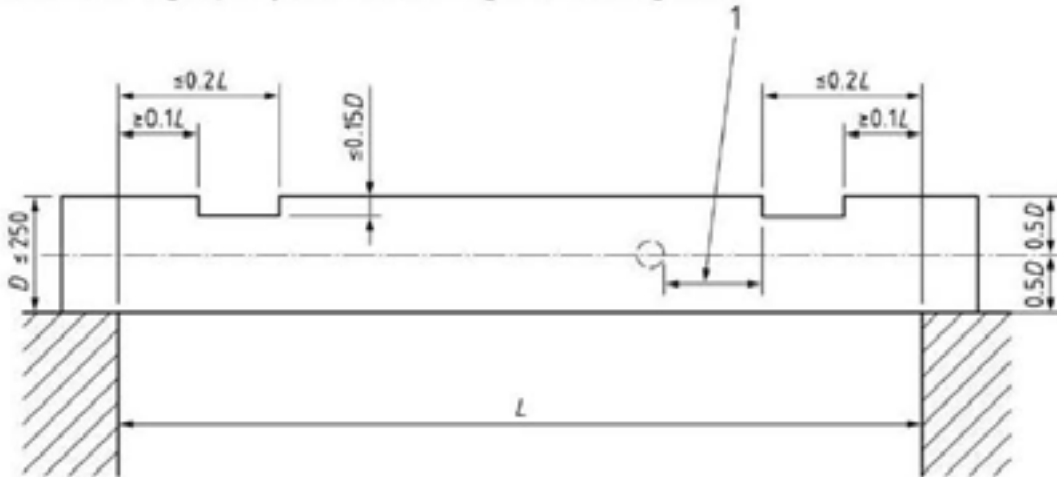

b) Alternative limits for notching top of joist where drilling and notching occur

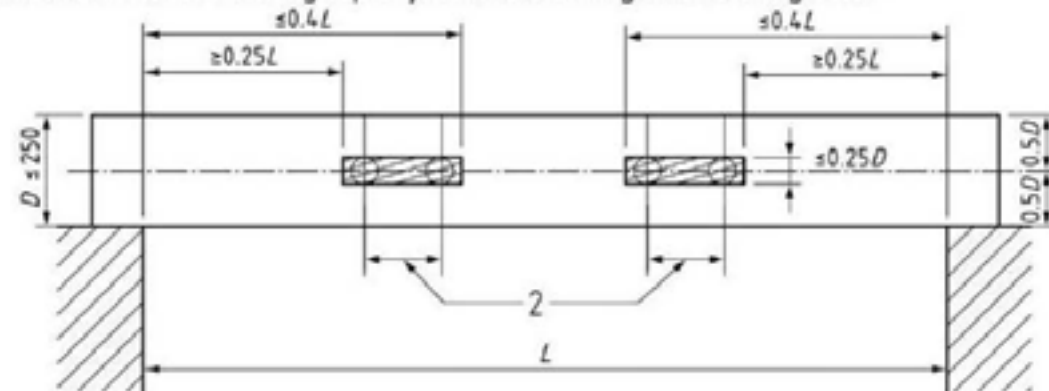

c) Limits for drilling of joists where drilling and notching occur

Key

- 1 Min. 100 mm between notch and hole 2 Holes not closer than 3 x diameter

NOTE 1 The notching can occur at both ends, either on top or bottom, without a design check.

Figure 1A - Limits for notching and drilling of solid timber floor joists

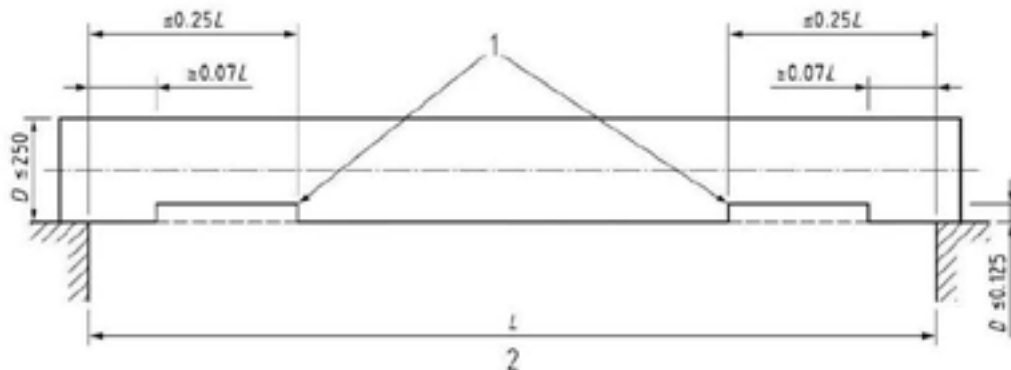

Key

- | | | | |
|---|---|---|---|
| 1 | Positions within which notching can occur on the bottom without a design check. Minimum 100 mm between the notch and any holes [see Figure 13a)]. | 2 | Clear span simply supported joist (not a trimmer, trimming joist or beam) |
|---|---|---|---|

NOTE 2 The notching can occur at both ends, either on top or bottom, without a design check.

d) Limits for notching bottom of joist where drilling and notching occur

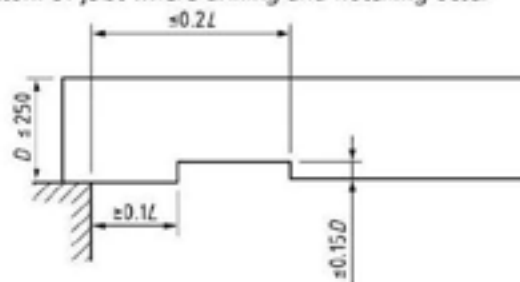

NOTE 3 The notching can occur at both ends on the bottom without a design check.

e) Alternative limits for notching: bottom of joist where drilling and notching occur

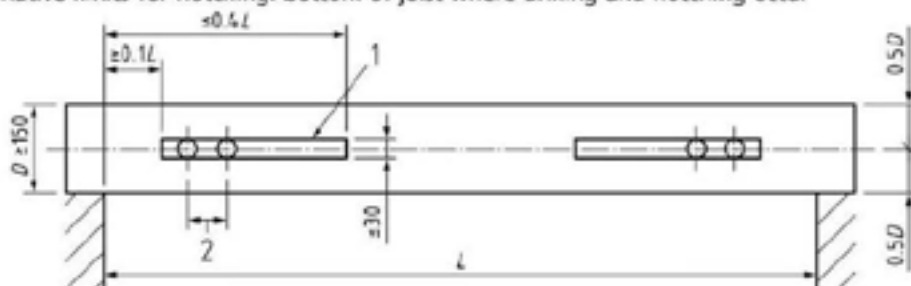

f) Alternative drilling zone where no notching occurs

Key

- | | |
|---|--|
| 1 | Drilling zone where no notching occurs |
| 2 | Holes not closer than 3 x diameter of largest hole and a maximum of 8 x 30 mm holes can be accommodated within each drilling zone. No notching is permitted. |

Figure 1B - Notching and drilling of metal web joists and timber engineered joists

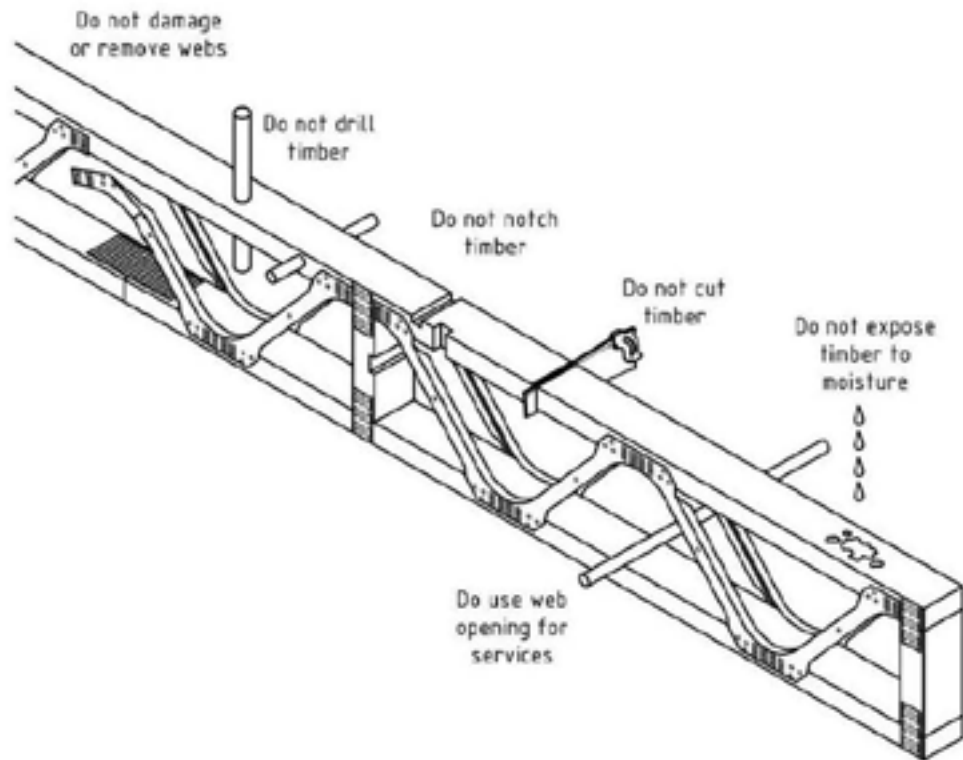

a) Restrictions on notching and drilling metal web joists

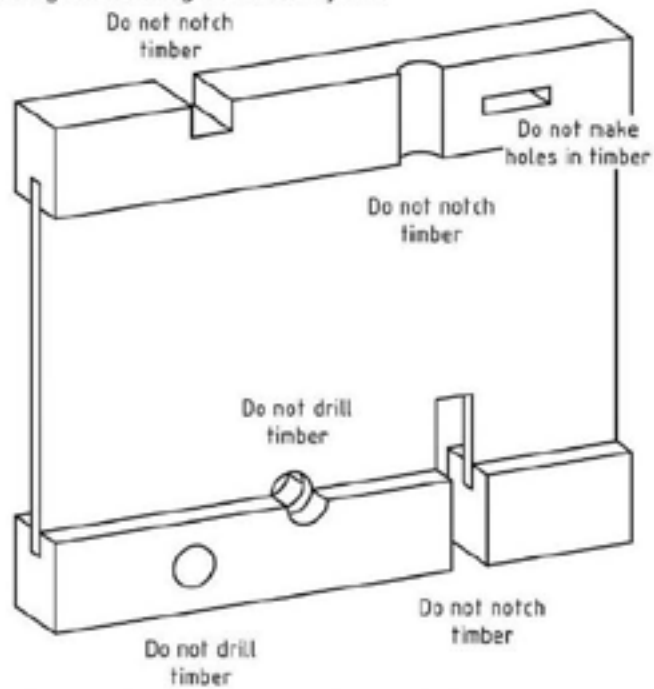

b) Restrictions on notching and drilling timber-engineered joists

Figure 1C – Flexigas in concrete compartment floors

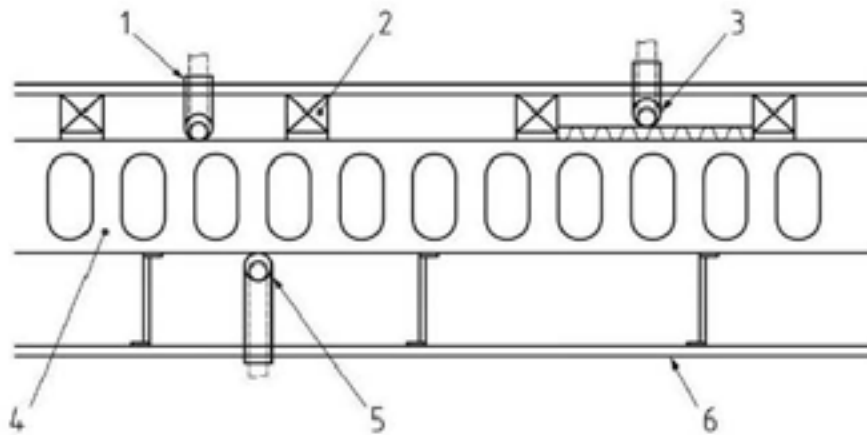

a) Typical concrete compartment floor with suspended ceiling and topping of timber decking on battens

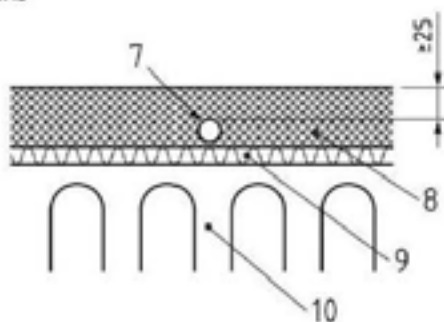

b) Alternative screed topping

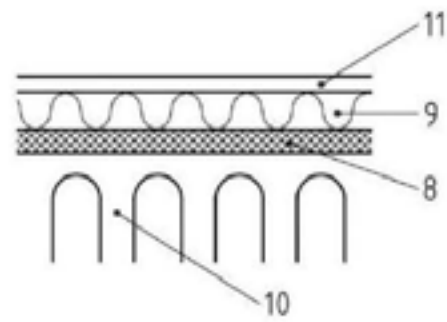

c) Alternative timber floating floor topping (No pipework to be installed in this type of floor topping)

Key

- 1 Pipework within vented ducting extended above floor level and sealed to floor deck with flexible sealant
- 2 Floor decking on battens on resilient bearers/pads
- 3 Ducted pipework can be above or below any resilient quilt laid between floor battens with no fixings used to secure the ducting penetrating or damaging the quilt
- 4 Structural floor slab
- 5 Pipework within vented ducting located within suspended ceiling void and sealed to ceiling board
- 6 Suspended ceiling
- 7 Pipework with factory-finished protection laid in screed above resilient overlay^{A2}
- 8 Screed
- 9 Resilient sound-proofing overlay
- 10 Structural floor slab
- 11 Floating floor

^{A2} Exposed metallic pipework, for example at joints, shall be further protected on site

Figure 1D – Flexigas in timber fire compartment floors

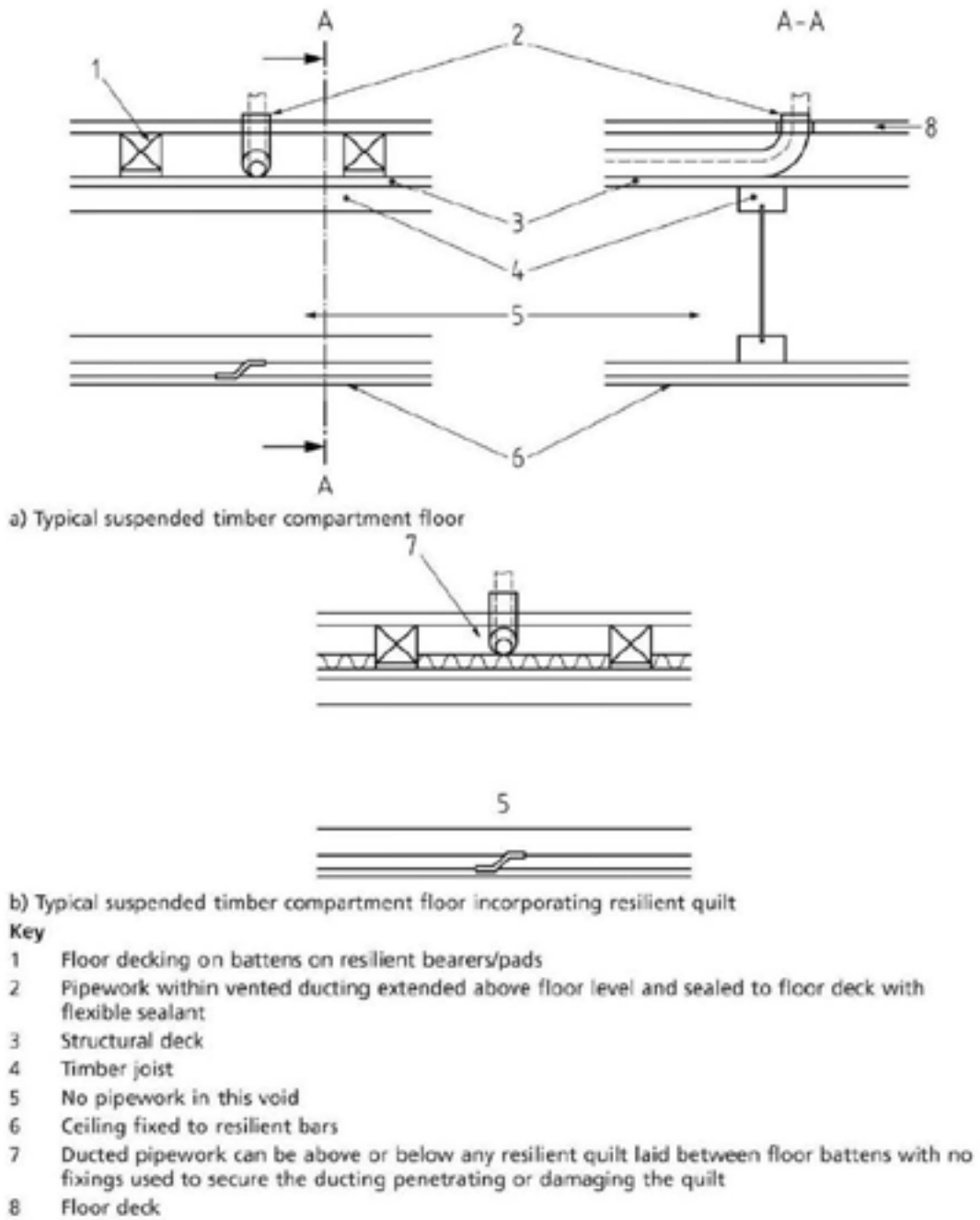

12 - FLEXIGAS IN SOLID FLOORS

The FlexiGas plastic cover complies with section 8.10.7 of BS 6891:2015 (specifically, with regards to cover thickness and chloride content of plastic cover) and therefore the cover meets the requirements for direct burial and does not require additional sleeving when being placed in floor screed. However, it is important to highlight section 8.10.6 of BS 6891:2015 and Regulation 208 19(2)b) of the Gas Safety (Installations and Use) Regulations also requiring all gas pipework to be protected against damage caused by movement as best as possible (for example from subsidence, or some other structural movement).

Therefore, if the gas installer judges that the FlexiGas tubing may be subject to unforeseen movement from the solid floor in which it is being placed, it is considered best practice to place the FlexiGas tubing in a suitable sleeve as per Section 14 (as would be done with rigid copper installations).

All buried pipework should be inspected for damage before being placed in a solid floor. Extra special attention should be given to any damage to the plastic cover where the installer will be installing FlexiGas tubing directly in floor screed without additional sleeving. Any gaps or holes in the plastic cover should be wrapped with silicone tape with at least 50% cover to provide a layer of double thickness.

The installed FlexiGas system should be tested for gas tightness before being covered by floor screed

Where a pipe is buried in a concrete screed there shall be a minimum of 25 mm of cover above the FlexiGas tubing or sleeve.

FlexiGas fittings shall not be directly buried in any solid floor. If a fitting is required within the floor screed or below ground boxes with removable covers are suitable so that the fitting can be accessed if needed. They are known 'conduit junction boxes' and will be available from your local plumbing merchant.

FlexiGas should never be buried in structural elements of the floor such as concrete slabs or structural toppings. Pipework shall not be buried in power-floated floors that form part of the structure. Pipework in acoustic floors shall only be installed with the agreement of the building designer.

Where pipework is to be installed in solid floors it shall run parallel or at 90° to the walls.

Examples of FlexiGas laid in concrete are shown in the following diagrams.

Figure 2A - Examples of Buried Pipe – Ground Bearing Concrete Floors

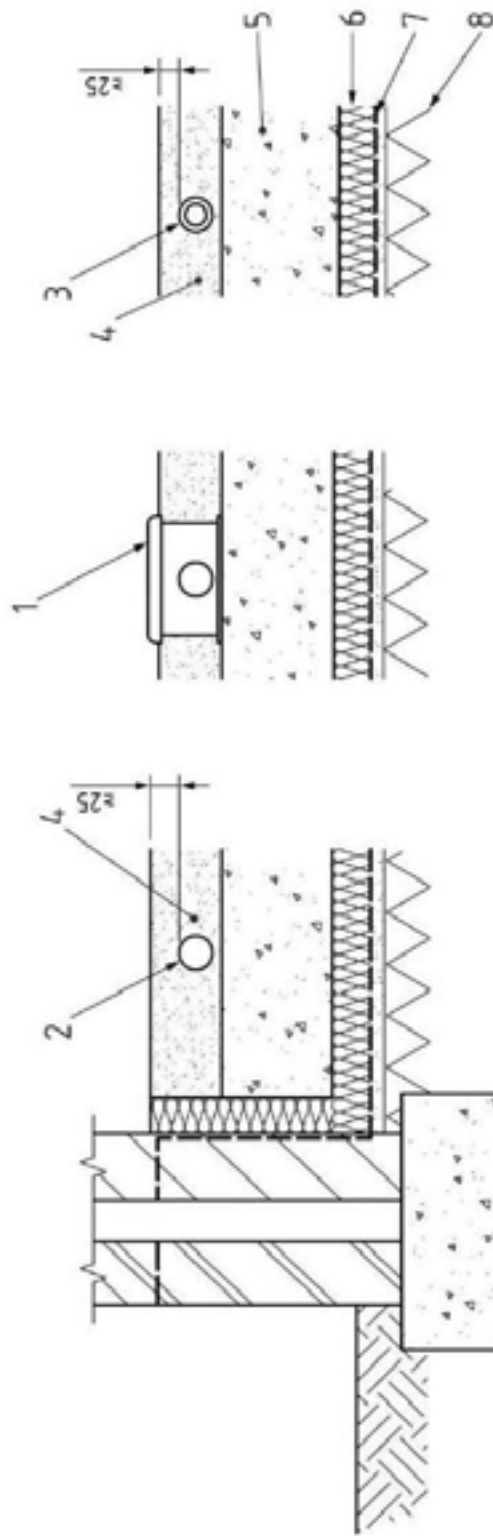

Key

- 1 FlexiGas laid in preformed duct
- 2 FlexiGas directly buried in screed (where considered necessary by installer - check cover for damage)
- 3 FlexiGas buried in screed (using best practice) with soft sleeving for additional protection against movement
- 4 Screed
- 5 Concrete slab
- 6 Insulation
- 7 Damp-proof membrane
- 8 Hardcore and sand blinding

Figure 2B - Examples of Buried Pipe – Suspended Concrete Floor

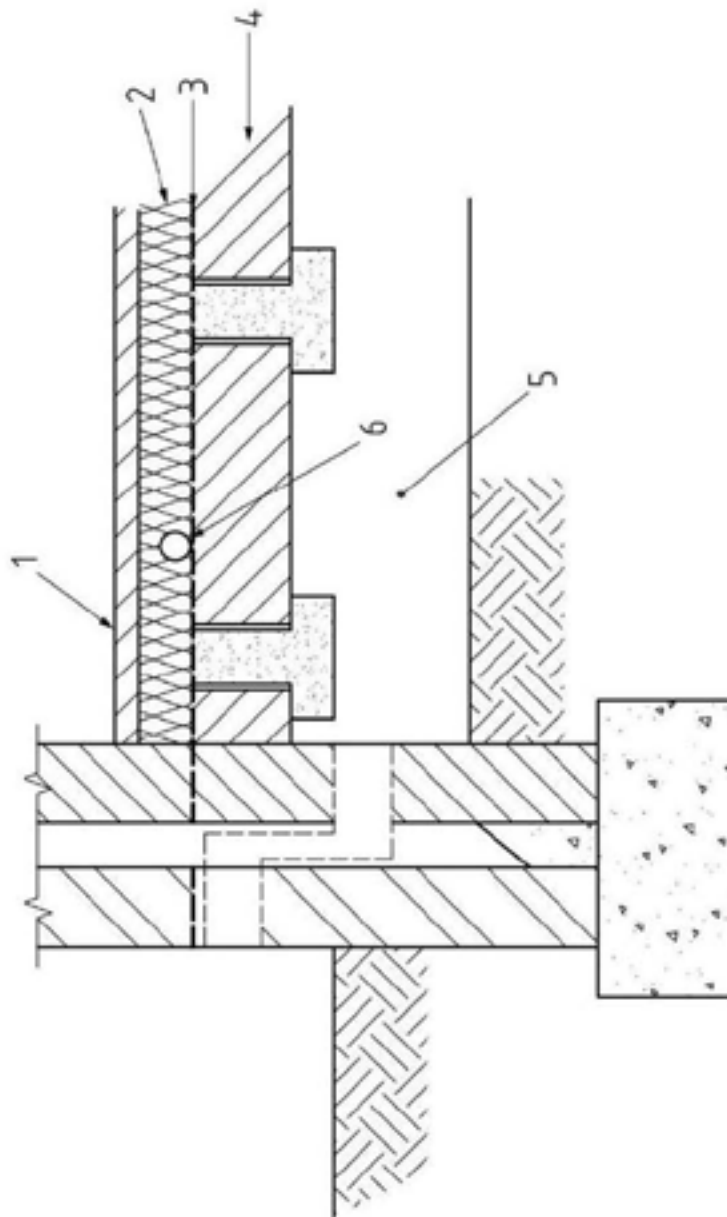

- Key**
- | | | | |
|---|---|---|------------------------|
| 1 | Chipboard or floor screed over insulation | 4 | Precast beam and block |
| 2 | Insulation | 5 | Ventilated void |
| 3 | Damp-proof membrane | 6 | FlexiGas |

Figure 2C - Examples of Buried Pipe – Concrete Rafts

Dimensions in millimetres

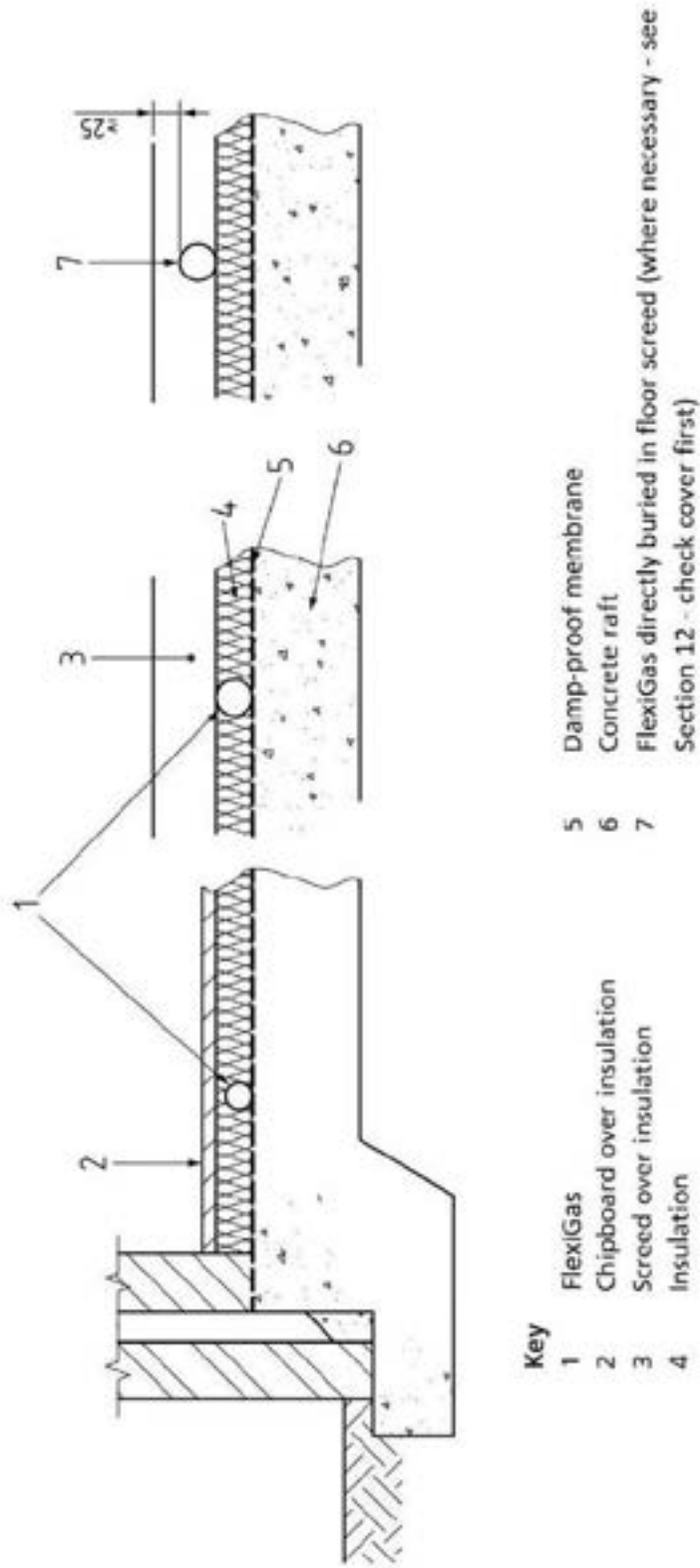

13 - FLEXIGAS IN WALLS

Flexigas tubing should be placed in walls by following the below procedures and diagrams.

For examples of Flexigas in timber and masonry walls please refer to the following diagrams:

- Brick and block plastered - Figure 3A
- Brick and block with dry lining on dabs - Figure 3B
- Brick and block dry lined on battens - Figure 3C
- Timber frame and light steel construction - Figure 3D -3G

Additional Procedures

Pipe Runs

Flexigas tubing shall, where possible, be vertical and shall be placed in ducts with convenient access points or placed in pipe chases.

The installation pipe shall be secured and have as few joints as practicable.

Damage

Flexigas tubing should be inspected for damage before being placed within a wall. Any damage to the plastic cover can be repaired using silicone tape, with at least 50% overlap cover from one pass to the next.

Cavity Walls

Flexigas tubing shall not be placed within the cavities of cavity walls. Every pipe passing through a cavity wall shall take the shortest practicable route and shall be sleeved (see Section 14).

Dry-Lined Walls

Flexigas tubing installed behind dry lining shall be suitably encased by building material. Where Flexigas tubing passes within 50mm of the decorative face of the plasterboard, it shall be protected against penetration, for example with 1mm steel plate.

Timber Construction And Light Steel Framed Walls

Flexigas tubing installed within walls of timber frame construction shall:

- be run within purpose-designed channels or ducts;
- be adequately secured;
- have as few joints as practicable;
- be protected from mechanical damage
- not be in position where the tube could be penetrated by a nail or screw 50mm long. The tubing must be placed at least 50mm from the face of the plasterboard or if not behind a steel plate with min thickness of 1mm.

Solid Walls

Where Flexigas tubing passes through a solid wall it shall be sleeved (see Section 14)

Figure 3A - Brick and Block Plastered

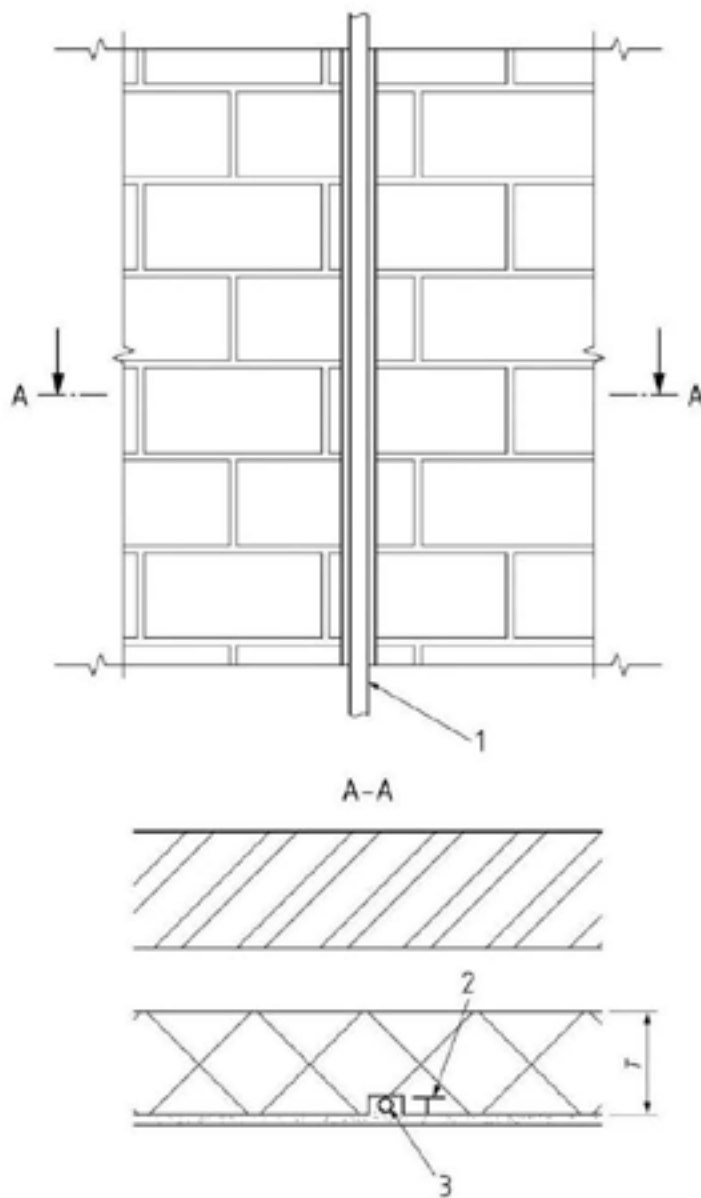

a) Brick and block plastered

Key

1 Pipework set in chase

2 Depth of chase

3 Pipework set into chase in plastered wall

Maximum depth of chase: $\frac{7}{16}$ horizontal; $\frac{7}{32}$ vertical

Figure 3B - Brick and Block with Dry Lining on Dabs.

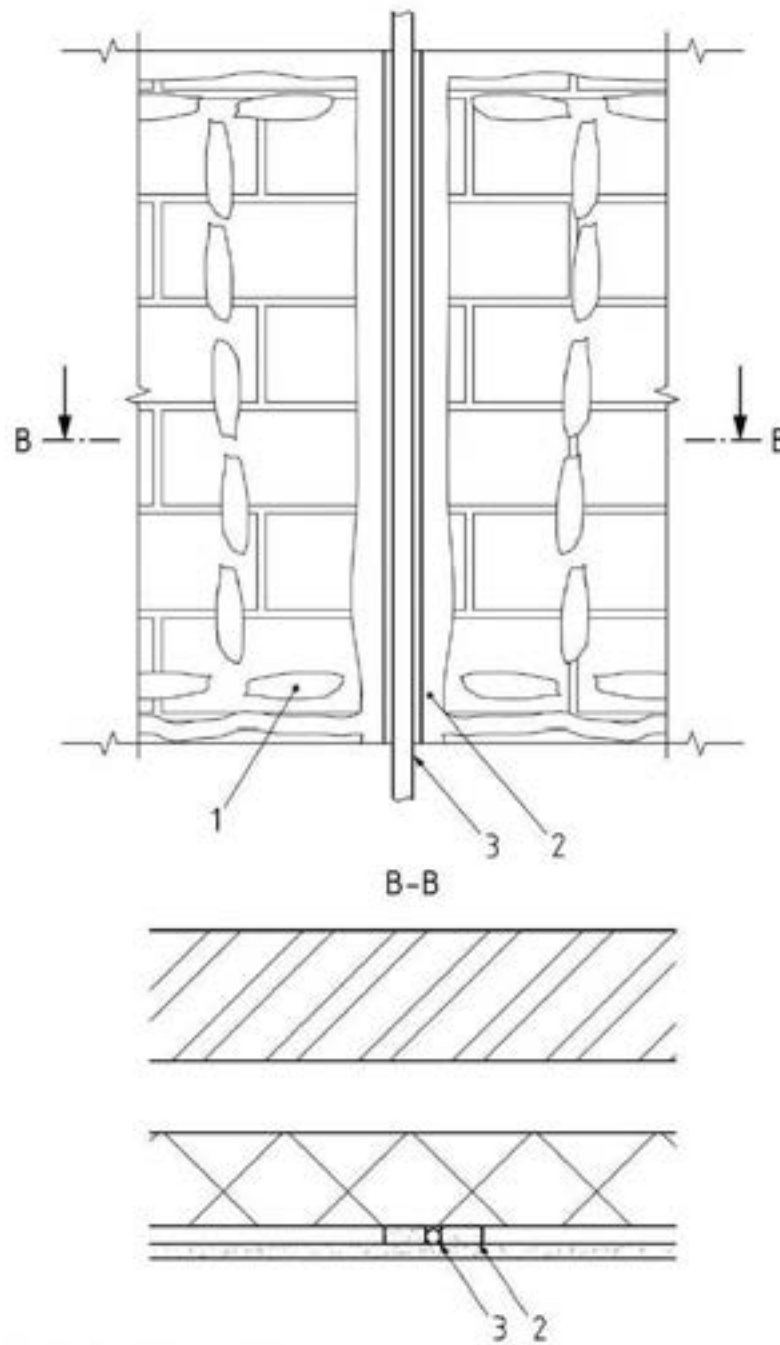

b) Brick and block with dry lining on dabs

Key

- 1 Individual adhesive dabs
- 2 Continuous adhesive dabs to surround pipework
- 3 Pipework

Figure 3C - Brick and Block Dry Lined on Battens

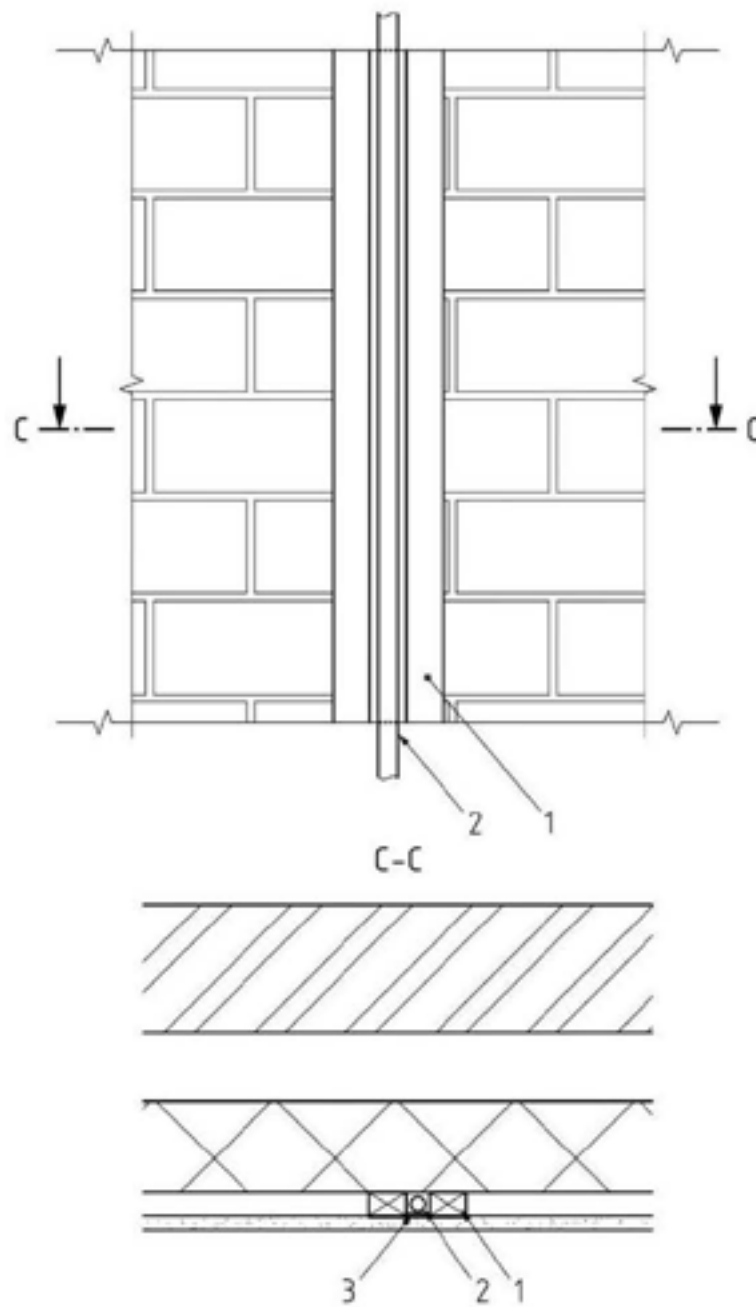

NOTE The joints between the wall and studs should be sealed with mastic in order to avoid gas tracking around the studs.

c) Brick and block dry lined on battens

Key

- 1 Timber battens
- 2 Pipework
- 3 Steel plate of min. 1 mm thickness

Figure 3D – Examples of Flexigas installed in timber and light steel framed construction walls

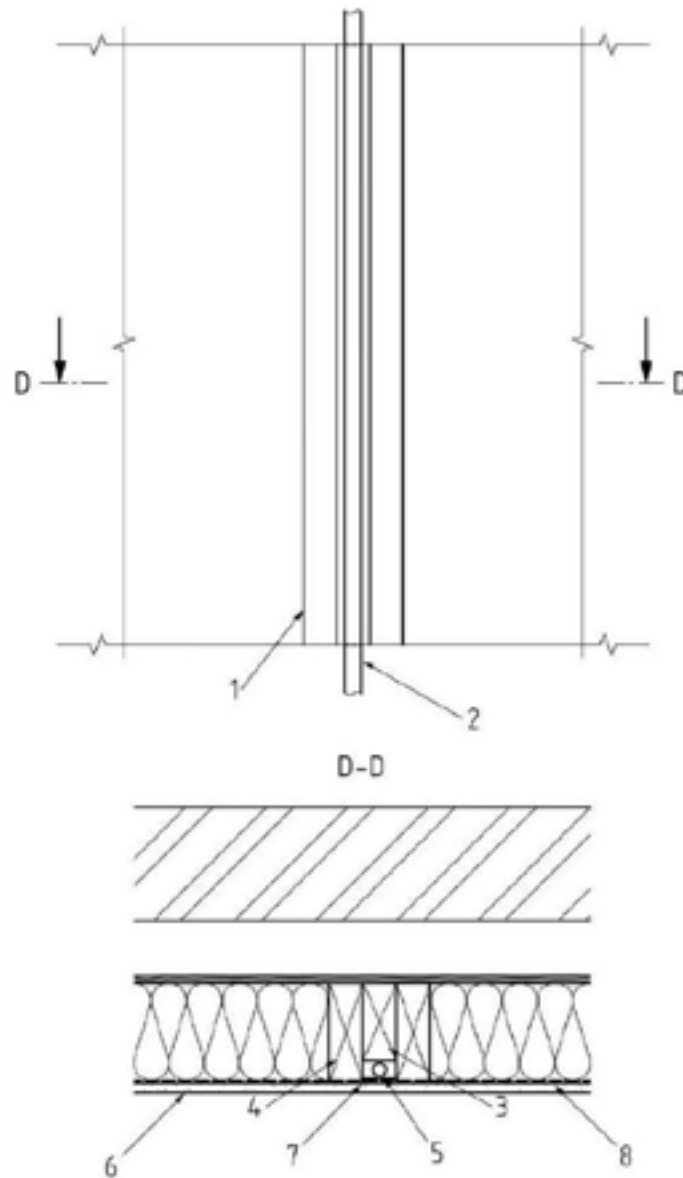

NOTE The joints between the studs should be sealed with mastic in order to avoid gas tracking around the studs.

a) Pipework passing through timber-frame wall

Key

- | | | | |
|---|----------------------------|---|------------------------------------|
| 1 | Timber stud | 5 | Pipework |
| 2 | Pipework | 6 | Plasterboard |
| 3 | Timber stud blocking piece | 7 | Steel plate of min. 1 mm thickness |
| 4 | Timber stud | 8 | Vapour barrier |

Figure 3E – Examples of Flexigas installed in timber and light steel framed construction walls

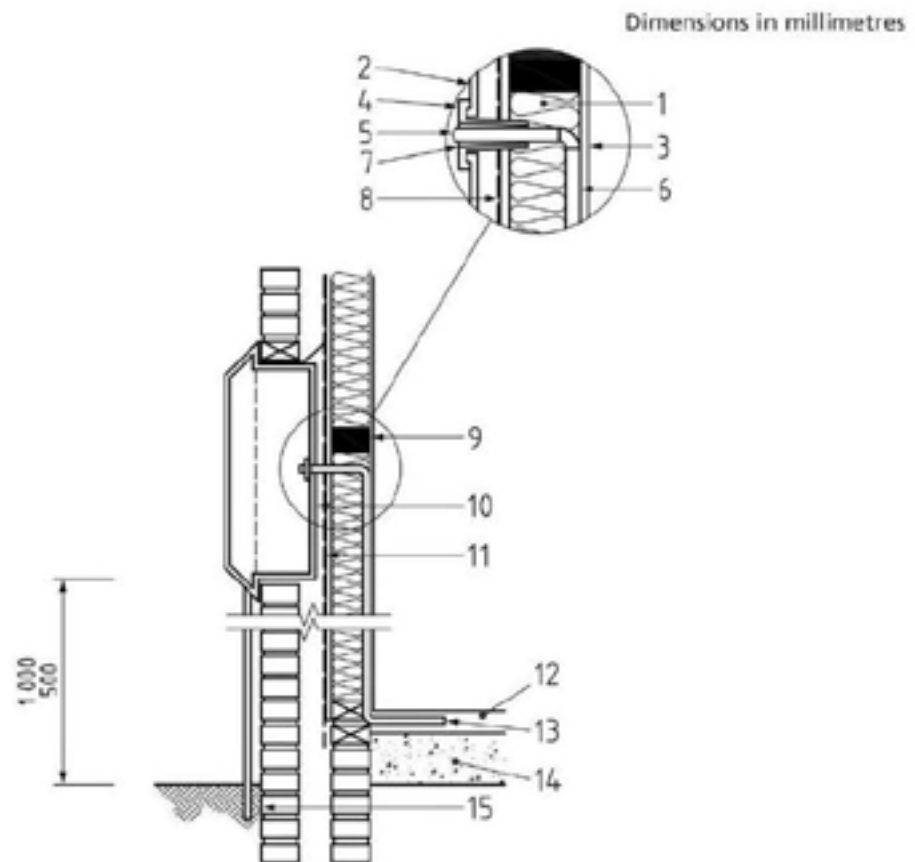

c) Pipework entering a timber-framed/light steel-framed building from a meter box

Key

- | | | | |
|---|---|----|--|
| 1 | Insulation | 10 | Air space between back of box and breather membrane |
| 2 | Meter box wall | 11 | Breather membrane carried down behind meter box |
| 3 | Plasterboard | 12 | Floor screed |
| 4 | Rear spigot | 13 | Pipework from meter notched through sole plate
Preservative treatment to sole plate made good |
| 5 | Pipework (protected by a steel plate of min. 1 mm thickness as necessary) | 14 | Concrete |
| 6 | Vapour control layer | 15 | Service pipe or service pipework, as appropriate |
| 7 | Mastic sealing | | |
| 8 | Timber sheathing | | |
| 9 | Timber stud | | |

Figure 3F – Examples of Flexigas installed in timber and light steel framed construction walls

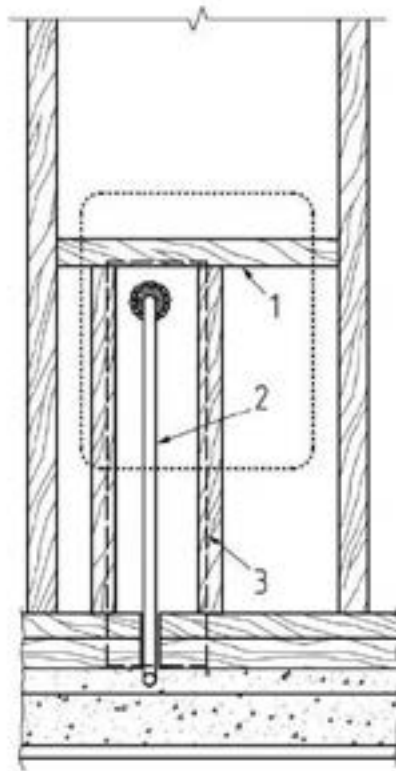

NOTE The joints between the studs should be sealed with mastic in order to avoid gas tracking around the studs.

b) Pipework installed in a timber-framed wall

Key

- 1 Timber stud
- 2 Pipework
- 3 Steel plate of min. 1 mm thickness

Figure 3G– Typical method of accommodating movement though a masonry/timber frame wall

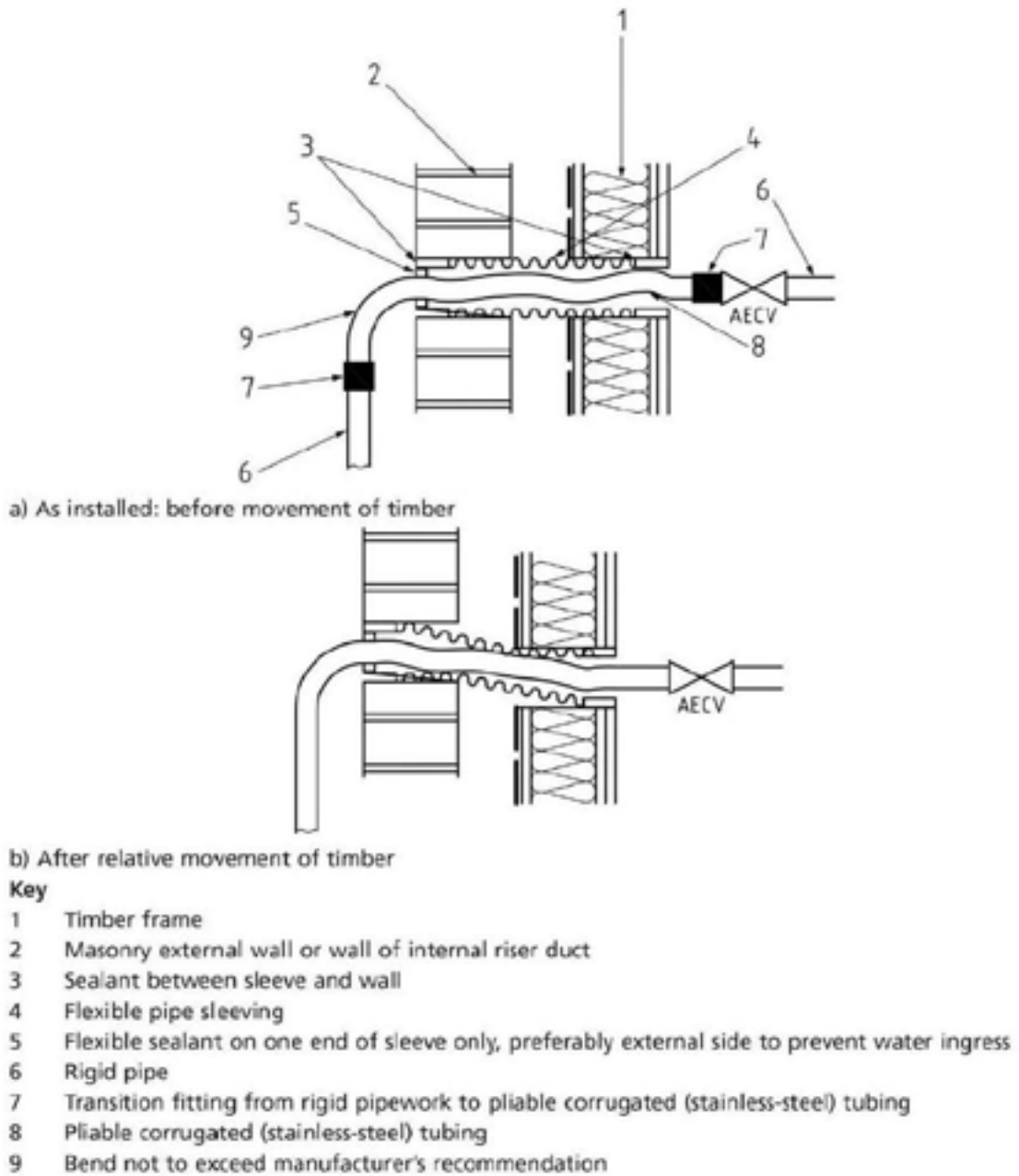

14 – SLEEVES

Sleeves shall be of a material capable of containing gas, e.g. copper, steel, polyethylene (PE) or polyvinyl chloride (PVC).

Before Flexigas tubing is passed through the sleeve the installer should check the yellow plastic cover of the Flexigas tubing for any gaps or holes in the cover. Any holes should be covered with silicone tape with at least 50% cover on each subsequent pass of the tape.

Pipework passing through a wall or a floor, whether or not it contains a cavity, shall pass through sleeve.

Sleeves shall pass through the full width of the wall or the full thickness of the floor. Sleeves shall not impair the fire resistance of a building. The annular space between the pipe and the sleeve shall be sealed at one end to the pipe with a flexible fire resistant compound. Where a sleeve passes through an exterior wall, the seal shall be on the inside of the wall.

The internal diameter of any sleeve should allow for an annular space around the pipe to enable satisfactory insertion of the pipe into it and be of sufficient diameter to allow adequate sealing between the pipe and the sleeve.

Flexigas fittings shall not be located within the sleeve.

The outside of the sleeve shall be secured and sealed at each end to the structure of the building with a suitable building material, e.g. cement mortar.

15 – FLEXIGAS IN DUCTS

Vertical and horizontal ducts containing Flexigas tubing are required to be ventilated to ensure that minor* gas leakage does not cause the atmosphere within the duct to become unsafe.

The duct may run freely through a number of storeys or take the form of an enclosure at each storey level. Where ducts are continuous, ventilation can normally be achieved by the provision of openings sized in accordance with the table below. Where the duct takes the form of an enclosure at each storey level, ventilation is normally required at high level only in each storey (see Figures 4A & 4B).

The following table gives ventilation requirements for different duct sizes.

<u>Cross sectional area of duct (m²)</u>	<u>Minimum free area of each opening (m²)</u>
Not exceeding 0.01	0
0.01 and not exceeding 0.05	Cross sectional area of duct
0.05 and not exceeding 7.5	0.05
Exceeding 7.5	1/150 of the cross sectional area of the duct

Please Note:

Ducts having a small cross sectional area and volume (i.e. 0.01m² or less with a total volume of less than 0.1m³) are considered to be adequately ventilated by adventitious means and no additional openings are required.

Flexigas tubing may be installed in an unventilated duct where it is sleeved as per Section 14. Flexigas should not be placed in any metallic duct or chase that includes a metallic appliance vent or chimney that protrudes through or past the roof.

The normal minimum period of fire resistance of the duct is 30 min for buildings of not more than three storeys. Further guidance on the fire resistance of buildings is given in the appropriate Building Regulations. The fire resistance of any duct containing Flexigas shall have a fire rating equal to or greater than any void through which it passes.

*Minor gas leakage is that which would remain undetected by normal gas tightness testing techniques. The level of ventilation is not intended to clear a major gas escape arising from damage or failure of a gas pipe.

16 - FIRE PROTECTION/STOPPING

For buildings containing flats and/or maisonettes, Flexigas installations shall be fire stopped as they pass from one floor to another unless in their own protected shaft that is ventilated top and bottom to outside air.

When installation pipes from a continuous duct enter a flat or maisonette they shall be fire stopped at the point of entry.

Examples of typical installation pipework in multi storey buildings containing flats or maisonettes are given in Figures 4A & 4B.

Best Practice In Regards To Fire Stopping

When pipes pass through the protecting structure (i.e. compartment walls or floors) all openings should be kept as small, and as few in number, as practicable, and should be suitably fire stopped in such a manner as to allow thermal movement of the pipe and ensure the fire resistance is not impaired. To prevent displacement, materials used for fire stopping should be supported by, or reinforced with, materials of limited combustibility. Any proprietary fire stopping should, when tested in accordance with the appropriate part of BS 476, achieve the relevant periods of fire resistance for the structure in respect of load bearing capacity, integrity and insulation.

Figure 4A - Typical installation pipework in multi storey buildings containing flats or maisonettes – Ventilated duct.

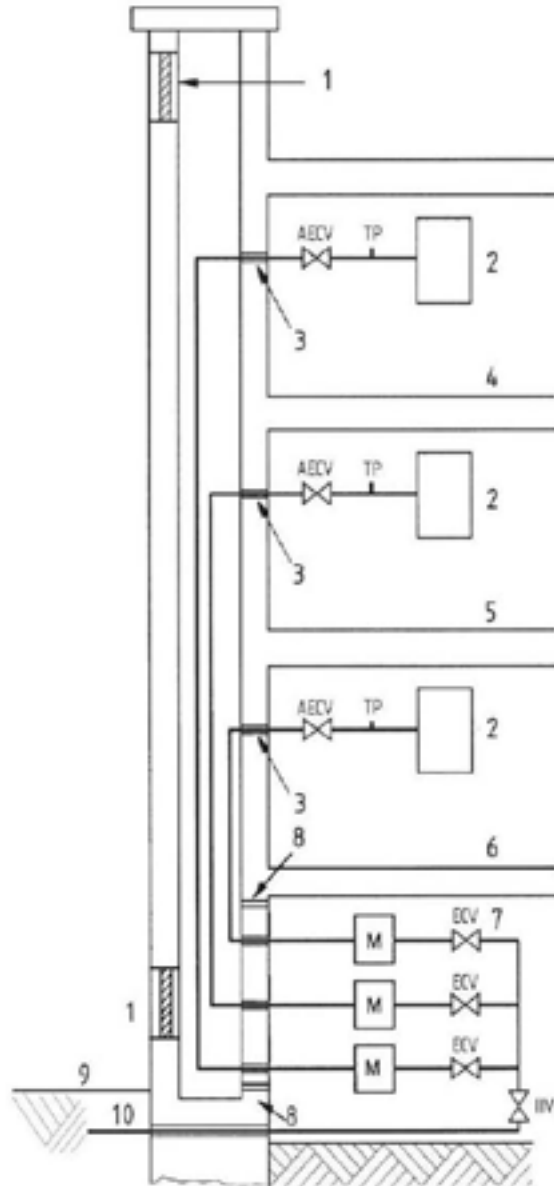

Key

- 1 = Ventilation
- 2 = Appliance
- 3 = Fire stop
- 4 = Flat 3
- 5 = Flat 2
- 6 = Flat 1
- 7 = Meter room
- 8 = Meter room ventilation

- 9 = Ground level
- 10 = Gas service
- ECV = Emergency control valve
- AECV = Additional emergency control valve
- IV = Inlet isolation valve
- M = Gas meter
- TP = Test point

Figure 4B - Typical installation pipework in multi storey buildings containing flats or maisonettes – Fire stopped pipework and a ventilated enclosed area.

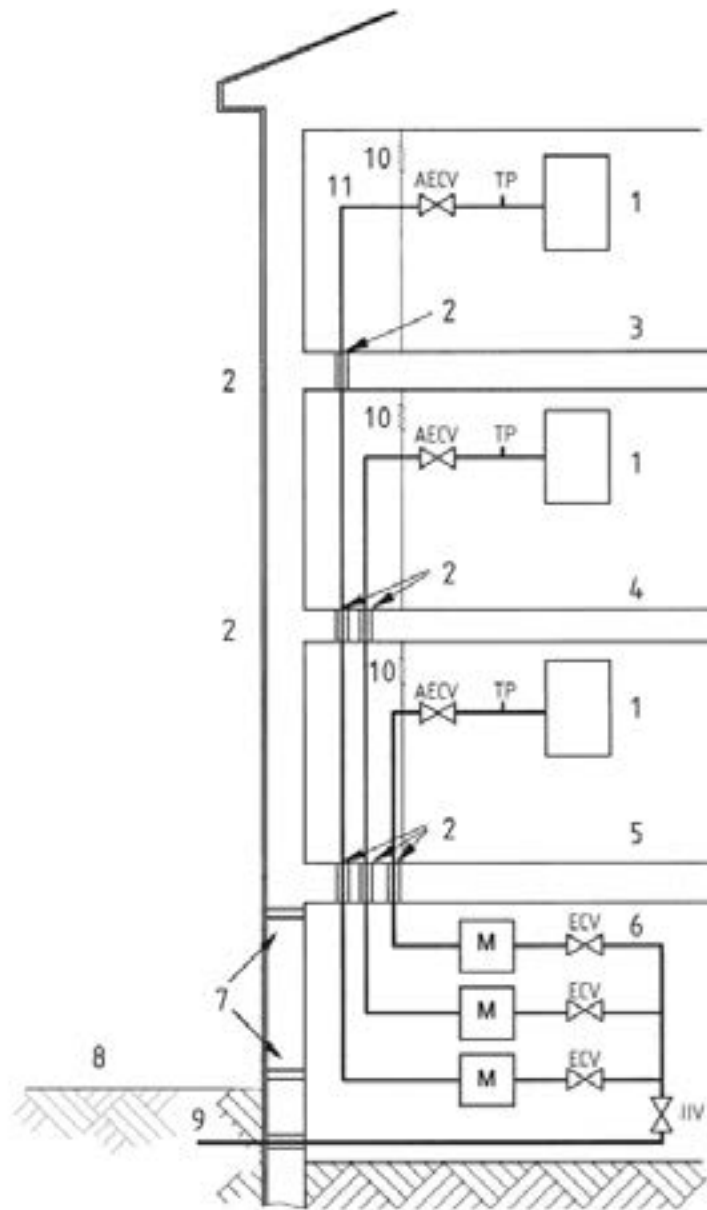

Key

- 1 = Appliance
- 2 = Fire stop
- 3 = Flat 3
- 4 = Flat 2
- 5 = Flat 1
- 6 = Meter room
- 7 = Meter room ventilation
- 8 = Ground level

- 9 = Gas service
- 10 = Vent
- 11 = Enclosure
- ECV = Emergency control valve
- AECV = Additional emergency control valve
- IIV = Inlet isolation valve
- M = Gas meter
- TP = Test point

17 - PIPE SUPPORTS

Flexigas CSST tubing should be supported by the following maximum distance between pipe supports.

Nominal Size	Vertical Run	Horizontal Run
DN15	1.2m	1.2m
DN22	1.8m	1.8m
DN28	1.8m	1.8m
DN32	2.5m	2.5m

18 - EXTERIOR PIPEWORK

Flexigas can be buried under soil. Where Flexigas is installed underground the user should check the cover for any holes or gaps and cover with self adhesive silicone tape with at least 50% per pass (to ensure a double layer) to prevent corrosion from the surrounding soil.

Flexigas installed in soil, gardens or under areas with no vehicular traffic shall have at least 375mm of cover. Flexigas installed below drives with light vehicular traffic shall be at least 400mm & for drives with heavy traffic shall be at least 600mm.

For more information on how to bury all gas pipework including Flexigas please see BS6891:2015 section 8.9

Flexigas may not be installed under buildings. Flexigas fittings shall not be installed below ground. Flexigas is suitable for use where it is exposed. The cover is UV stable and as such no further protection or labelling is not required. As above, the installer should check to ensure there are no holes in the protective layer. The user shall also ensure that the gap between the cover and the fittings is properly covered with self-adhesive tape.

For commercial or LPG installations please consult the relevant standards. Examples of typical exterior pipework is shown in Figure 5

Figure 5 - Typical exterior pipework with 375mm cover

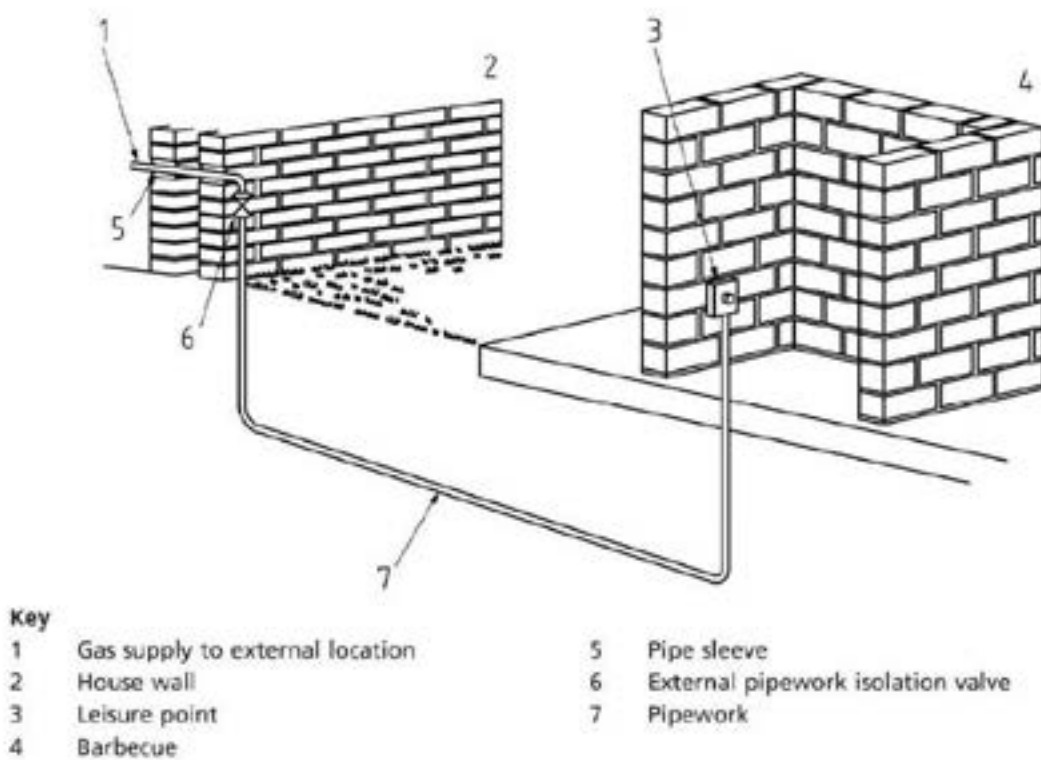

Figure 5 - Typical exterior pipework with 375mm cover

19 - INTERRELATION WITH OTHER SERVICES

Installation pipework shall be located or electrically insulated so that it does not touch metallic fittings which can give rise to electrolytic corrosion. The Flexigas polyethylene cover and silicone tape should provide adequate protection where spacing is impracticable.

Where installation pipework is not separated by electrical insulating material, they shall be spaced as follows:

- at least 150mm away from electricity meters and associated excess current controls, electrical switches or sockets, distribution boards or consumer units;
- at least 25mm away from electricity supply and distribution cables.

Care shall be taken not to damage any electrical conductor when installing pipework.

Installation pipes shall not be buried in floors together with electrical underfloor heating, unless the underfloor heating has been physically and permanently disconnected.

20 - MAIN EQUIPOTENTIAL BONDING

All domestic gas installations (including CSST systems such as Flexigas) shall have main equipotential bonding of the gas installation pipework conforming to BS 7671.

The purpose of electrical bonding is to create a zone in which voltage differences, and therefore hazards from electric shocks, are minimized. This is achieved by connecting separate conductive components together with a main equipotential bonding conductor or metal pipework. If an electrical fault occurs, either inside or outside of a building, it is possible for stray currents to be transmitted through the gas installation pipework.

With a PME (protective multiple earth) system, a small current may pass along the pipework under normal conditions. Therefore, to avoid electric shock, or a spark which could ignite the gas, it is important to maintain electrical continuity in the pipework at all times.

Main equipotential bonding shall be connected:

- as near as practicable to the point of entry into premises;
- before any branch in the installation pipework;
- in a position where it is accessible, can be visually observed, and fitted with a warning label stating "Safety electrical connection. Do not remove.";
- by a mechanically and electrically sound connection which is not subject to corrosion.

The main protective bonding conductor must not be attached to the Flexigas tubing (i.e. the stainless steel tubing) directly (nor any flexible connector that may be in use near the meter).

Main equipotential bonding of the gas installation pipework should be made using cable with minimum cross-sectional area of 10 mm² cable with green and yellow insulation, construction reference 6491X conforming to BS 6004.

For internal meters, for verification purposes the bonding connection should be within 600 mm of the meter outlet.

MAIN EQUIPOTENTIAL BONDING

Most electrical installations are required to be fitted with main equipotential bonding, which consists of the electrical connection of the internal gas and water pipes to the installation's main earthing terminal in accordance with the requirements of BS 7671. The gas installation pipe fitted in your premises does not appear to be bonded to the electrical installation. I am required by The Gas Safety (Installation and Use) Regulations 1998 to tell you that any necessary main equipotential bonding should be carried out by a competent person. I advise you to have this checked by an approved electrical contractor, i.e. a member of the National Inspection Council for Electrical Installation Contracting (NICEIC).

If you are the tenant of this property, would you please bring this matter to the attention of the owner or his agent as soon as possible.

Figure 6 - Position of main equipotential bonding connection

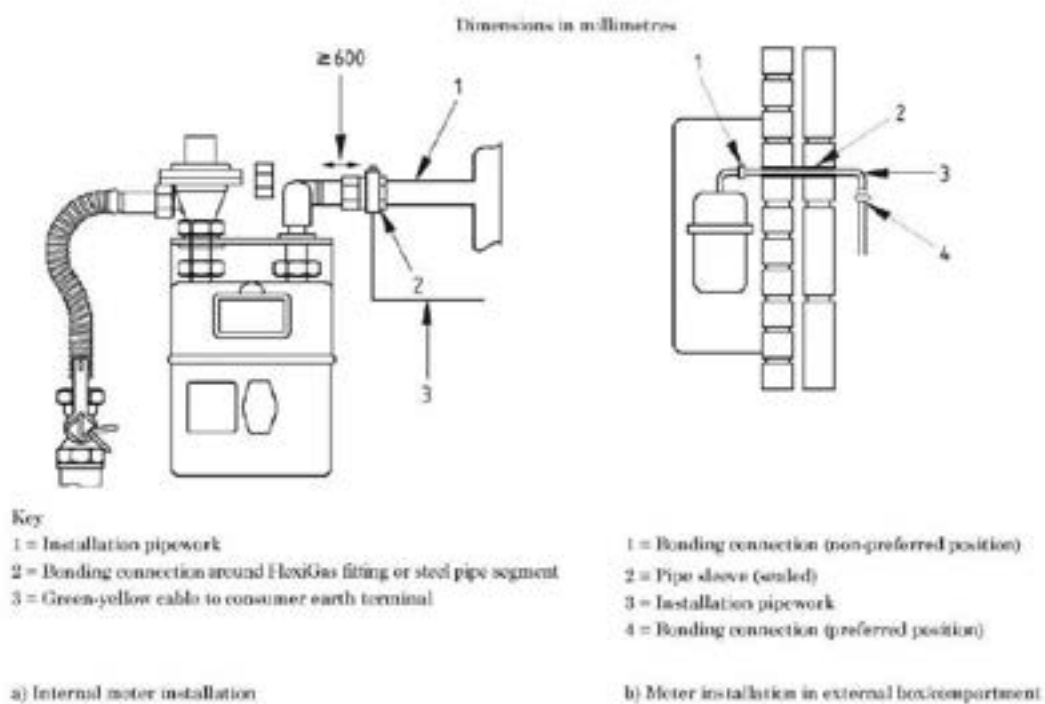

21 - VALVES (EMERGENCY CONTROL VALVES)

An Emergency Control Valve (ECV) should always be fitted. An ECV is not part of the installation pipework. It is usually installed at the end of the service main at the inlet of the primary meter.

An additional emergency control valve (AECV) shall be fitted:

- to the installation pipe where it enters the building if the meter is sited 6 m or more away from the building; or
- inside individual flats served by a large single or multiple meter installation located in a remote or communal area (see also Section 16 - Fire Stopping).

Every AECV shall:

- be labelled or marked to show its open and closed position;
- be fitted in an accessible position;
- be easy to operate;
- be fitted with a suitable handle which is securely attached, or other permanent means of operation;
- where the lever moves in the vertical plane, move to the "off" position in a downward direction.

On every AECV there shall be a permanent notice attached to the valve giving the following information:

- the valve is an "emergency control for customers' use";
- details of the parts of the installation isolated by the valve;
- the telephone number of the Gas Emergency Service; and
- advice to the customer on actions to be taken if they think they can smell gas.

A pressure test point shall be installed no more than 300 mm downstream of the AECV.

Where the installation pipe is taken from inside a building to supply an appliance situated externally, a valve shall be installed in an accessible position where the installation pipe leaves the building. It is preferable that the valve be fitted externally.

22 - PREVENTION OF CORROSION

Flexigas shall not be installed in a position where it is likely to be exposed to a corrosive environment. The Flexigas yellow cover will provide adequate protection against corrosion in the majority of installation environments. The installer however must take special care to ensure that all exposed parts of the stainless steel are adequately protected either by means of the cover or by wrapping with silicone tape. Any exposed stainless steel around the fitting should be wrapped with self bonding silicone tape, as should any gaps or holes in the plastic cover, to ensure that no stainless steel is exposed.

Assembled pipework should be tested for gas tightness (in accordance with Section 23 before any additional protection against corrosion is applied on site.

Special care should be taken to check the integrity of the cover when burying the pipework with any gaps or holes wrapped with at least 50% overlap. This should be done after performing the gas tightness test.

When applying the tape ensure the pipe is clean and dry. A minimum of 50 % overlap should be used when wrapping the pipe to provide a layer of at least double thickness.

Where possible, wrapping should be coloured yellow ochre in accordance with BS 1710.

Pipework In Fireplace Openings

CSST such as Flexigas are not suitable for use in the openings of all-fuel fireplaces as Soot and debris can be particularly corrosive. Flexigas being used in such a scenario must be terminated outside the firebox with the final installation being made with a suitably protected pipe.

23 - GAS TIGHTNESS TESTING AND PURGING

Upon completion of the installation and prior to gas being made available, the installation shall be tested for gas tightness and purged in accordance with IGE/UP/1B – Tightness testing and purging of domestic sized natural gas installations (or other applicable standard).

Self-bonding silicone tape should only be applied to any gaps/holes on the cover, and to the area around the fittings after the gas tightness testing has been conducted.

Some leak detection fluids may be corrosive to the components of Flexigas (i.e. stainless steel and brass) and should not be used. In particular chemicals with a high chloride content (such as soaps) should be strictly avoided.

Whenever a gas supply system is being commissioned or re-commissioned it must be purged of air as per IGE/UP/1B. This includes conducting a tightness test as above.

24 - CONNECTION OF FLEXIGAS TO OTHER SYSTEMS

The Flexigas system can only be connected to other piping systems by means of approved BSP thread fittings.

Flexigas tubing is only compatible with Flexigas fittings. No Flexigas components should ever be connected directly with any other CSST systems despite how similar they may appear.

Where soldered components are to be joined to Flexigas (by means of a thread fitting) the solder work should be done well before any Flexigas component is brought within the vicinity of where the connection is to be made. Before attaching the Flexigas fitting ensure that the corresponding thread is cleaned, dry and free from any solder flux residue.

25 - DAMAGE AND REPAIR

Despite its weight Flexigas is quite resilient. However, the installer should still take special care not to damage the components of the system, either in storage or installation.

Where damage has occurred to the cover, it can be repaired by use of self bonding silicone tape. The tape should be wrapped around the pipe so that there is at least 50% overlap from one pass of the tape to the next. Any damage to the cover should be repaired after gas tightness testing.

Where damage to the tubing has occurred the damaged piece of tube should be removed from the pipe run. A section of tubing should be replaced where:

- The tubing has been punctured (i.e. by a nail, drill, screw)
- The tubing has been bent beyond its minimum bend radius.
- The tubing has been significantly crushed to the point where it will restrict flow.
- The tubing has been exposed to a corrosive chemical or material.

Where damage occurs in a pipework section where fittings are not permitted (i.e. in section of tubing that is to be placed in the ground or a wall) it will be necessary to replace the whole tubing run, or at least take the tubing run back to a location where fittings are permitted.

If the damaged section of tubing occurs in a portion of the pipework where fittings are permitted then it will be possible to repair the tubing run by removing the damaged component and joining the two sections of tubing together by use of a Flexigas Union fitting. The installer should be careful however not to put excessive strain on other parts of the pipework when trying to join these sections together. Where a larger section of Flexigas tubing has been damaged, the damaged section can be replaced by use of two Flexigas Union fittings and an additional piece of Flexigas tubing.

26 – WARRANTY

FlexiGasUK Ltd warrants that all components of the FlexiGas™ system are free from defects and that if any such defect should be discovered a replacement component will be provided up to 25 years from the date of purchase. This warranty is limited to making a replacement component available and does not include or cover any labour cost involved or connected therewith (including but not limited to diagnosing the defective component and/or removing and reinstallation of said defective component).

This warranty does not apply to any defective component that is considered unfit for purpose or defective due to improper installation, storage, transportation or general misuse (either through negligence or otherwise), nor does this warranty extend to any loss or damage caused by events outside the direct control of FlexiGasUK Ltd (including but not limited to improper storage or transportation, floods, fires and other acts of God). This warranty is in lieu of any other warranties expressed, implied or statutory.

27 - PIPE SIZING (INCLUDING EXAMPLE)

At the initial stages of design and planning a gas installation the designer/installer should verify that the installation pipes will be adequate for both immediate and probable future requirements, in particular where the pipe is to be buried or will be hard to access.

For domestic natural gas installations it is recommended practice to allow a maximum pressure loss of 1 mbar between the meter outlet and the appliance connection points. The pressure at the meter should be 21mbar (BS 6891). Low pressure 3rd family gas supplies should be regulated at 28mbar (butane) & 37mbar (propane) with a pressure drop not exceeding 2.5mbar (BS 5482).

Installers should also note that fittings can disrupt the discharge rates given in the sizing tables (which are for a straight horizontal run). Installers should add the following equivalent tubing lengths when estimating what size tube to use.

	90° bend	Tee (through flow)	Tee (diverted flow)	Coupling (male/female/union)
DN15	0.15m	0.25m	0.80m	0.25m
DN22	0.20m	0.25m	0.80m	0.25m
DN28	0.25m	0.20m	0.90m	0.20m
DN32	0.30m	0.20m	0.90m	0.20m

Installers should note that the discharge rates in the following tables are approximate and that a number of factors can affect the discharge rates in use (for example arcs in the tube not counted as 90° bends). Installers should make sure that the size of the pipe selected be of sufficient diameter to easily supply all the appliances on the installation when they are used at the maximum gas rate, plus allow for future appliances to be added that may have a higher gas rate (such as a larger gas boiler).

Figure 7 gives an example of a Flexigas domestic gas installation showing the lengths of pipes and the gas rates of the appliances.

When sizing pipes, it is essential that consideration is given to the permissible pressure loss in each section of the installation. For example, the pressure loss between A and H in Figure 7 should not exceed 1 mbar.

A to H is made up of four sections of pipe, A-B, B-D, D-F and F-H. Each section carries a different gas rate and needs to be sized separately.

If A to H is to have a pressure loss of not more than 1 mbar, then the pressure losses in each of the four sections should be approximately 0.25 mbar. So A-B, B-D, D-F and F-H should each be sized to give a pressure loss of approximately 0.25 mbar.

The table of discharges in a straight horizontal pipe given in Table 1 only allows for pressure losses of 1mbar. However, pressure loss is proportional to length, so if the pipe size selected in Table 1 is four times longer than required, the pressure loss on the actual length will be 0.25mbar.

Working Example

Considering length D–F as given in Figure 7:

- D–F has a length of 1.5m and is to carry a gas rate of 1.5m³/h (for the cooker and the gas fire); it should have a pressure loss of 0.25mbar maximum.
- It also includes one tee fitting in the calculation (at point 4 – undiverted), and so 0.25m should be added to the equivalent length.
- A pressure loss of 0.25mbar in a length of 1.75m = 1 mbar in 7m (4 x 1.75m)
- In Table 1, look up the information for the closest unit to 7m. It is noted that 7.5m of Flexigas DN22 will discharge approximately 4m³/h & 5m of Flexigas DN22 approximately 4.75m³/h. The discharge rate for 7m will be between the two.

Thus the DN22 tubing gives a sufficient flow rate to carry the 1.5 m³/h of gas and allows a significant margin for major appliances to be added to the installation at a later date.

Figure 7 – Example Of A Pipe Sizing Calculation

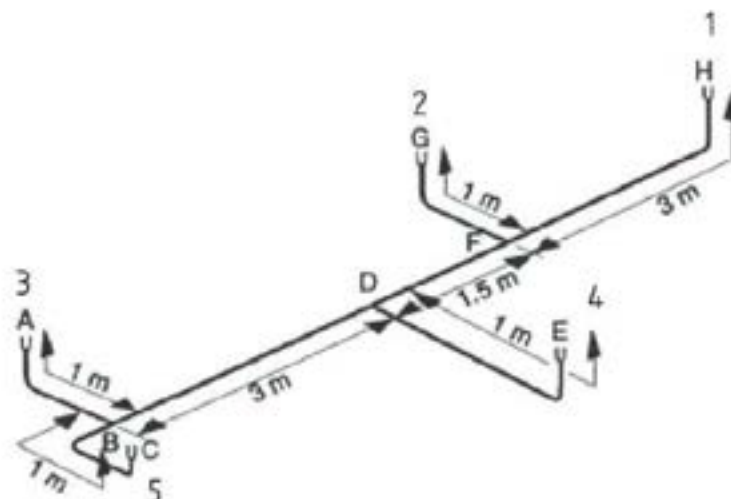

Appliance	Gas rate (typical) m ³ /h
Warm air unit	1.0
Multi-point water heater	2.5
Cooker	1.0
Gas fire	0.5
Central heating boiler	1.5
Combination boiler	2.5

Key

1 = Fire

2 = Cooker

3 = Meter

4 = Multi-point water heater

5 = Warm air unit

28 – SIZING TABLES

TABLE 1

NATURAL GAS - Approximate discharge (m³/h) through a a straight horizontal run of Flexigas. (specific gravity = 0.6, pressure drop between ends = 1 mbar)

Metres	DIN Size			
	15	22	28	32
1	4.60	9.30	20.00	32.00
2.5	2.70	6.60	12.00	22.00
5	1.60	4.75	8.50	16.00
7.5	1.30	4.00	6.90	12.90
10	1.05	3.50	6.00	11.50
15	0.85	2.85	4.90	9.20
20	0.70	2.50	4.25	7.90
25	0.55	2.30	3.80	7.10
30	0.55	2.00	3.50	6.50
40	0.50	1.80	3.00	5.50
50	0.40	1.60	2.70	5.00
60	0.40	1.50	2.50	4.60
70	0.30	1.40	2.30	4.25
80	0.30	1.30	2.15	4.00
90	0.30	1.20	2.00	3.80
100	0.30	1.15	2.00	3.50

28 – SIZING TABLES

TABLE 2

PROPANE - Approximate discharge (m³/h) through a a straight horizontal run of Flexigas
(specific gravity = 1.52, pressure drop between ends = 2.5mbar)

Length	DIN Size			
	15	22	28	32
2.5	2.50	6.10	18.00	19.00
5	1.80	3.80	11.00	14.00
7.5	1.50	3.20	6.60	11.00
10	1.25	2.90	5.85	9.50
15	1.00	2.30	4.80	8.50
20	0.80	2.00	4.20	7.55
25	0.70	1.90	3.75	7.00
30	0.65	1.75	3.45	6.50
40	0.60	1.55	3.00	5.25
50	0.51	1.55	2.70	5.00
60	0.45	1.25	2.50	4.50
70	0.40	1.20	2.30	4.00
80	0.30	1.10	2.20	3.75
90	0.30	1.00	2.00	3.50
100	0.30	0.90	1.90	3.50

28 – SIZING TABLES

TABLE 3

BUTANE - Approximate discharge (m³/h) through a a straight horizontal run of Flexigas
(specific gravity = 2.07, pressure drop between ends = 2.5mbar)

Length	DIN Size			
	15	22	28	32
2.5	2.00	4.50	9.80	15.00
5	1.50	3.20	7.25	12.00
7.5	1.20	2.65	5.70	9.50
10	1.00	2.30	5.30	8.50
15	0.85	2.00	4.15	7.50
20	0.75	1.75	4.00	6.50
25	0.65	1.60	3.20	5.80
30	0.60	1.50	2.95	5.25
40	0.60	1.40	2.55	4.30
50	0.50	1.30	2.30	4.00
60	0.50	1.20	2.10	3.75
70	0.40	1.10	1.95	3.25
80	0.40	1.00	1.80	3.00
90	0.40	0.90	1.70	3.00
100	0.40	0.85	1.60	2.75

Flexigas

☎ 01625 877 222

info@Flexigas.com or visit Flexigas.com
Unit 1 Armcon Business Park
London South Road, Poynton, SK12 1LQ