

**JOHANSON**  
TECHNOLOGY 

**JOHANSON**  
DIELECTRICS 

Shortform 2019

Official Distributors for  
Australia and New Zealand



[fairmontmarketing.com.au](http://fairmontmarketing.com.au)



[dlpc.com.au](http://dlpc.com.au)

# High Voltage MLCC Capacitors

## Space Saving, High Quality

Johanson Dielectrics high voltage MLCC capacitors feature a special internal electrode design which reduces voltage concentrations by distributing voltage gradients throughout the entire capacitor. This unique design also affords increased capacitance values in a given size and voltage rating. The high voltage MLCC capacitors are designed and manufactured to the general requirement of EIA198 and are subjected to 100% electrical testing making them well suited for a wide variety of telecommunication, commercial, and industrial applications.



## Features

- Wide range of available case sizes, voltages, and capacitance ranges
- Available in both NP0 (C0G) and X7R dielectrics
- Can be supplied with a variety of terminations including Tin, Tin/Lead, and others
- BME and PME constructions
- Polyterm soft terminations available
- DC voltages available from 250 through 6KV

## Benefits

- Allows greater board density rates compared to Through Hole Capacitors
- RoHS complaint parts
- Polyterm terminations greatly reduce damage from assembly operations
- Not susceptible to cleaning damage as is the case with many film capacitors
- Ease of assembly as parts are not polarized

## Applications

Markets	End Product Applications
<b>Telecom and Network</b>	HV Isolation Surge Protection Network Interface EMI Suppression
<b>Lighting Emitters &amp; Controls</b>	LED Drivers CFL Blast HID
<b>Ethernet Connectors</b>	RJ-45 Isolation
<b>Power Supplies</b>	Input Filter Voltage Multiplier Isolation EMI Suppression
<b>Industrial</b>	Variable Speed Drive Motor Controls EMI Filter
<b>Consumer Electronics</b>	HV Isolation EMI Suppression Surge Protection
<b>Medical</b>	Voltage Dividers HV Isolation Surge Protection

## Ordering Information

Example P/N: **202R18W102KV4E**

Voltage	Size	Dielectric	Capacitance	Tolerance	Termination	Marking	Packaging
<b>202</b>	<b>R18</b>	<b>W</b>	<b>102</b>	<b>K</b>	<b>V</b>	<b>4</b>	<b>E</b>
501 = 500V	R15 = 0805	N = NP0	102 = 1000pF	J = ±5%	V = NI Barrier with 100% Sn Plating (Matte)	4 = Unmarked	E = Embossed 7"
631 = 630V	R18 = 1206	W = X7R	104 = 0.10 µF	K = ±10%	F = Polytherm Flexible Termination	6 = EIA Code	T = Punched 7"
102 = 1000V	R29 = 1808		1st two digits are significant; third digit denotes number of zeros	M = ±20%	T = SnPb		No code = bulk
202 = 2000V	S41 = 1210						Tape specs per EIA RS481
302 = 3000V	S43 = 1812						
402 = 4000V	S47 = 2220						
502 = 5000V	S48 = 2225						
602 = 6000V	S49 = 1825						

# UL/TUV AC Safety MLC Capacitors

## Supplying High Performance and Reliable Capacitors Over 20 Years

UL/TUV AC Safety MLC Capacitors are available in NPO and X7R dielectric materials. Johanson Safety Capacitors (Type SC) are both UL and TUV certified.

Johanson Type SC ceramic chip capacitors are designed for AC voltage surge and lightning protection in line-to-ground interface applications in HID, LED lighting drivers, computer networks, industrial equipment and many other applications.

Available in four different case sizes, these devices are surface mount ready with tape and reel packaging.

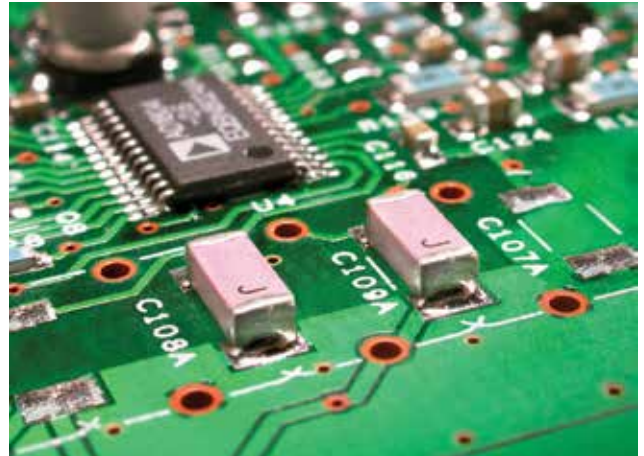

### Features

- X2/Y3, Y3 (2,500V impulse certified) and X1/Y2, Y2 (5,000V impulse certified) versions available
- Product certifications include TUV Rhineland R 50227900, UL File E121609, and Semko 0026092-1 & 0003222-1 (dependent on product classification)
- Standards met include IEC 60384-14:2005, EN 60950 2001, and UL 60950-01
- Available in four different case sizes
- Available in both NPO and X7R dielectrics
- Wide range of available voltages and capacitance ranges
- Can be supplied with a variety of terminations including Tin over Nickel
- Polyterm soft terminations available
- Non-polarized parts

### Benefits

- Allows greater board density rates compared to Thru-Hole Capacitors
- RoHS compliant parts
- Polyterm terminations can reduce stresses from assembly operations and processing
- Not susceptible to cleaning damage as is the case with many film capacitors
- Ease of assembly through standard SMT processing

### Ordering Information

Example P/N: **302R29W102MV3E-\*\*\*\*-SC**

Voltage	Size	Dielectric	Capacitance	Tolerance	Termination	Marking	Packaging	Type
<b>302</b>	<b>R29</b>	<b>W</b>	<b>102</b>	<b>M</b>	<b>V</b>	<b>3</b>	<b>E</b>	<b>-****-SC</b>
302 = 250VAC [2500V Impulse]	R29 = 1808 R30 = 2211	N = NPO W = X7R	R = decimal 102 = 1000pF 104 = 0.10 μF 5R0 = 5.0 pF 1st two digits are significant; third digit denotes number of zeros	J = ±5% K = ±10% M = ±20%	V = Ni Barrier with 100% Sn Plating (Matte) F = Polyterm Flexible Termination	3 = Required Safety Mark	E = Embossed 7"SC = Safety No code = bulk Tape specs per EIA RS481	SC = Safety Certified

### Applications

Markets	End Product Applications
<b>Telecom and Network</b>	Surge Protection Network Interface EMI Suppression
<b>Lighting Emitters &amp; Controls</b>	LED Drivers CFL Blast HID
<b>Power Supplies</b>	Input Filter
<b>Industrial</b>	Variable Speed Drive Motor Controls
<b>Inverters</b>	EMI Suppression Control Boards for PV Inverters
<b>Consumer Electronics</b>	HV Isolation EMI Suppression Surge Protection
<b>Medical</b>	Voltage Dividers HV Isolation Surge Protection

# DC-DC Converter EMI Filter

## Reduce Switching Noise, Speed EMC Compliance

Johanson RFI Suppression Filter Chips feature proven, patented, X2Y® low noise architecture and are one of the most effective EMC filters available on the market today!

This EMI filter for DC-DC Converters has ultra-low parasitic inductance resulting in a broad filter stop-band. The dual line filter exhibits tightly matched impedance providing very low noise mode conversion, an unwanted characteristic that reduces the filtering of typical L-C filters or common mode chokes.

Noise mode conversion can be a “hidden enemy” in EMC filtering applications. Mode conversion is not specified by filter component vendors and defeats the commonly published 50Ω impedance.

A single X2Y outperforms common mode chokes and complicated multi-pole discrete filters, thus saving space and cost.

## Features

- Large noise reduction from Single Component
- 28:1 Amplitude Reduction
- Noise Reduction up to 41dBuV
- Low Conducted / Radiated Emissions
- NO CURRENT LIMIT due to Bypass Configuration
- Ultra-low ESL (Equivalent Series Inductance)
- Low Noise Mode-Conversion
- Tight Line-to-Line Impedance Matching
- Six Proto-typing Kits Available
- SPICE Models Available

## Benefits

- Reduced Compliance Testing accelerates time to market
- Superior Common-Mode Rejection
- Up to 17dB better noise mode-conversion than typical common-mode chokes
- Improved performance in both
- Conducted and Radiated Emission
- Replaces several discrete components overall smaller board footprint



## Applications

Markets	End Product Applications
<b>Automotive</b>	LED Lightning, Entertainment, Navigation, Body Controls
<b>IT</b>	Network Devices, Server POL, SFP Power
<b>Consumer</b>	Connected Home, Smart Grid Power Regulation, Kiosk Displays
<b>Industrial</b>	Process Controls, Analytical Test Equipment, LED Signs
<b>Medical</b>	Remote Patient Monitor Base, Medical Test Equipment

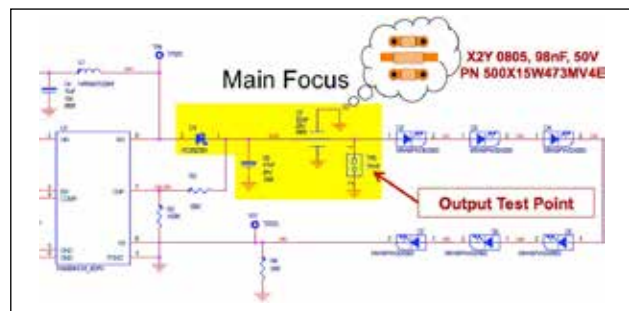

The test circuit where the waveform test data is measured on.

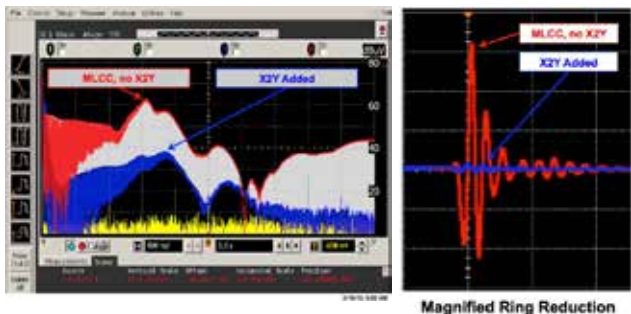

## Product Range

Capacitance	0400 (P17)	0400 (P17)	0400 (P17)	0400 (P17)	0400 (P17)	0400 (P17)	0400 (P17)	0400 (P17)	0400 (P17)	0400 (P17)	0400 (P17)	0400 (P17)	0400 (P17)	0400 (P17)	0400 (P17)	0400 (P17)	0400 (P17)	0400 (P17)	0400 (P17)	0400 (P17)
0400 (P17)	100nF	150nF	220nF	330nF	470nF	680nF	100nF	150nF	220nF	330nF	470nF	680nF	100nF	150nF	220nF	330nF	470nF	680nF	100nF	150nF
0600 (P14)	100nF	150nF	220nF	330nF	470nF	680nF	100nF	150nF	220nF	330nF	470nF	680nF	100nF	150nF	220nF	330nF	470nF	680nF	100nF	150nF
0805 (P13)	100nF	150nF	220nF	330nF	470nF	680nF	100nF	150nF	220nF	330nF	470nF	680nF	100nF	150nF	220nF	330nF	470nF	680nF	100nF	150nF
1206 (P18)	100nF	150nF	220nF	330nF	470nF	680nF	100nF	150nF	220nF	330nF	470nF	680nF	100nF	150nF	220nF	330nF	470nF	680nF	100nF	150nF
1210 (P18)	100nF	150nF	220nF	330nF	470nF	680nF	100nF	150nF	220nF	330nF	470nF	680nF	100nF	150nF	220nF	330nF	470nF	680nF	100nF	150nF
1810 (Q44)	100nF	150nF	220nF	330nF	470nF	680nF	100nF	150nF	220nF	330nF	470nF	680nF	100nF	150nF	220nF	330nF	470nF	680nF	100nF	150nF
1812 (Q43)	100nF	150nF	220nF	330nF	470nF	680nF	100nF	150nF	220nF	330nF	470nF	680nF	100nF	150nF	220nF	330nF	470nF	680nF	100nF	150nF

# EMI Suppression Filter

## Replaces DC Power Line Choke

Johanson EMI Suppression Filter Chips features X2Ys® proven, patented low noise architecture and are one of the most effective EMC filters available on the market today!

These EMI Suppression Filters feature ultra-low parasitic inductance resulting in a wide filter stop-band. These EMI filters have tightly matched impedance. Therefore, they exhibit very low noise-mode conversion, an unwanted characteristic that plagues series magnetic and discrete multi-component filter circuits.

Johanson EMI Suppression Filters are available in 0402 - 1812 sizes with rated voltages of 10 - 500 VDC.

### Features

- One Filter for Two DC Power Lines
- NO CURRENT LIMIT due to Bypass Configuration
- Ultra-low ESL (Equivalent Series Inductance)
- Low Noise Mode-Conversion
- Tight Line-to-Line Impedance Matching
- Six Proto-typing Kits Available
- SPICE Models Available

### Benefits

- Typical application savings: 50% cost, 80% size reduction.
- These EMI filters exhibit 17dB better noise mode-conversion than typical common-mode chokes.
- Noise mode-conversion is the “hidden enemy” in EMC filtering applications and a parameter that is not specified by filter component vendors.
- Lower noise mode-conversion results in huge improvement in both conducted and radiated emission performance.

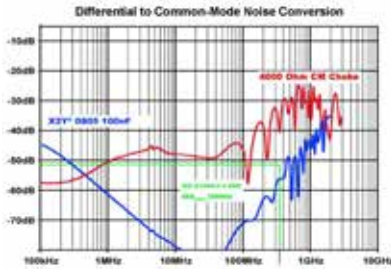

### Applications

Markets	End Product Applications
IT	Network Devices
Consumer	Audio
Industrial	Process Controls

### Product Range

Capacitance	0402	0603	0805	1206	1430	1812	0402	0603	0805	1206	1430	1812	0402	0603	0805	1206	1430	1812	0402	0603	0805	1206	1430	1812
SIZE	0402	0603	0805	1206	1430	1812	0402	0603	0805	1206	1430	1812	0402	0603	0805	1206	1430	1812	0402	0603	0805	1206	1430	1812
1000pF																								
100pF																								
10pF																								
100pF																								
1000pF																								

### Ordering Information

Example P/N: 101X14W102MV4T

Voltage	Size	Dielectric	Capacitance	Tolerance	Termination	Marking	Packaging
<b>101</b>	<b>X14</b>	<b>W</b>	<b>102</b>	<b>M</b>	<b>V</b>	<b>4</b>	<b>T</b>
6R3 = 6.3V	X07 = 0402	N = NP0	102 = 1000 pF	M = ±20%	V = Ni Barrier with 100% Tin Plating (Matte)	4 = Unmarked (Not available)	E = Embossed 7"
100 = 10V	X14 = 0603	W = X7R	104 = 0.10 µF	D* = ±0.50 pF	F = Polytherm Flexible Termination		T = Punched 7"
160 = 16V	X15 = 0805	X = X5R	5R6 = 5.6 pF	*Values < 10pF only	T = SnPb		No code = bulk
250 = 25V	X18 = 1206						Tape specs per EIA RS481
500 = 50V	X41 = 1210		1st two digits are significant; third digit denotes number of zeros				
101 = 100V	X44 = 1410						
500 = 500V	X43 = 1812						

# Planar Filter Capacitors for Transducer/Sensor Applications

## Superior Signal to Noise Ratio When Compared to SMT Filters

Planar Filter Capacitors are multilayer ceramic capacitors available in NPO or X7R dielectrics.

Military, industrial, and automotive transducers and sensors are sensitive to conducted and radiated EMI noise. In industrial applications, wiring that is routed over long distances acts as an antenna for noise, which further complicates performance. In vehicle systems, ignition noise and electric motor/actuator interference affect measurements. Planar filter capacitors are often used to ensure signal integrity and optimum performance. Johanson planar filters are designed to match the pin-out of the device's connector to provide the most efficient filtering at the transducer. The through hole filter capacitor design provides the lowest in ESR and ESL, yielding superior signal-to-noise ratio compared to discrete filter capacitors. Halting interference at the source is ALWAYS a preferred solution!

### Features

- Low ESL / Low ESR
- Geometry and layout custom to pin out of sensor
- Capacitance Range 100 PF to 0.5 $\mu$ F
- Voltage Ratings from 50V to 1KV. Higher voltages may be available subject to geometry considerations
- Ni/Au terminations for superior solderability and long shelf life
- Pin counts from 1 to 155 possible

### Benefits

- Superior filtering compared to SMT designs thanks to the "through-hole" filter design
- Custom geometries of these planar filters make assembly easier as the geometry matches the pin out of the sensors
- Planar substrates are very robust and suitable for harsh environments

### Ordering Information

Planar filters are all custom designs as are the part numbers. Planars can be built to customer specifications or can be custom designed to fit customer sensor. For custom designs, we require the following information at minimum:

- Capacitance value and tolerance
- Rated voltage and DWV requirement
- Length and width or OD (if circular)
- ID dimension or pin/contact size of sensor
- Thickness max



## Applications

These planar filters are a great fit for pressure sensors and transducers for multiple end markets.

Markets	End Product Applications
<b>Industrial</b>	Chemical, Petroleum, Food, Pharmaceutical, Construction, Agricultural, Heavy Equipment, Machine Tools, Advanced Automotive and Racing
<b>MIL-Aero</b>	Commercial, Military Avionics, Space, Military Hardware & Ordnance
<b>Medical</b>	Instrumentation, Pumps, Surgical and Diagnostic Equipment
<b>Test</b>	Instrumentation, Load Cells, etc.

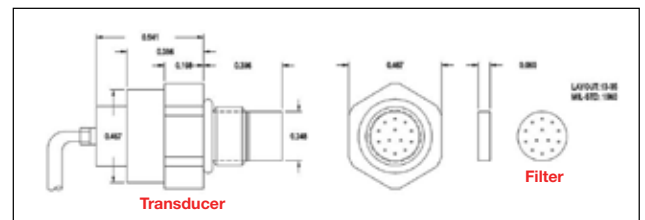

A typical sensor or transducer application of a planar filter cap

# Through Hole EMI Filters

## Superior Signal Noise Ratio Compared to Discretes

Through Hole EMI Filter is a multilayer ceramic filter available in NP0 or X7R Dielectrics.

Johanson Planar Arrays and Discoidal Caps Through Hole EMI filters are ideal EMI filter caps for use in filtered connectors, discrete EMI filters, sensors and transducers. These Through Hole EMI filters are custom designed to match the pin-out and shell dimensions of the device as specified by the customer.

The Through Hole EMI filter design and circumferential grounding scheme of these capacitors provide superior filtering performance compared to discrete capacitors/inductors. The robust nature of the Through Hole EMI filter is superior to tubular caps which may crack or break during handling and assembly.

Nickel/Gold plated terminals offer long shelf life and superior wetting and leach resistance compared to thick film silver metallization. Planars are available in all circular, D-Sub, ARINC

## Features

- Very low ESR/ESL resulting from Through Hole Filter Design
- Rated Voltages to 2KV (planars) and 3KV (discoidals)
- Pin-outs conform to all standard connector layouts or custom configurations for connectors, sensors, or transducers
- Cap values from 10pF through  $\mu$ F range, depending on layout
- Gold terminals for enhanced shelf life and improved solderability
- Available in high temp. dielectrics for use in conditions up to 200°C
- Conformal coating available to prevent arcing at higher voltages

## Benefits

- Improvement in Signal to Noise ratio
- Circumferential grounding provides infinite paths to ground, ensuring optimal filtering performance of the filter.
- Robust substrate construction guards against mechanical damage from thermal or mechanical stresses. For sensors, planars stop interference at the source
- Superior filtering performance over discrete solutions and are more robust than tubular capacitors.

## Ordering Information

Planar and discoidal parts are designed to specific customer requirements and thus have custom part numbers. Send your specification to receive a quotation and part number.

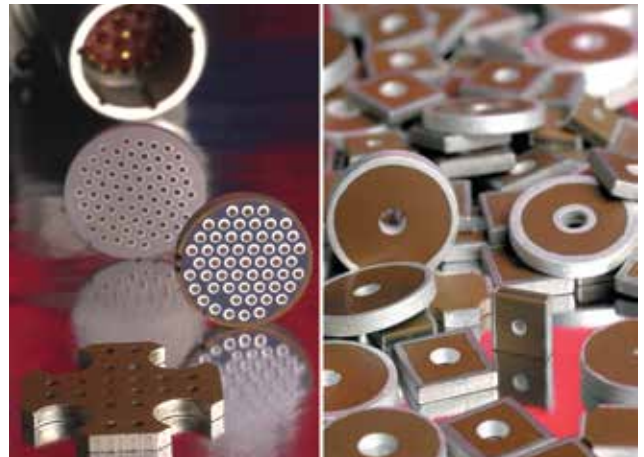

## Applications

Markets	End Product Applications
High end industrial	Filtered Connector
Audio MIL	Filtered Connector
Industrial	Transducers and Sensors
MIL-Aero	Filtered Connector Transducers and Sensors EMI can Filter & Feedthrough Filtered Chassis Feedthrough

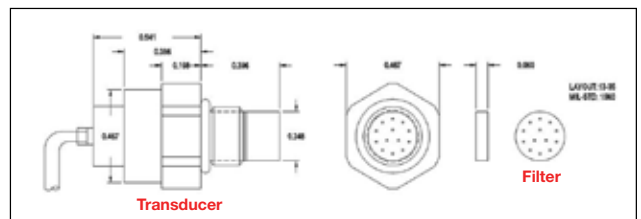

A typical sensor or transducer application of a planar filter cap

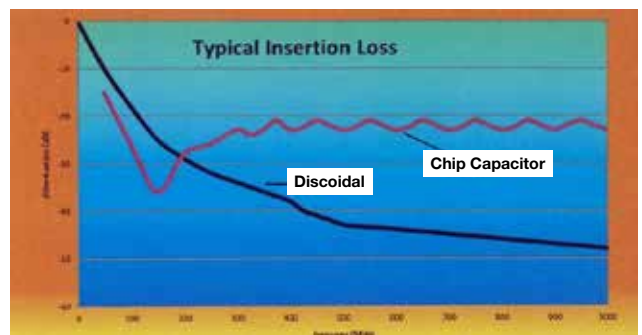

# Precision and Power Resistors

High Power and Ultra-High Precision to 0.01%

## RWP Series

**Precision Wirewound Resistors with Axial or Radial Lead**

Ultra tight tolerance (to 0.005%), Low TCR to  $\pm 2$ ppm/ $^{\circ}$ C



- Long Term Stability: 100ppm/year
- Temperature Range  $-55^{\circ}$ C to  $+145^{\circ}$ C
- Matched Resistance Sets to  $\pm 0.001$  and  $0.5$ ppm/ $^{\circ}$ C
- Options for Wide TCR Range, High Stability & Fast Rise Time
- Non-Inductive
- Power Range (W): 0.06 to 2.00 Watts
- Resistance Range ( $\Omega$ ): Up to 6M Ohms
- Tolerance Range:  $\pm 0.005\%$  to  $\pm 1\%$
- TCR:  $\pm 10, \pm 20, \pm 30$  ppm/ $^{\circ}$ C, custom available
- Tin Lead available (non-RoHS)

## RWH Series

**High Power Rating Wirewound Resistors with Axial Leads**

Excellent Pulse Handling, Low TCR to  $\pm 20$ ppm/ $^{\circ}$ C Standard



- MIL-R-26 / MIL-R-39007 Power Ratings
- Non-Inductive Windings available
- Temperature Range up to  $+350^{\circ}$ C
- Power Range (W): 0.1 to 15 Watts
- Resistance Range ( $\Omega$ ): 0.02 to 260K Ohms
- Tolerance Range:  $\pm 0.01\%$  to  $\pm 10\%$
- TCR:  $\pm 20, \pm 50$  ppm/ $^{\circ}$ C, custom available
- Tin Lead available (non-RoHS)

## RWF Series

**Surface Mount Precision Wirewound Resistors**

Ultra Tight Tolerance (to  $\pm 0.01$ ), Low TCR to  $\pm 20$  ppm/ $^{\circ}$ C



- Flame Resistance UL 94V-0
- High Temperature Rating up to  $275^{\circ}$ C
- Superior Surge Handling Capability
- Non-Inductive Windings available
- Insulation Resistance  $>1000$  MOhms/Dry
- Power Range (W): 0.5 to 4 Watts
- Resistance Range ( $\Omega$ ): 0.005 to 50k Ohms
- Tolerance Range:  $\pm 0.01\%$  to  $\pm 5\%$
- TCR:  $\pm 20, \pm 50, \pm 200$  ppm/ $^{\circ}$ C, custom available
- Tin Lead available (non-RoHS)

## RWC Series

**High Power Wirewound Mounted in Aluminum Housing**

Ultra Tight Tolerance (to  $\pm 0.01\%$ ), Low TCR to  $\pm 20$ ppm/ $^{\circ}$ C



- Excellent Pulse Handling
- High Temperature  $-55^{\circ}$ C +  $275^{\circ}$ C
- Non-Inductive Windings available
- Four Terminal Versions available (Call Factory)
- Power Range (W): 5 to 300 Watts
- Resistance Range ( $\Omega$ ): 0.005 to 250k Ohms
- Tolerance Range:  $\pm 0.01\%$  to  $\pm 10\%$
- TCR:  $\pm 20, \pm 50$  ppm/ $^{\circ}$ C, custom available
- Tin Lead available (non-RoHS)

## RHX Series

**High Power Low Inductance Resistor**

High Power Chassis Mount @ Low Cost, Low Inductance



- High Stability Film Resistance Elements
- TO-220 and TO-247 Housing
- Low Inductance:  
<10nH for RHXH1 and RHXH2 series  
<50nH for RHXH3 series
- Power Range (W): 35, 50, 100 Watts
- Resistance Range ( $\Omega$ ): 0.02 to 51K Ohms
- Tolerance Range:  $\pm 1\%$  to  $\pm 5\%$
- TCR:  $\pm 50, \pm 100, \pm 250$  ppm/ $^{\circ}$ C
- Tin Lead available (non-RoHS)

## RKS Series

**High Temperature Thick Film Resistors**

Special High Temperature version to  $300^{\circ}$ C, Non-Magnetic



- High Value Thick Film Resistance Element
- Temperature Range  $-55^{\circ}$ C to  $155^{\circ}$ C (standard version)
- Temperature Range  $-55^{\circ}$ C to  $300^{\circ}$ C (high temp version)  
TCR valid  $+25^{\circ}$ C to  $+125^{\circ}$ C
- Power Range (W): 0.05 to 2 Watts
- Resistance Range ( $\Omega$ ): 10M to 1T Ohms
- Tolerance Range:  $\pm 0.25\%$  to  $\pm 30\%$
- TCR:  $\pm 25, \pm 50, \pm 100, \pm 250, \pm 500, \pm 1000, \pm 2000, \pm 3000$  ppm/ $^{\circ}$ C
- Sizes: 0402, 0603, 0805, 1206, 2010, 2512, 4020



## RNP Series

### High Precision Thin Film Resistors

Tolerances to  $\pm 0.01\%$ , Low TCR to  $\pm 5\text{ppm}/^\circ\text{C}$

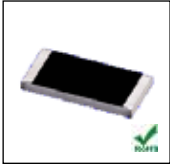

- High Power Rating available
- Operating Temperature  $-55^\circ\text{C}$  to  $155^\circ\text{C}$
- Max Working Voltage from 25V to 200V
- Max Overload Voltage from 50V to 400V
- Power Range (W): 0.06 to 0.75 Watts
- Resistance Range ( $\Omega$ ): 1 to 3M Ohms
- Tolerance Range:  $\pm 0.01\%$  to  $\pm 1.0\%$
- TCR:  $\pm 5$ ,  $\pm 10$ ,  $\pm 15$ ,  $\pm 25$ ,  $\pm 50\text{ppm}/^\circ\text{C}$
- Sizes: 0402, 0603, 0805, 1206, 2010, 2512

## RMC Series

### Current Sense Metal Element Resistors

Low Inductance, Very Low Resistances, Reliable at Higher Currents (up to 40A)



- For Current Sensing and Shunt Applications
- Low inductance  $<10\text{nH}$
- All Welded Construction
- Economical Bare Metal Element
- Power Range (W): 1 to 5 Watts
- Resistance Range ( $\Omega$ ): 0.005 to 0.100
- Tolerance Range:  $\pm 1\%$ ,  $\pm 5\%$
- TCR:  $\pm 20\text{ppm}/^\circ\text{C}$
- Tin Lead available (non-RoHS)

## RNC Series

### Thin Film Current Sense Resistors

Power Rating Up to 3 Watts (small SMT part)



- Customized Resistance available
- Temperature Range  $-55^\circ\text{C}$  to  $170^\circ\text{C}$
- Power Range (W): 1 to 3 Watts
- Resistance Range ( $\Omega$ ): 0.5 to 15 mOhm
- Tolerance Range:  $\pm 1.0\%$  to  $\pm 5.0\%$
- TCR:  $\pm 50$ ,  $\pm 75$ ,  $\pm 100$ ,  $\pm 150$ ,  $\pm 200\text{ppm}/^\circ\text{C}$
- Sizes: 1206, 2010, 2512

## RHF Series

### Power Thin Film Resistors

Compact TO-263 Housing, Low TCR to  $\pm 50\text{ppm}/^\circ\text{C}$

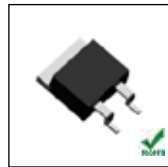

- Low Stability to 1%
- Isolated Back Plate
- Solder Reflow Secure at  $260^\circ\text{C}/20\text{s}$
- Temperature Range  $-55^\circ\text{C}$  to  $155^\circ\text{C}$
- Power Range (W): 35 Watts
- Resistance Range ( $\Omega$ ): 0.01 to 51K Ohm
- Tolerance Range:  $\pm 1\%$  to  $\pm 5\%$
- TCR:  $\pm 50\text{ppm}/^\circ\text{C}$

# S-Series High Frequency Capacitors

## Ultra High-Q Low ESR NPO/COG Multilayer Ceramic Capacitors

Johanson S-series are High-Q MLCC, ultra-low loss ceramic capacitors for high frequency applications.

These low ESR capacitors are available in standard EIA sizes (0402, 0603, and 0805 package), and are typically used in consumer, infrastructure and industrial markets.

In addition to their excellent performance, reliability and consistency in volume production has been the focus.

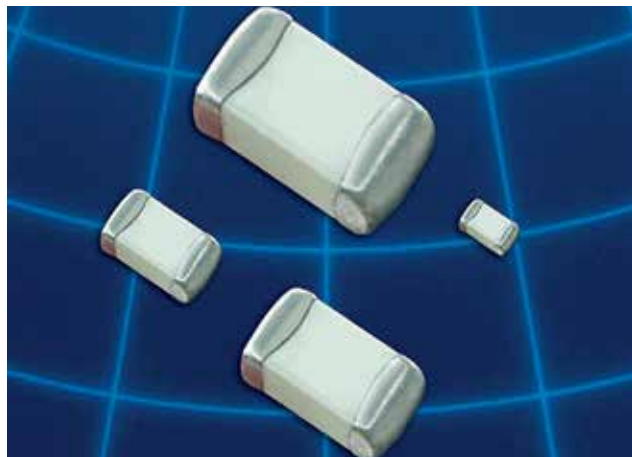

### Features

- Lowest ESR in class
- Best (NPO/COG) Temperature Stability
- Sizes: 0402, 0603, 0805
- Capacitance Range 0.2 pF to 220 pF
- Highest Voltage Ratings in class
- High Self-Resonant Frequency
- 100% screening to guarantee defect free capacitors
- Non-Porous Ceramic Material (also called Porcelain)
- Vertical Orientation available for all sizes
- Numerous Termination Options
- ROHS Compliant
- Controlled layer count

### Benefits

- Consistent performance lot to lot, month to month
- Higher PA Efficiency
- Longer Battery Life
- Improved Receiver Sensitivity
- Less Heating from Capacitors
- More consistent filter performance

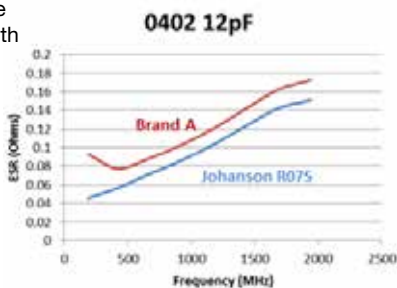

### Applications

The reliability and consistency of Johanson S-series High-Q, low ESR capacitors have made them the clear choice for medium and lower power RF applications.

Markets	End Product Applications
Cellular Base Stations	RF Power Amplifiers
Point to Point Radio-Link	RF Power Amplifiers
Energy Management	Wireless Meters
Military Communications	RF Modules
Radio & TV Broadcast	RF Power Amplifier
Medical MRI	Receive Coils
Private Mobile Radios	RF Power Amplifiers
RF Modules	Band-Pass Filters
Oscillators	Voltage Controlled Oscillator
Industrial Lasers	RF Generators

### Ordering Information

Example P/N: 251R14S101JV4T

Voltage	Size	Dielectric	Cap	Tolerance	Termination	Marking	Packaging
251 250V	R14S 0603	S High-Q	101 100 pF	J 5%	V NiSn	4 Unmarked	T Tape and Reel

# E-Series High RF Power Capacitors

## High-Q/Lowest ESR Available!

Johanson Silver E-Series Capacitors are High RF power and low loss ceramic multilayer RF capacitors (High Frequency MLCC's).

This ultra-High-Q E-Series of products use nearly pure silver electrodes, which is a superior high frequency conductor compared to palladium. Accordingly, the performance of these products sets a new standard in the industry for low ESR capacitors.

Utilizing a modern dielectric system, these NP0 capacitors exhibit the lowest losses, excellent high voltage performance and excellent temperature stability.

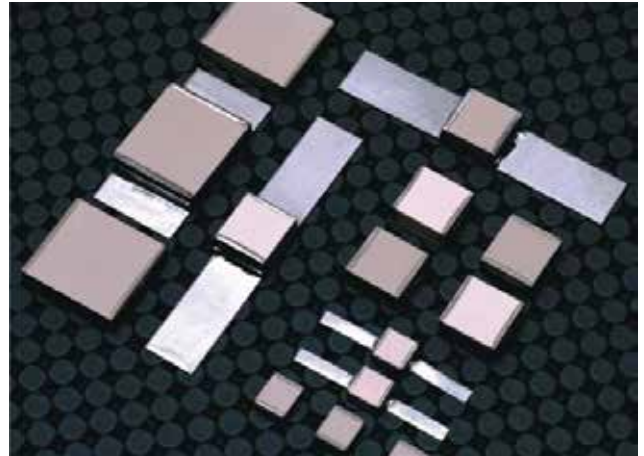

## Features

- Low ESR (High-Q) Design
- Ultra-Stable NPO Performance
- Sizes: 1111, 2525 and 3838
- Capacitance Range 1 pF to 5100 pF
- High Voltage Rating up to 7200V
- High RF Current/Power
- High Reliability
- Numerous Termination and Lead Options
- Custom Assemblies
- Low Loss Coating (RF Encapsulation) Available
- Controlled Layer Counts

## Benefits

- Superior Conductivity (lower ESR)
- Less Circuit Heating
- Lower Losses
- Higher PA Efficiency
- Improved Receiver Sensitivity
- Lower Cost

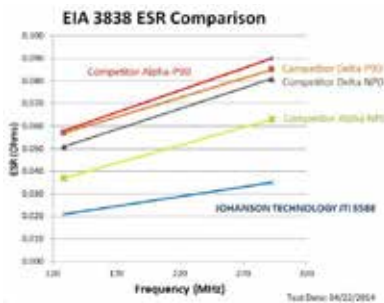

## Applications

These products are a great fit for all high power / high voltage RF circuits.

Markets	End Product Applications
Medical MRI	MRI Coil & Amplifiers
Medical NMR	NMR Spectroscopy
Broadcast Systems	VHF/UHF RF Power Amplifier
Cellular Base Stations	Communication Amplifiers
Semiconductor Equipment	RF Plasma Generators
Industrial Lasers	Laser Generators
Industrial RF Heaters	Chemical Analysis
Lightning Protection	CATV Set Top Box
Military and Industrial	Matching Boxes
Military Systems	Signal Jamming
Consumer Electronic	Wireless Charging

## Ordering Information

Example P/N: [152S48E471JU3E](#)

Voltage	Size	Dielectric	Cap	Tolerance	Termination	Marking	Packaging
152 1500V	S48 2525	E High-Q	471 470 pF	J 5%	U CuSn	3 Marked	E Tape and Reel

# Miniature Ceramic Chip Antennas

## Support for Antenna Design, Layout, Tuning, and Validation Process

The chip antennas are made using Low Temperature Cofired Ceramic (LTCC) Technology which has the ability to embed low and high dielectric constants inside our antenna. This enables them to have great detuning resilience and extreme temperature stability (~2ppm) behavior.

Our ceramic chip antennas offer SMD manufacturability in standard or small form-factor designs/applications (i.e. miniature bluetooth, zigbee, ISM, WLAN antennas) provide great reliability and versatility while maintaining industry demanding performance. These chip antennas are easy to tune to any unique PCB environment. For qualified opportunities, we offer 2 free complimentary RF layout design reviews if you choose to use one of our components!

### Features

- Lowest ESR in class
- Best (NPO/COG) Temperature Stability
- Sizes: 0402, 0603, 0805
- Capacitance Range 0.2 pF to 220 pF
- Highest Voltage Ratings in class
- High Self-Resonant Frequency
- 100% screening to guarantee defect free capacitors
- Non-Porous Ceramic Material (also called Porcelain)
- Vertical Orientation available for all sizes
- Numerous Termination Options
- ROHS Compliant
- Controlled layer count

### Benefits

- Better detuning resilience than PCB and whip antennas
- Guaranteed resonance in mass production
- Comes with antenna design assistance of 2 complimentary layout optimization reviews and also (lab fee may apply) antenna tuning, validation, and characterization service.
- Our lab service includes an RF antenna design engineer validating your prototype, complete RF tuning (with p/ ns provided), anechoic chamber OTA (Over the Air) gain, efficiency, and radiation plots, and any last design optimization observations.



### Applications

Markets	End Product Applications
<b>BLE/Bluetooth</b>	Small Form Factor Wearable Devices Portable Audio Sensors (coin-cell size) Tags, Tracers, iBeacon Automotive Enter/Infotainment
<b>Monitoring and Control Systems (M2M)</b>	RF Thermal Sensors Advanced Thermostats Home Automation /RF Locks POS/Payments Systems Automated Meter Readers
<b>WiFi/802.11</b>	In-vehicle WiFi Hotspot WiFi Access Points Chipset-Specific FEMs
<b>GPS/GLNSS</b>	Portable Positioning Modules Vehicle/Insurance Tracking Battery Powered Small Form Factor
<b>Cellular</b>	Handset Portable Hotspot

One of the smallest form-factor RF antenna solutions available backed by the best RF technical design assistance.

