

6W, wide input, isolated & regulated dual/  
single output, DIP package, DC-DC converter

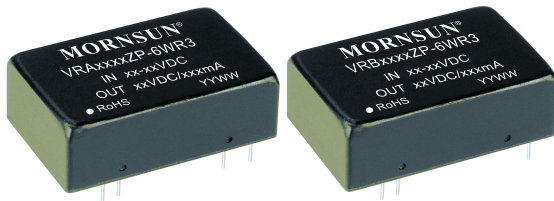

Patent Protection RoHS

### FEATURES

- Wide input voltage range (2:1)
- High efficiency up to 88%
- No-load power consumption as low as 0.09W
- Isolation voltage : 1500VDC
- Operating temperature range: -40°C to +85°C
- Input under-voltage protection, output short circuit, over-current, over-voltage protection
- Meet CISPR22/EN55022 CLASS A without external components
- International standard pin-out

VRA\_ZP-6WR3 & VRB\_ZP-6WR3 series products are of 6W output power, wide range of voltage input of 9-18VDC, 18-36VDC, 36-75VDC isolation voltage of 1500VDC, input under-voltage protection, output over-voltage, over-current, short circuit protection and EMI meets CISPR22/EN55022 CLASS A without external components; these products are widely used in fields such as industrial control, electric power, instruments and communication.

### Selection Guide

Certification	Part No.	Input Voltage (VDC)		Output		Efficiency <sup>②</sup> (%M in./Typ.) @ Full Load	Max. Capacitive Load <sup>③</sup> (μF)
		Nominal (Range)	Max. <sup>①</sup>	Output Voltage (VDC)	Output Current (mA) (Max./Min.)		
-	VRA1205ZP-6WR3	12 (9-18)	20	±5	±600/0	78/80	680
	VRA1212ZP-6WR3			±12	±250/0	82/84	330
	VRA1215ZP-6WR3			±15	±200/0	83/85	220
	VRA1224ZP-6WR3			±24	±125/0	82/84	100
	VRB1203ZP-6WR3			3.3	1500/0	73/75	1800
	VRB1205ZP-6WR3			5	1200/0	78/80	1000
	VRB1212ZP-6WR3			12	500/0	82/84	470
	VRB1215ZP-6WR3			15	400/0	83/85	220
	VRB1224ZP-6WR3			24	250/0	83/85	100
	VRA2405ZP-6WR3			24 (18-36)	40	±5	±600/0
	VRA2412ZP-6WR3	±12	±250/0			84/86	330
	VRA2415ZP-6WR3	±15	±200/0			85/87	220
	VRA2424ZP-6WR3	±24	±125/0			83/85	100
	VRB2403ZP-6WR3	3.3	1500/0			76/78	1800
	VRB2405ZP-6WR3	5	1200/0			80/82	1000
	VRB2412ZP-6WR3	12	500/0			83/85	470
	VRB2415ZP-6WR3	15	400/0			84/86	220
	VRB2424ZP-6WR3	24	250/0			84/86	100
	VRA4805ZP-6WR3	48 (36-75)	80			±5	±600/0
	VRA4812ZP-6WR3			±12	±250/0	85/87	330
	VRA4815ZP-6WR3			±15	±200/0	83/85	220
	VRA4824ZP-6WR3			±24	±125/0	83/85	100
	VRB4803ZP-6WR3			3.3	1500/0	77/79	1800
	VRB4805ZP-6WR3			5	1200/0	81/83	1000
VRB4812ZP-6WR3	12			500/0	85/87	470	
VRB4815ZP-6WR3	15			400/0	86/88	220	
VRB4824ZP-6WR3	24			250/0	85/87	100	

Notes:

- ① Absolute maximum rating without damage on the converter, but it isn't recommended;
- ② Efficiency is measured in nominal input voltage and rated output load;
- ③ The capacitive loads of positive and negative outputs are identical.

### Input Specifications

Item	Operating Conditions	Min.	Typ.	Max.	Unit
Input Current (full load / no-load)	12VDC input	--	625/7	642/25	mA
	24VDC input	--	305/7	313/25	
	48VDC input	--	151/7	155/25	
Reflected Ripple Current		--	20	--	
Input impulse Voltage (1sec. max.)	12VDC input	-0.7	--	25	VDC
	24VDC input	-0.7	--	50	
	48VDC input	-0.7	--	100	
Starting Voltage	12VDC input	--	--	9	VDC
	24VDC input	--	--	18	
	48VDC input	--	--	36	
Under-voltage turn-off	12VDC input	5.5	6.5	--	
	24VDC input	13	15	--	
	48VDC input	26	30	--	
Input Filter		Pi filter			
Hot Plug		Unavailable			

### Output Specifications

Item	Operating Conditions	Min.	Typ.	Max.	Unit
Output Voltage Accuracy <sup>①</sup>	Positive output	--	±1	±3	
	Negative output				
Line Regulation	Full load, the input voltage is from low voltage to high voltage	Positive output	±0.2	±0.5	%
		Negative output	±0.5	±1	
Load Regulation <sup>②</sup>	5%-100% load	Positive output	±0.5	±1	%
		Negative output	±0.5	±1.5	
Cross Regulation	Dual output, main circuit with 50% load, auxiliary circuit with 10%-100% load	--	--	±5	
Transient Recovery Time		--	300	500	μs
Transient Response Deviation	25% load step change	3.3V, 5V, ±5V output	±5	±8	%
		Others	±3	±5	
Temperature Coefficient	Full load	--	--	±0.03	%/°C
Ripple&Noise <sup>③</sup>	20MHz bandwidth, 5%-100% load	--	--	100	mV p-p
Over-voltage Protection	Input voltage range	110	--	160	%Vo
Over-current Protection		110	140	190	%Io
Short circuit Protection		Continuous, self-recovery			

Note: ① At 0%~5% load, the Max. output voltage accuracy of ±5VDC output converter is ±5%.

② When testing from 0% to 100% load working conditions, load regulation index of ±5%;

③ 0%-5% load ripple&Noise is no more than 5%Vo. Ripple and noise are measured by "parallel cable" method, please see DC-DC Converter Application Notes for specific operation.

### General Specifications

Item	Operating Conditions	Min.	Typ.	Max.	Unit
Isolation Voltage	Input-output, with the test time of 1 minute and the leak current lower than 1mA	1500	--	--	VDC
Insulation Resistance	Input-output, insulation voltage 500VDC	1000	--	--	MΩ
Isolation Capacitance	Input-output, 100KHz/0.1V	--	1000	--	pF
Operating Temperature	Derating if the temperature is ≥71°C (see Fig. 1)	-40	--	85	°C
Storage Temperature		-55	--	125	
Storage Humidity	Non-condensing	5	--	95	%RH
Pin Welding Resistance Temperature	Welding spot is 1.5mm away from the casing, 10 seconds	--	--	300	°C

Vibration		10-55Hz, 10G, 30 Min. along X, Y and Z			
Switching Frequency *	PWM mode	--	300	--	KHz
MTBF	MIL-HDBK-217F@25°C	1000	--	--	K hours

Note: \* This series of products using reduced frequency technology, the switching frequency is test value of full load, When the load is reduced to below 50%, the switching frequency decreases with decreasing load.

**Physical Specifications**

Casing Material	Aluminum alloy
Package Dimensions	32.00*20.00*10.80mm
Weight	14g(Typ.)
Cooling Method	Free air convection

**EMC Specifications**

EMI	CE	CISPR22/EN55022 CLASS A (Bare component)/ CLASS B (see Fig.3-② for recommended circuit)	
	RE	CISPR22/EN55022 CLASS A (Bare component)/ CLASS B (see Fig.3-② for recommended circuit)	
EMS	ESD	IEC/EN61000-4-2	Contact ±4KV perf. Criteria B
	RS	IEC/EN61000-4-3	10V/m perf. Criteria A
	EFT	IEC/EN61000-4-4	±2KV (see Fig.3-① for recommended circuit) perf. Criteria B
	Surge	IEC/EN61000-4-5	±2KV (see Fig.3-① for recommended circuit) perf. Criteria B
	CS	IEC/EN61000-4-6	3 Vr.m.s perf. Criteria A
	Immunities of voltage dip, drop and short interruption	IEC/EN61000-4-29	0-70% perf. Criteria B

**Product Characteristic Curve**

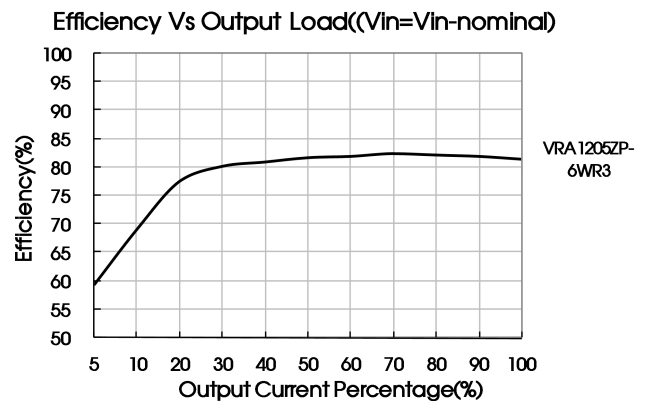
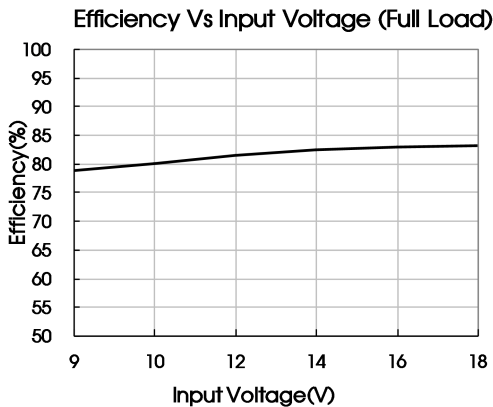
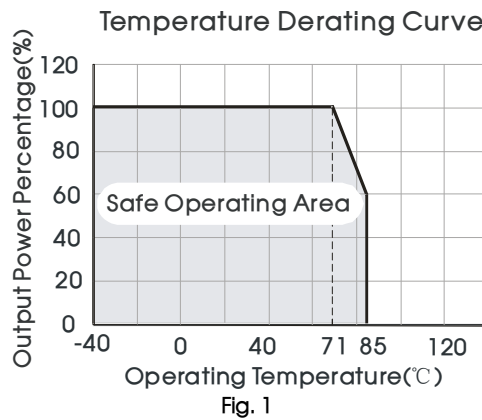

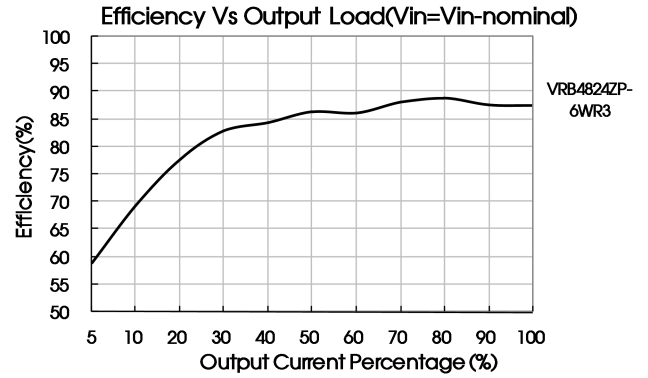
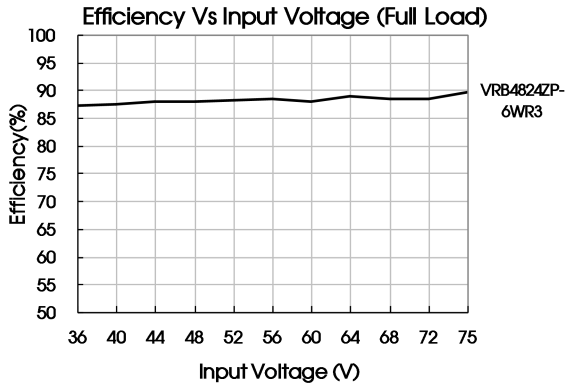

Design Reference

1. Typical application

All the DC/DC converters of this series are tested according to the recommended circuit (see Fig. 2) before delivery. If it is required to further reduce input and output ripple, properly increase the input & output of additional capacitors  $C_{in}$  and  $C_{out}$  or select capacitors of low equivalent impedance provided that the capacitance is no larger than the max. capacitive load of the product.

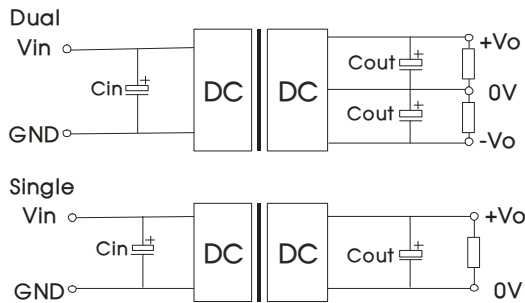

Fig. 2

Vin(VDC)	Cin	Cout
12/24	100 $\mu$ F	10 $\mu$ F
48	10 $\mu$ F ~47 $\mu$ F	10 $\mu$ F

2. EMC solution-recommended circuit

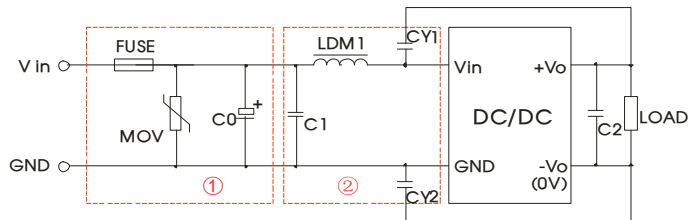

Fig. 3

Notes: Part ① in the Fig. 3 is used for EMS test and part ② for EMI filtering; selected based on needs.

Parameter description:

Model	Vin:12V	Vin:24V	Vin:48V
FUSE	Choose according to actual input current		
MOV	S14K20	S20K30	S14K60
C0	1000 $\mu$ F/35V	1000 $\mu$ F/50V	680 $\mu$ F/100V
C1	1 $\mu$ F/50V		1 $\mu$ F/100V
C2	Refer to the Cout in Fig.2		
LDM1	4.7 $\mu$ H		
CY1, CY2	1nF/2KV		

3. The product does not support output in parallel with power per liter

4. For more information please find the application notes on [www.mornsun-power.com](http://www.mornsun-power.com)

Dimensions and Recommended Layout

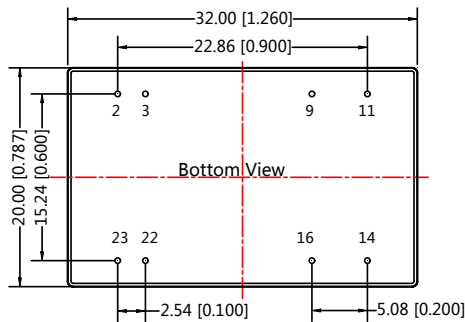
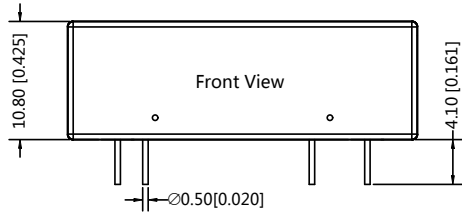

Note:  
Unit :mm[inch]  
Pin diameter tolerances :±0.10[±0.004]  
General tolerances:±0.50[±0.020]

THIRD ANGLE PROJECTION

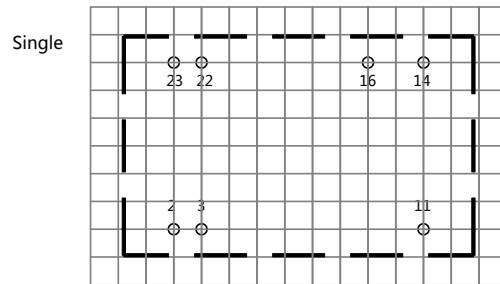
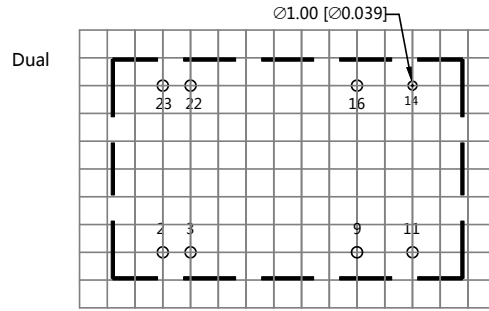

Note:Grid 2.54\*2.54mm

Pin	Single	Dual
2,3	GND	GND
9	No Pin	0V
11	NC	-Vo
14	+Vo	+Vo
16	0V	0V
22,23	Vin	Vin

NC: No Connection

Notes:

1. Packing Information please refer to 'Product Packing Information'. Packing bag number : 58210008;
2. The unbalance degree of the recommended dual output module load: ≤ 5%; if the degree exceeds ±5%, then the product performances cannot be guaranteed to comply with all the performance indicators in the manual, and please directly contact our technicians for specific information;
3. The max. capacitive load should be tested within the input voltage range and under full load conditions;
4. Unless otherwise specified, data in this datasheet should be tested under the conditions of Ta=25°C, humidity<75%RH when inputting nominal voltage and outputting rated load;
5. All index testing methods in this datasheet are based on our Company's corporate standards;
6. The performance indexes of the product models listed in this datasheet are as above, but some indexes of non-standard model products will exceed the above-mentioned requirements, and please directly contact our technicians for specific information;
7. We can provide product customization service;
8. Specifications of this product are subject to changes without prior notice.

Mornsun Guangzhou Science & Technology Co., Ltd.

Address: No. 5, Kehui St. 1, Kehui Development Center, Science Ave., Guangzhou Science City, Luogang District, Guangzhou, P. R. China  
Tel: 86-20-38601850-8801 Fax: 86-20-38601272 E-mail: [info@mornsun.cn](mailto:info@mornsun.cn)