

3W, Isolated CAN ACDC power supply **FEATURES**

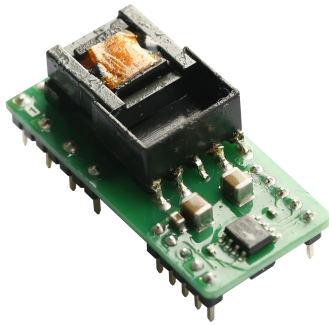

RoHS



- Wide input voltage range: 85-305VAC/100-430VDC
- AC & DC (same terminal input voltage)
- Isolation voltage: 4000VAC
- Output short circuit, over-current protection
- High baud rate up to 1Mkbps
- The bus is able to support 110 nodes at maximum
- Open frame, Compact size, High power density
- Flexible design of peripheral circuit reduces layout problems
- Meets UL60950、EN60950 standards

TLAxx-03KCAN series for the integration of CAN 3W AC DC power supply, the product can be directly connected to the mains AC220V power supply. The output power of the main channel DC power supply is 2.5W, the auxiliary DC power output is used for bus communication. The input AC power source and the two output DC power supply have high isolation voltage of 4000VAC, and the two outputs DC power supply isolation voltage between 1500VDC. Widely used in industrial and electrical instrumentation and other demanding on the volume, wide input voltage requirements, the use of isolation bus, the need to meet UL / CE certification and EMC requirements are not high occasions. This series of products used in electromagnetic compatibility more harsh environment must refer to the recommended circuit.

Selection Guide

Part No.	Output Power	Rated Output Voltage(V)	Rated Output Current I _o (mA)	Efficiency (230VAC, %/Typ.)	Baud rate (kbps)	Number of Nodes
TLA03-03KCAN	3W	3.3V(1.65W)/5V(0.125W)	500/25	55	5-1000	110
TLA05-03KCAN		5V(2.5W)/5V(0.125W))	500/25	68		

Power Input Specifications

Item	Operating Conditions	Min.	Typ.	Max.	Unit
Input Voltage Range	AC input	85	--	305	VAC
	DC input	100	--	430	VDC
Input Frequency		47	--	63	Hz
Input Current	115VAC	--	--	0.15	A
	277VAC	--	--	0.07	
Input Surge Voltage	115VAC	--	--	13	
	277VAC	--	--	23	
Recommended External Input Fuse	Rated current 1.0A, slow blow fuse, necessary				
Hot Plug	Unavailable				

Power Output Specifications

Item	Operating Conditions		Min.	Typ.	Max.	Unit	
Output Voltage Accuracy	Balanced load	Primary output	3.3V	3.0	3.3	3.6	VDC
			5V	4.75	5	5.25	
	Secondary output	5V	--	5	--		
Line Regulation	Balanced load	Primary output	--	--	±1.5	%	
		Secondary output	--	--	±2		
Load Regulation	Double isolated output (Primary output)		--	--	±5		
Ripple & Noise*	20MHz bandwidth (peak-peak value)	Primary output	--	--	200	mV	
		Secondary output	--	--	300		
Temperature Coefficient			--	--	±0.15	%/°C	
Short Circuit Protection			Continuous, self-recovery				
Over-current Protection			120 - 300%I _o , self-recovery				
Min. Load	Double isolated output (Primary output)		50	--	--	mA	
	Double isolated output (Secondary output)		10	--	--		
Max. Capacitive Load (μF)			1500(Primary output)/22(Secondary output)				μF

Note: * Ripple and noise are measured by "parallel cable" method, please see AC-DC Converter Application Notes for specific operation.

Signal Input Specifications(+Vo1=3.3V)

Item		Symbol	Min.	Typ.	Max.	Unit
TXD Logic Level	High-level	V _{IH}	0.7*(+Vo1)	--	+Vo1	VDC
	Low-level	V _{IL}	0	--	0.8	
RXD Logic Level	High-level	V _{OH}	(+Vo1) - 0.4	3.1	-	
	Low-level	V _{OL}	0	0.2	0.4	
TXD Drive Current		I _T	2	--	--	mA
RXD Output Current		I _R	--	--	2	
Serial Interface	Standard CAN controller interface for +3.3V					

Signal Input Specifications(+Vo1=5.0V)

Item		Symbol	Min.	Typ.	Max.	Unit
TXD Logic Level	High-level	V _{IH}	0.7*(+Vo1)	--	+Vo1	VDC
	Low-level	V _{IL}	0	--	0.8	
RXD Logic Level	High-level	V _{OH}	(+Vo1) - 0.4	4.8	-	
	Low-level	V _{OL}	0	0.2	0.4	
TXD Drive Current		I _T	2	--	--	mA
RXD Output Current		I _R	--	--	4	
Serial Interface	Standard CAN controller interface for both +3.3V and +5.0V.					

Signal Output Specifications

Item		Symbol	Min.	Typ.	Max.	Unit
Dominant Level (Logic 0)	CANH	V _{(OD)CANH}	2.75	3.5	4.5	VDC
	CANL	V _{(OD)CANL}	0.5	1.5	2.25	
Recessive Level (Logic 1)	CANH	V _{(OR)CANH}	2	2.5	3	
	CANL	V _{(OR)CANL}	2	2.5	3	
Difference Level	Dominant Level (Logic 0)	V _{diff(d)}	1.5	2	3	
	Recessive Level (Logic 1)	V _{diff(r)}	-0.12	0	0.05	
Bus Pin Maximum Withstand Voltage		V _X	-36	--	+36	
Bus transient voltage		V _{tr} , Meet ISO7637-3 standard	-150	--	+100	
Bus Pin Leakage Current		(V _{DD} =0V, V _{CANH/L} =5V)	-5	--	5	uA
Differential Load Resistance		R _L	45	60	65	Ω
CAN Bus Interface	Meet ISO/DIS 11898 standard Twisted-pair output					

Signal Transmission Specifications

Item		Symbol	Min.	Typ.	Max.	Unit
Data Delay	TXD Transmit Delay	t _T	--	55	115	ns
	RXD Receive Delay	t _R	--	65	135	
	Cycle Delay	t _{PRO(TXD-RXD)}	--	120	250	

General Specifications

Item		Symbol	Min.	Typ.	Max.	Unit	
Isolation voltage	Input-output	With the test time of 1 minute and the leak current lower than 5mA	AC-DC	4000	--	--	VAC
			DC-DC	1500	--	--	VDC
Operating Temperature			-40	--	+85	°C	
Storage Temperature			-40	--	+105		
Storage Humidity			--	--	85	%RH	
Power Derating	Operating temperature derating	-40°C to -20°C	3.0	--	--	% / °C	
		+70°C to +85°C	1.67	--	--		
	Input Voltage derating	85VAC-100VAC	1.2	--	--	% / VAC	
		277AVC-305VAC	1.1	--	--		
MTBF		MIL-HDBK-217F@25°C	>300,000 h				

Physical Specifications

Dimensions	41.8*19.62*12.24 mm
Weight	8g (Typ.)
Cooling Method	Free air convection

EMC Specifications

EMI	CE	CISPR32/EN55032	CLASS A (see Fig. 1)	
		CISPR32/EN55032	CLASS B (see Fig. 2)	
	RE	CISPR32/EN55032	CLASS A (see Fig. 1)	
		CISPR32/EN55032	CLASS B (see Fig. 2)	
EMS	ESD	IEC/EN 61000-4-2	Contact ±4KV (Power output port and bus port)	Perf. Criteria B
	EFT	IEC/EN61000-4-4	±2KV (see Fig. 1)	perf. Criteria B
		IEC/EN61000-4-4	±4KV (L, N) (see Fig. 2)	perf. Criteria B
	Surge	IEC/EN61000-4-5	±1KV (L, N) (see Fig. 1)	perf. Criteria B
		IEC/EN61000-4-5	±2KV (CANH, CANL)	perf. Criteria B

Product Characteristic Curve

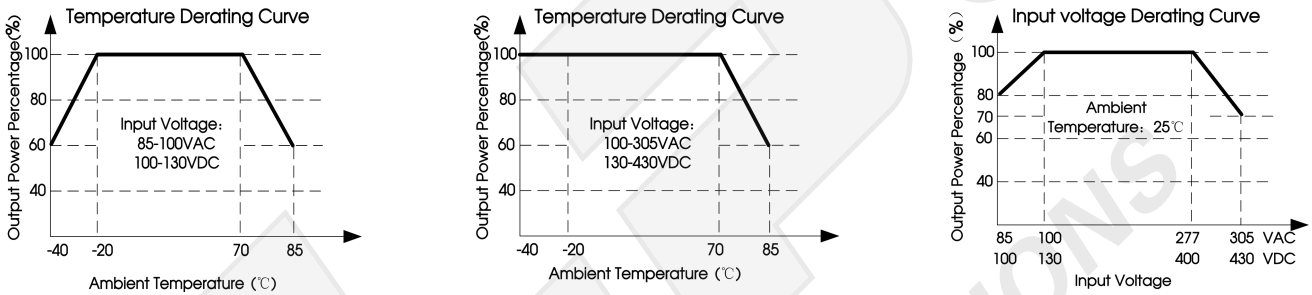

Note:

- The products should have input voltage derating based on temperature derating when it is 85 - 100VAC/277- 305VAC/100 - 130VDC/400 - 430VDC voltage input;
- This product is suitable for use in natural air cooling environments, if in a closed environment, please contact our company's FAE.

Design Reference

1. Typical application circuit

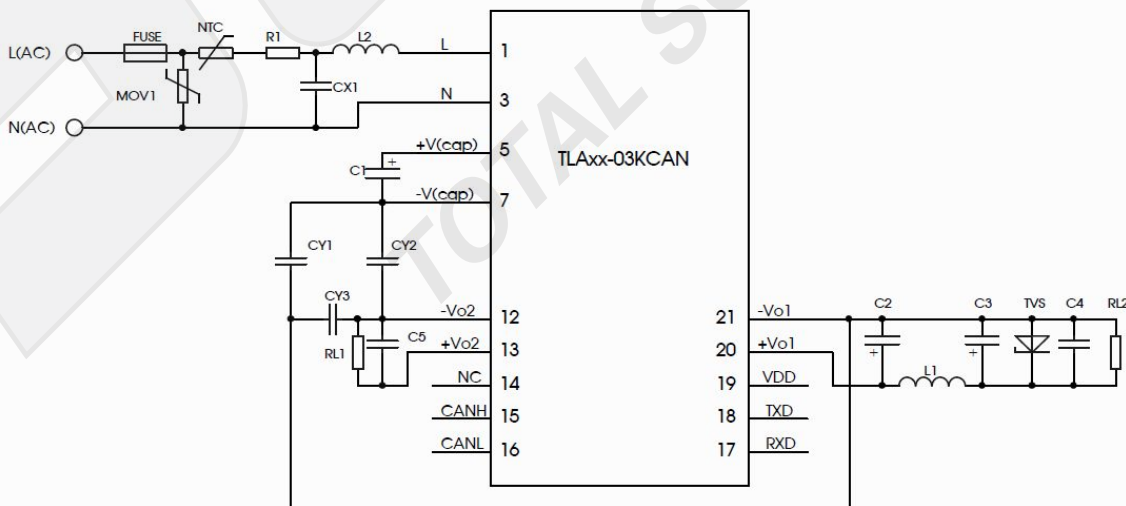

Fig.1

FUSE	C1	L2	NTC	C2	L1	C3	C4	CY1/CY2	TVS	CY3	CX1	C5
necessary				necessary				necessary		necessary		necessary
1A/300V	22uF/450V -40 to 85°C	4.7mH	13D-5	270uF/16V (Solid Capacitor)	4.7uH	120uF/ 25V	0.1uF	2200pF	SMBJ7.0A	560pF	0.047uF /480V	100uF/16V

2. EMC solution-recommended circuit

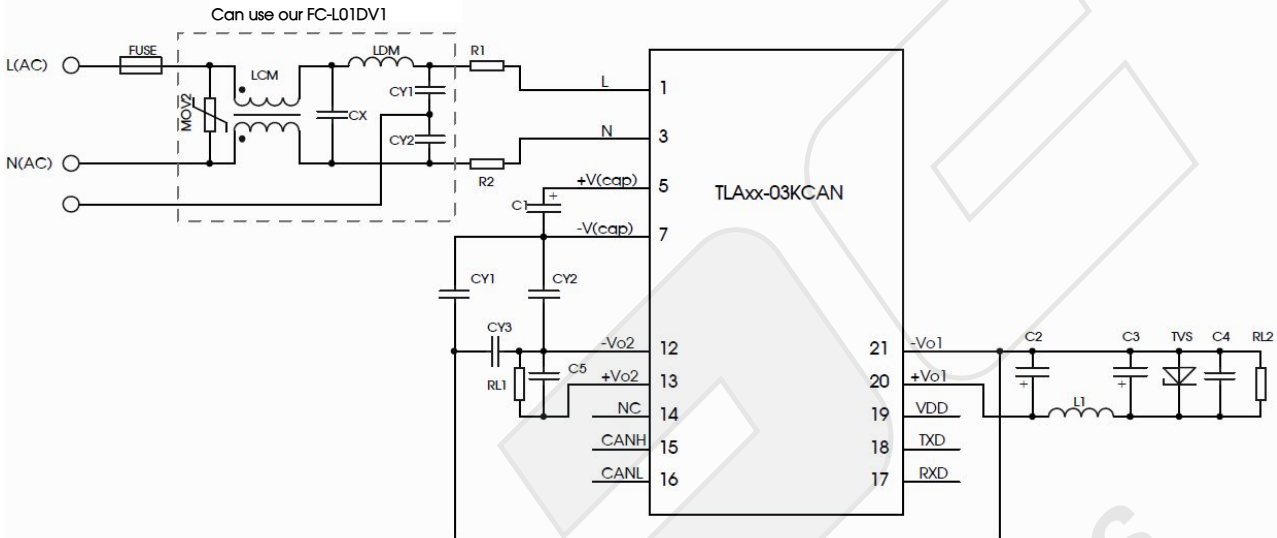
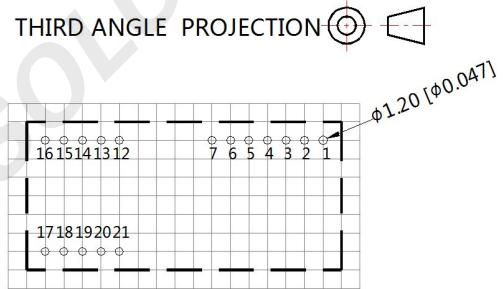
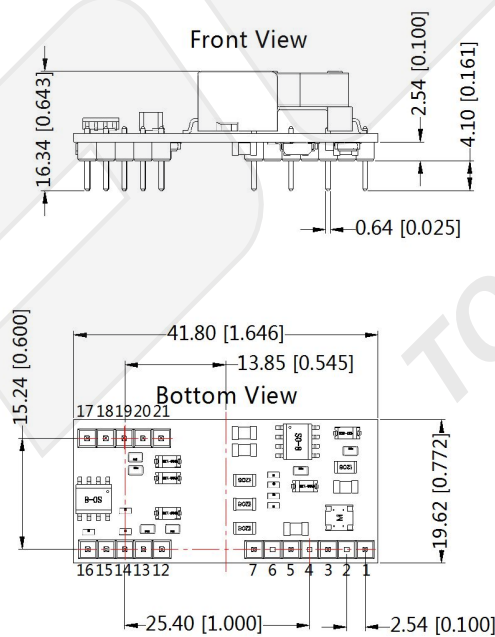

Fig.2

R1, R2: for the current limiting resistor, Recommended value 12Ω, 2W; MOV1 recommended 14D561.
When using the recommended circuit, you need to add 2kΩ dummy load.

3. For more information about Mornsun EMC Filter products, please visit www.mornsun-power.com to download the Selection Guide of EMC Filter

Dimensions and Recommended Layout



Note: Grid 2.54*2.54mm

Pin-In&Out			
Pin	Function	Pin	Function
1	AC(L)	12	-Vo2
2	-	13	+Vo2
3	AC(N)	14	NC
4	-	15	CANH
5	+V(cap)	16	CANL
6	-	17	RXD
7	-V(cap)	18	TXD
8	-	19	VDD
9	-	20	+Vo1
10	-	21	-Vo1
11	-	22	-

Note:
Unit: mm[inch]
Pin section tolerances: ±0.1[0.004]
General tolerances: ±1[±0.039]

1. Packing information please refer to Product Packing Information which can be downloaded from www.mornsun-power.com. Packing bag number:58220026;
2. This model is open plate, in order to meet the safety requirements of the module primary and secondary external components between the need to maintain a safe distance of at least 6.4mm;
3. Unless otherwise specified, parameters in this datasheet were measured under the conditions of $T_a=25^{\circ}\text{C}$, humidity<75% with nominal input voltage (115V and 230V)and rated output load;
4. In order to improve the efficiency of conversion at light load, the module may have audio noise, but does not affect product performance and reliability;
5. After the module is assembled, it needs to be fixed
6. All index testing methods in this datasheet are based on our Company's corporate standards;
7. We can provide product customization service;
8. Products are related to laws and regulations: see "Features" and "EMC".
9. Our products shall be classified according to ISO14001 and related environmental laws and regulations, and shall be handled by qualified units

Mornsun Guangzhou Science & Technology Co., Ltd.

Address: No. 5, Kehui St. 1, Kehui Development Center, Science Ave., Guangzhou Science City, Luogang District, Guangzhou, P. R. China
Tel: 86-20-38601850-8801