

# The One and a Half Bag

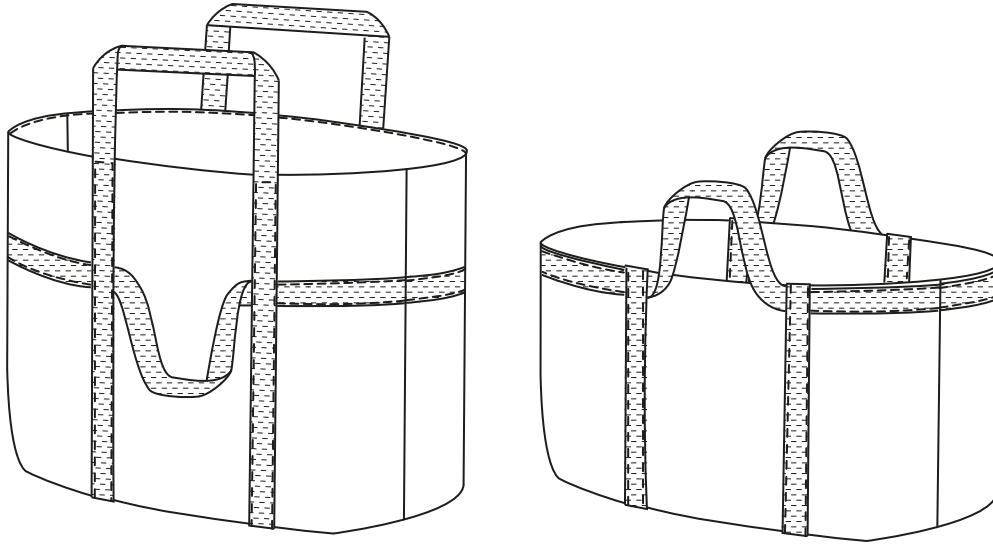

FINISHED MEASUREMENTS FOR THE ONE AND A HALF BAG IN CMS (NOT INCLUDING HANDLES)

**LENGTH (MEASUREMENT TAKEN FLAT)**

55cms

**WIDTH (MEASUREMENT TAKEN FLAT)**

62cms

## **THE ONE AND A HALF BAG**

80CMS WIDE, WITHOUT NAP \*

1.45M

130 - 150CMS WIDE, WITHOUT NAP \*

0.8M

## **WEBBING**

5.3M

\*These are tight lays, measure your fabric and take care with fabrics with a deep selvedge.

# MERCHANT & MILLS

DRAPER

ENGLAND

PATTERN FOR PERSONAL USE ONLY  
NOT TO BE USED FOR MANUFACTURE.

© MERCHANT & MILLS 2015