

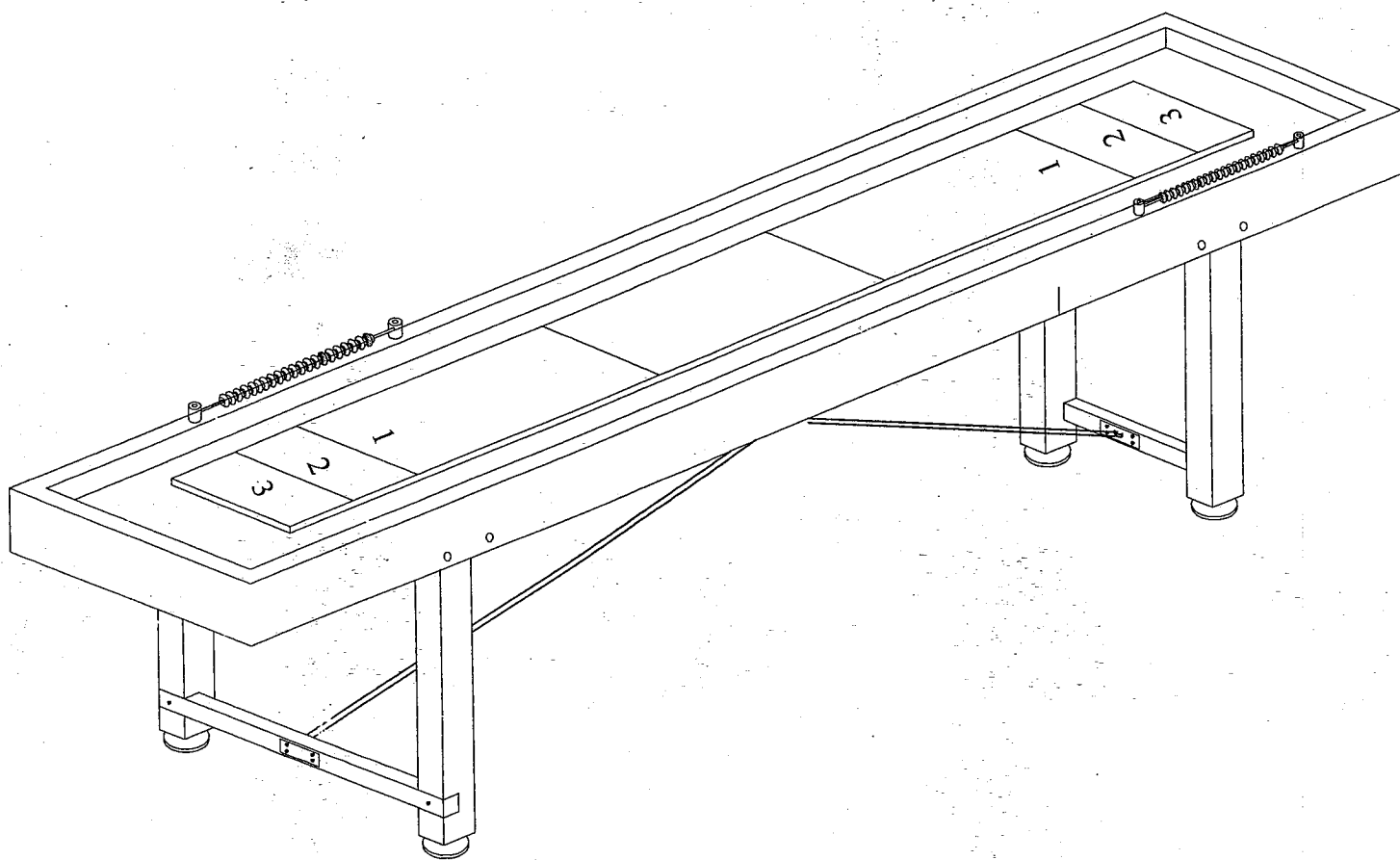

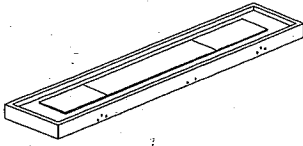

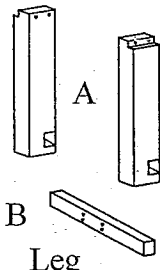

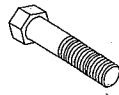
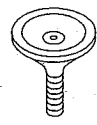
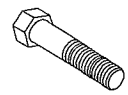

INSTRUCTION MANUAL FOR SHUFFLEBOARD

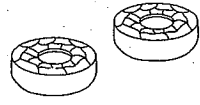
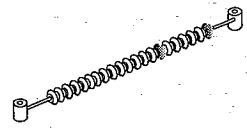

ASSEMBLY INSTRUCTION

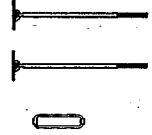
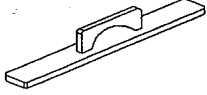
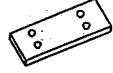
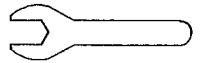
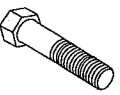
<p>#1</p>  <p>Cabinet 1 pcs</p>	<p>#2</p>  <p>A B Leg 2 set</p>	<p>#3</p>  <p>1/4"*3/4" Bolt 8 pcs</p>	<p>#4</p>  <p>Leg Leveler 4 pcs</p>	<p>#5</p>  <p>1/4"*3" Bolt 12 pcs</p>
<p>#6</p>  <p>1/4"*19mm Washer 28 pcs</p>	<p>#7</p>  <p>Red and blue puck each 4 pcs</p>	<p>#8</p>  <p>Wooden scorer 2 set</p>	<p>#9</p>  <p>Screw F4*1-1/2" 4 pcs</p>	<p>#10</p>  <p>1/4Nut 8 pcs</p>
<p>#11</p>  <p>Wood cap 4 pcs</p>	<p>#12</p>  <p>Lama 2 set</p>	<p>#13</p>  <p>Wiper 1 pcs</p>	<p>#14</p>  <p>Gaskets 2 pcs</p>	<p>#15</p>  <p>Wrench 1 pcs</p>
<p>#16</p>  <p>5/16"*4" Bolt 8 pcs</p>	<p>#17</p>  <p>5/16"*23mm Washer 8 pcs</p>	<p>#18</p>  <p>1/4Wrench 1 pcs</p>		

ASSEMBLY INSTRUCTION

Step 1: Assembly of Legs

*Use blot(#16) and washer(#17) to fix leg(A) to cradle(#1), then install leg levelers(#5) on leg(A) post.

*Use blot(#5) and washer(#6) to fix leg(B) to leg(A).

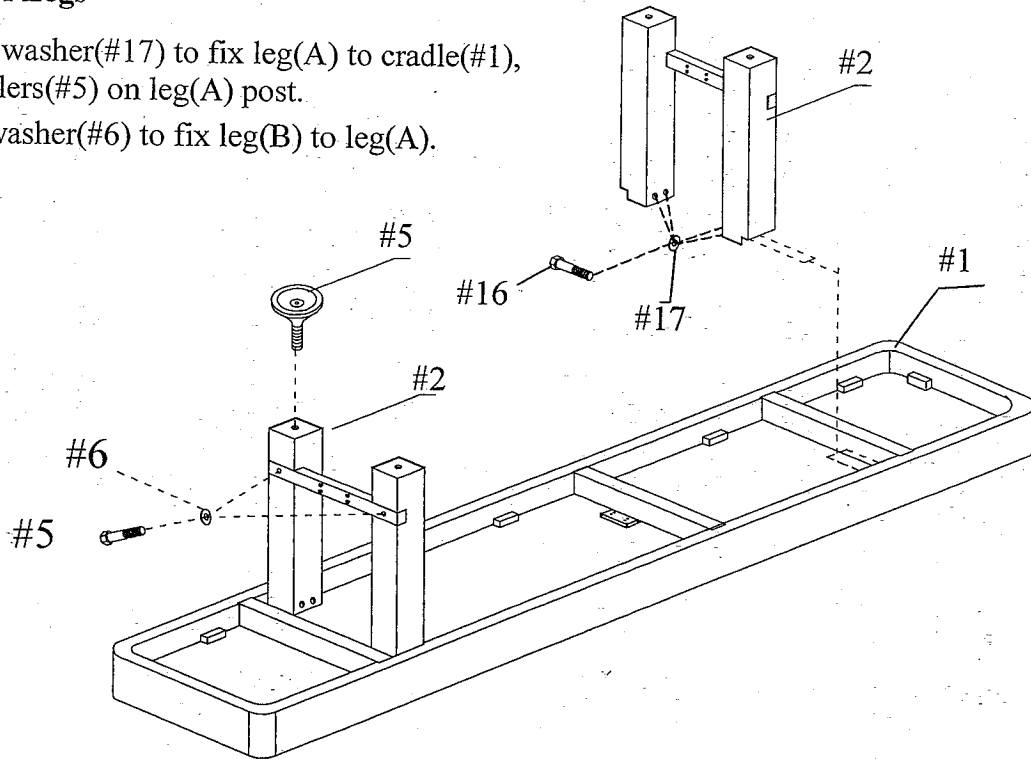

Step 2: Turn the table right side up, use screw(#10) to fix slide scoring unit to cradle(#1), then put on wood cap(#11) to hide the screws.

Step 3: Fix the Lama(#12) on the cradle, Gaskets and washer(#6) and screws(#5) and screws(#3) and nut (#10).

