

INSTRUCTION MANUAL

FOR SHUFFLEBOARD

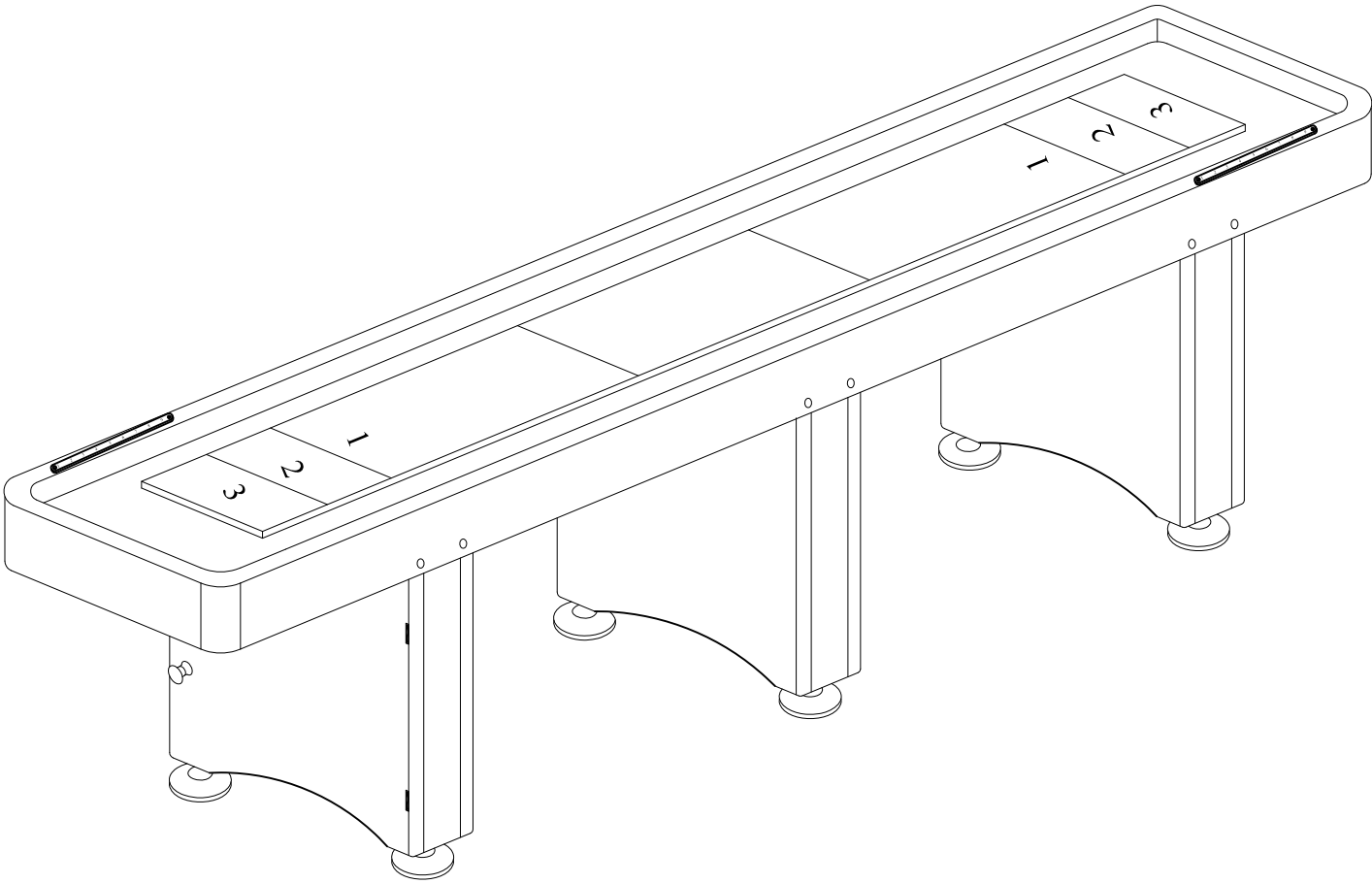

ASSEMBLY INSTRUCTION

#1

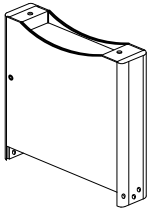

Leg 01
1 pc

#2

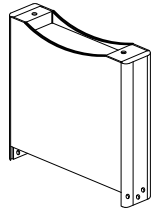

Leg 02
2 pcs

#3

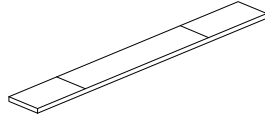

Board
1 pc

#4



Leg Leveler
6 pcs

#5



3/8"*3" Bolt
12 pcs

#6

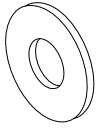

3/8"*23mm Washer
12 pcs

#7

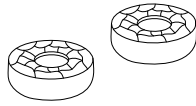

Red and blue puck
each 4 pcs

#8

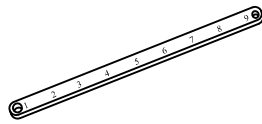

counters
2 pcs

#9

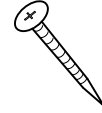

T3*12
4 pcs

#10



Nut
12 pcs

#11

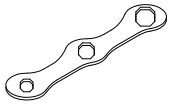

Wrench
1 pc

#12

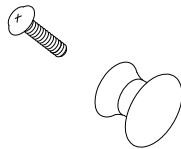

Handle
1 set

#13

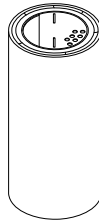

Shuffleboard speed wax
1 pc

#14

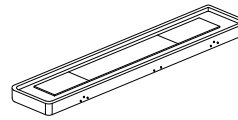

Cabinet
1 pc

ASSEMBLY INSTRUCTION

Step 1: Assembly of Legs

* Use blot(#5) and washer(#6) and nuts (#10) to secure leg 01(#1) and leg 02(#2) to cabinet(#14) as shown in the figure 1.

* Install leg levelers(#4) as shown in the figure 1.

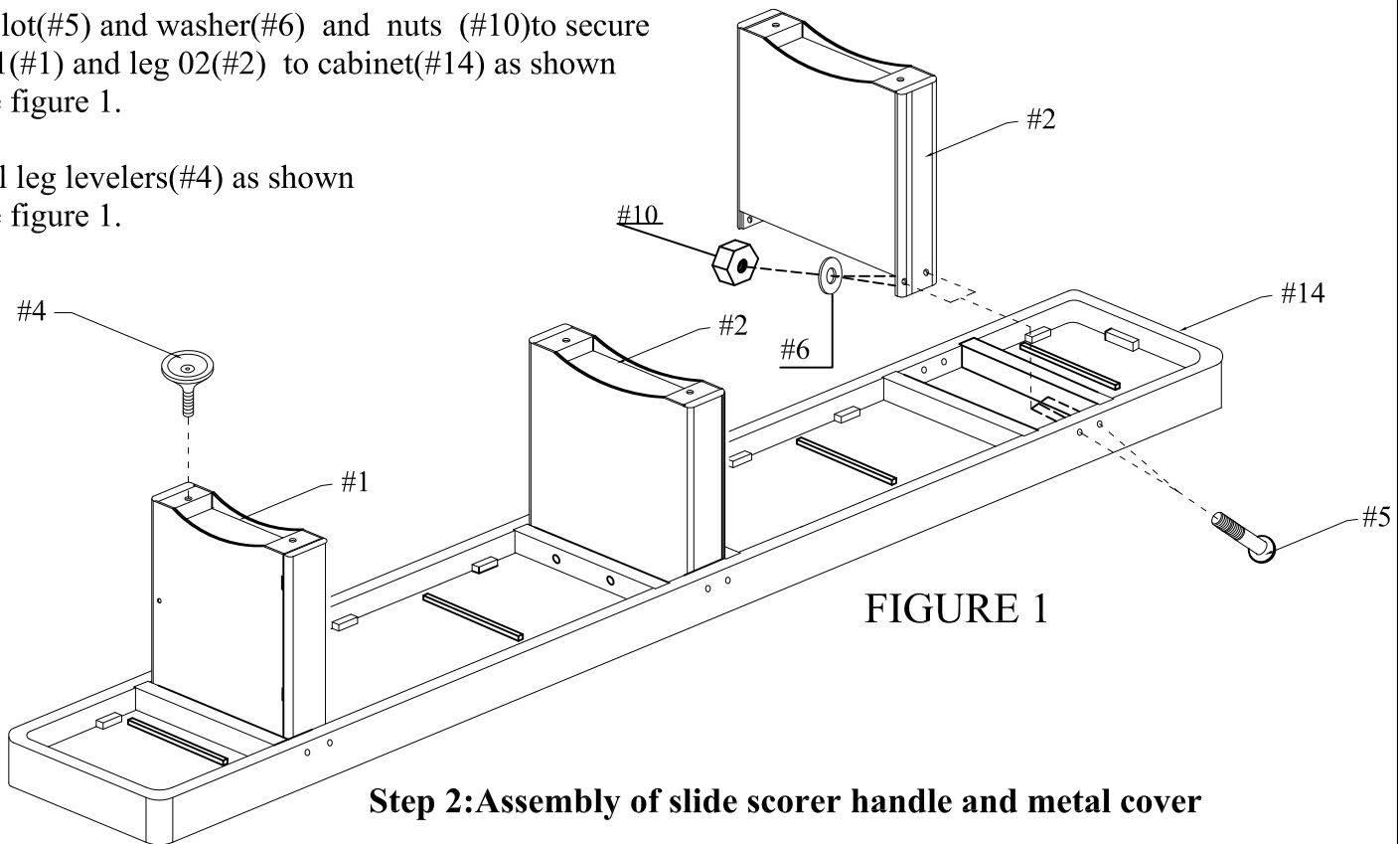

FIGURE 1

Step 2: Assembly of slide scorer handle and metal cover

NOTE: Do not allow the weight of the table to rest on the side of the legs. Use two person or more persons to turn the table right side up.

- * Use blot to handle(#12) to secure leg 01(#1) as shown in the figure 2.
- * Use screw(#9) to attach the counters(#8) to the cabinet as shown.

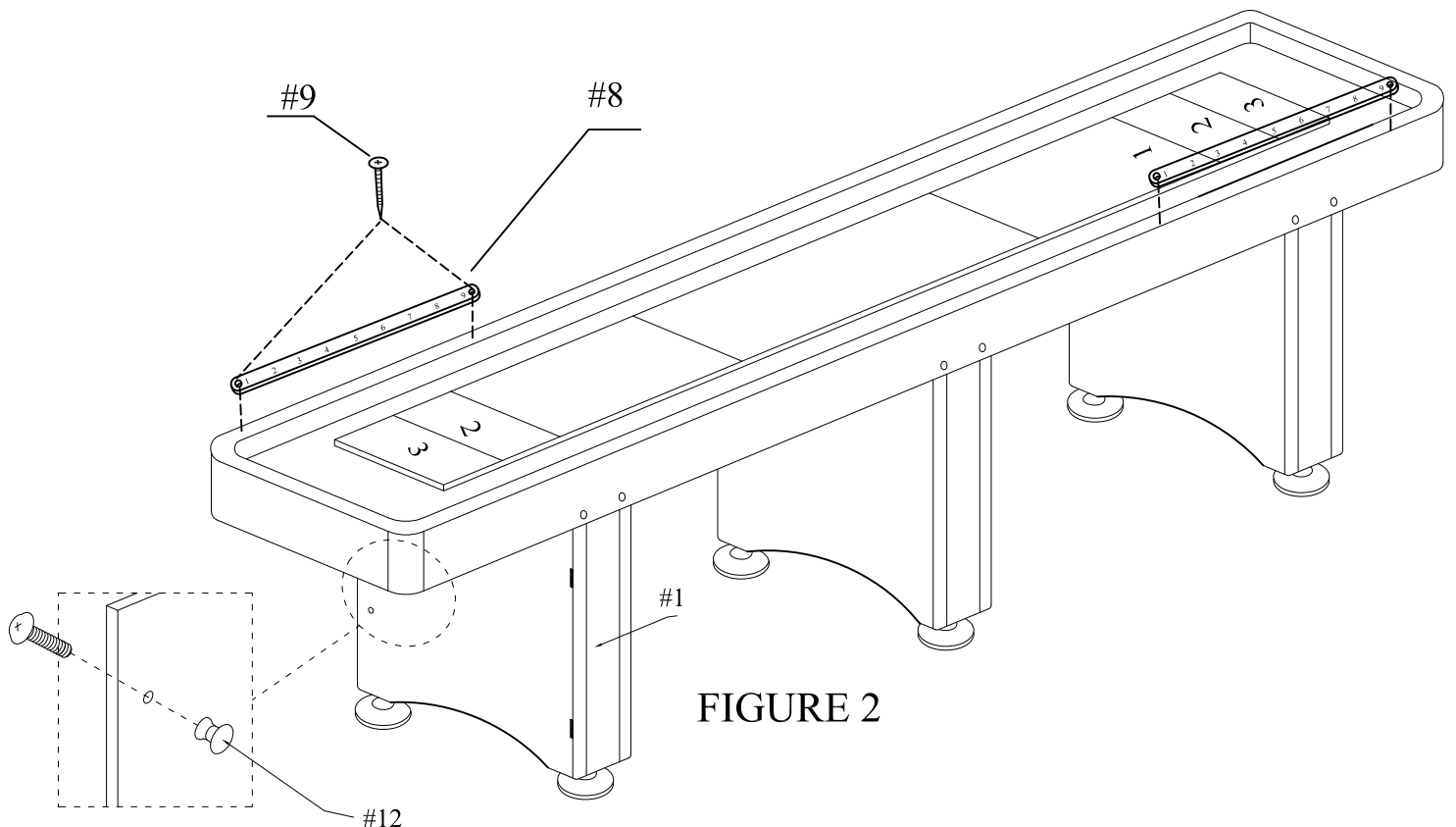

FIGURE 2