

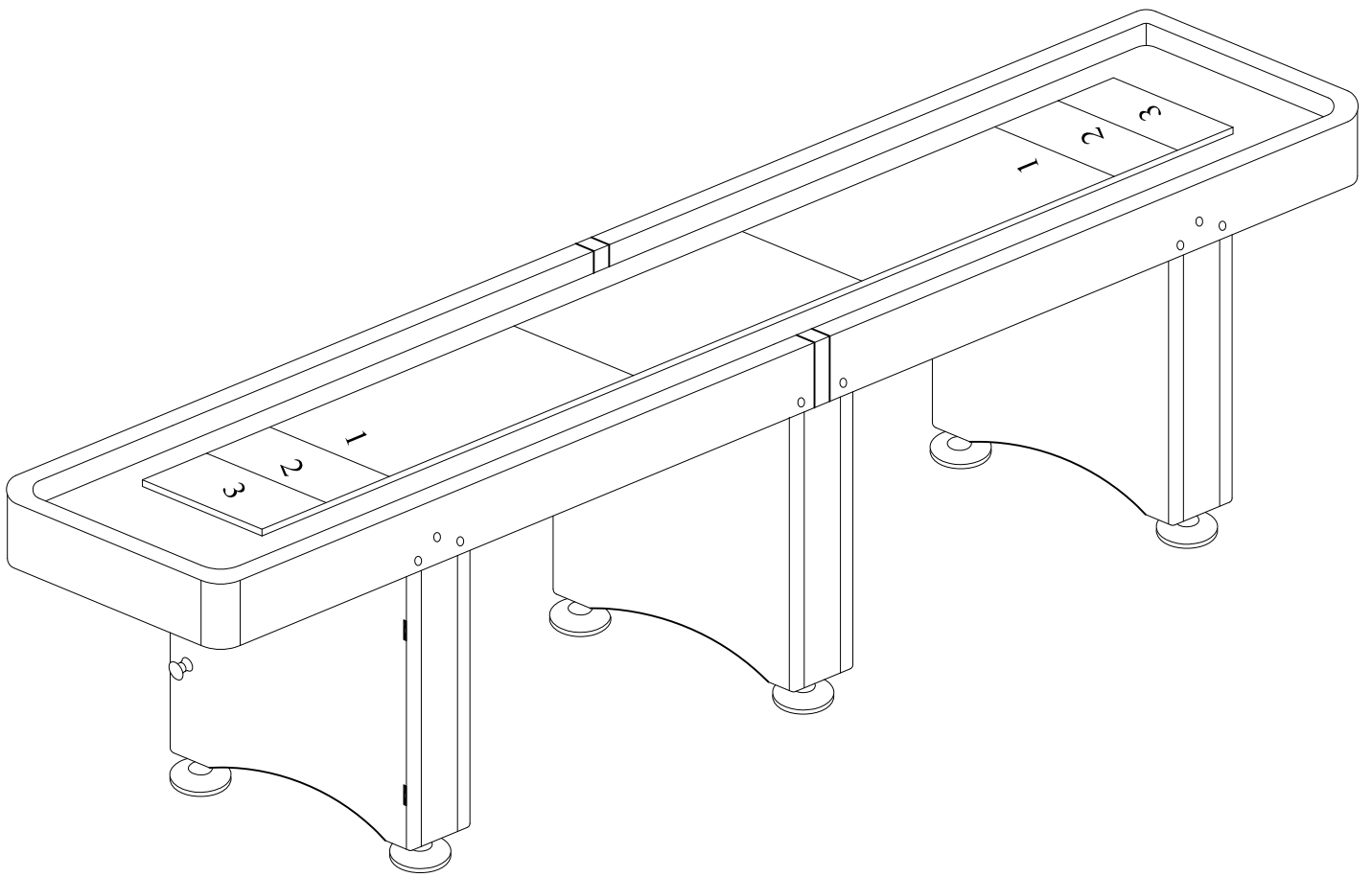

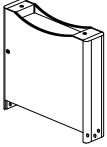

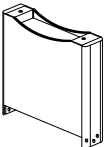

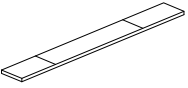



INSTRUCTION MANUAL FOR SHUFFLEBOARD

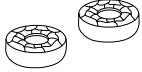
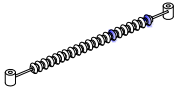

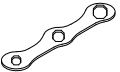
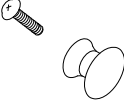
ASSEMBLY INSTRUCTION

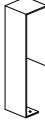
<p>#1  Leg 01 1 pc</p>	<p>#2  Leg 02 2 pcs</p>	<p>#3  Board 1 pc</p>	<p>#4  Leg Leveler 6 pcs</p>	<p>#5  5/16"*2-1/4" Bolt 16 pcs</p>
<p>#6  5/16"*23mm Washer 16 pcs</p>	<p>#7  Red and blue puck each 4 pcs</p>	<p>#8  Slide scoring unit 2 set</p>	<p>#9  Screw F4*1-1/2" 4 pcs</p>	<p>#10  Wood cap 4 pcs</p>
<p>#11  Wrench 1 pc</p>	<p>#12  Handle 1 set</p>	<p>#13  Shuffleboard speed wax 1 pc</p>	<p>#14  Metal cover 2 pcs</p>	<p>#15  Screw F3*12mm 4 pcs</p>
<p>#16  Cabinet 1 pc</p>				

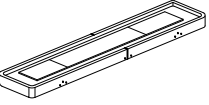
ASSEMBLY INSTRUCTION

Step 1: Assembly of Legs

* Use blot(#5) and washer(#6) to secure leg 01(#1) and leg 02(#2) to cabinet(#16) as shown in the figure 1.

* Install leg levelers(#4) as shown in the figure 1.

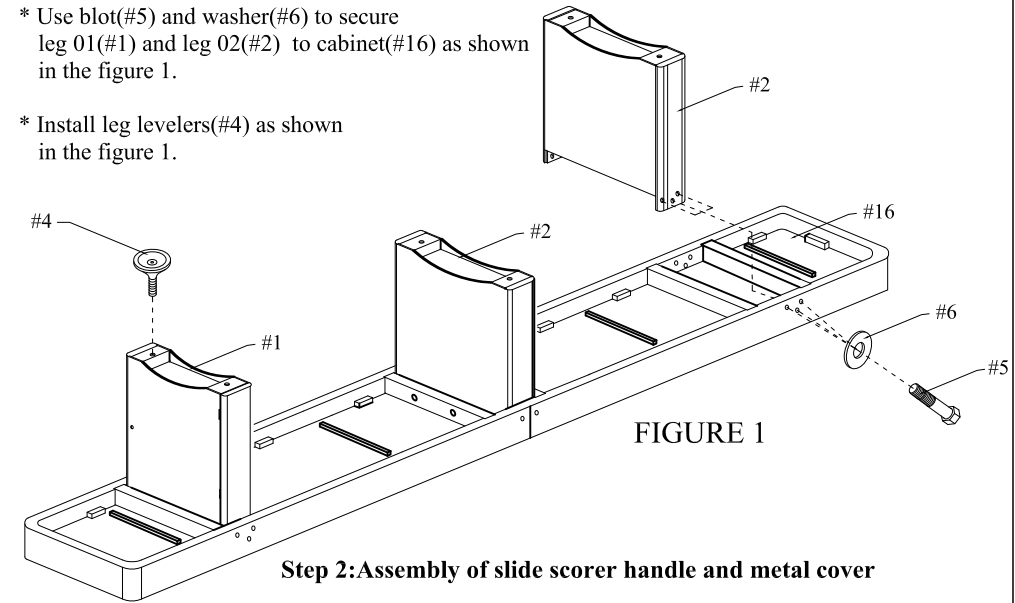

Step 2: Assembly of slide scorer handle and metal cover

NOTE: Do not allow the weight of the table to rest on the side of the legs. Use two person or more persons to turn the table right side up.
 * Use blot to handle(#12) to secure leg 01(#1) as shown in the figure 2.
 * Use screw(#9) to attach the wood scorer(#8) to the cabinet as shown.
 * Put the wood cap(#10) into screw holes.
 * Fix metal cover (#14) with screw (#15) as shown in the picture 2.

