

Use a hex wrench to adjust the damp for swiveling. Turn counter-clockwise to reduce damping and clockwise to increase damping.

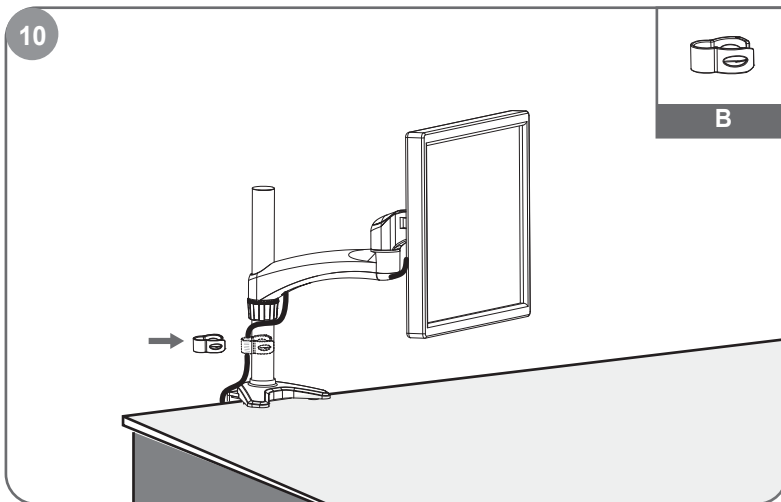

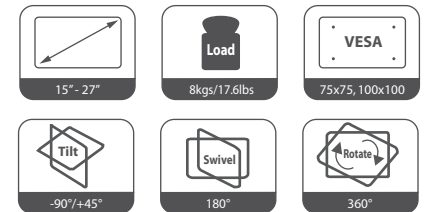



Insert cables into cable covers.  
Use cable clamp to limit cables close to steel pipe.



# Installation INSTRUCTIONS

## WARNING STATEMENTS

### Warning

-  Prior to the installation of this product, the installation instruction must be read and completely understood. Failure to do so may result in personal injury, property damage or voiding of factory warranty.
-  Do not install on a structure that is prone to vibration, movement or chance of impact. Reinforce the structure as required before installation.
-  Recommended mounting surfaces: Wooden studs or solid-flat concrete. If the mount is to be installed on any surface other than wooden studs, use suitable hardware.
-  Pay attention to the weight capacity of the mount. Exceeding the limitation can result in function unworkable or even serious personal injury and property damage.
-  Never operate the mount if parts are missing or damaged. Contact your local service center for warranty service.

## PRODUCT LINE GRAPH

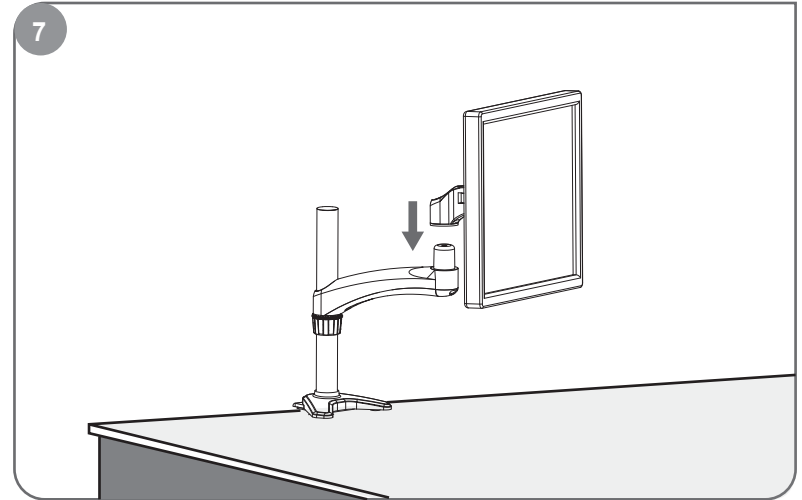
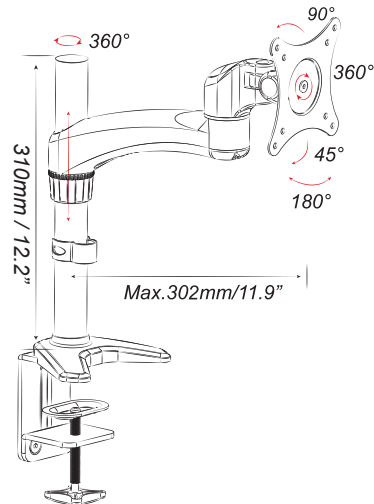

Lift the plate connecting part along with the monitor and put it on the extension arm.

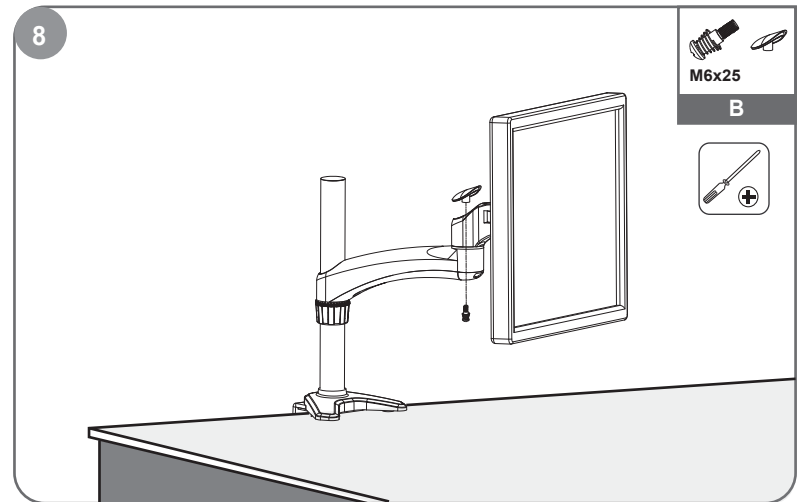

Insert the screw through the hole from extension arm to the decorative cap.

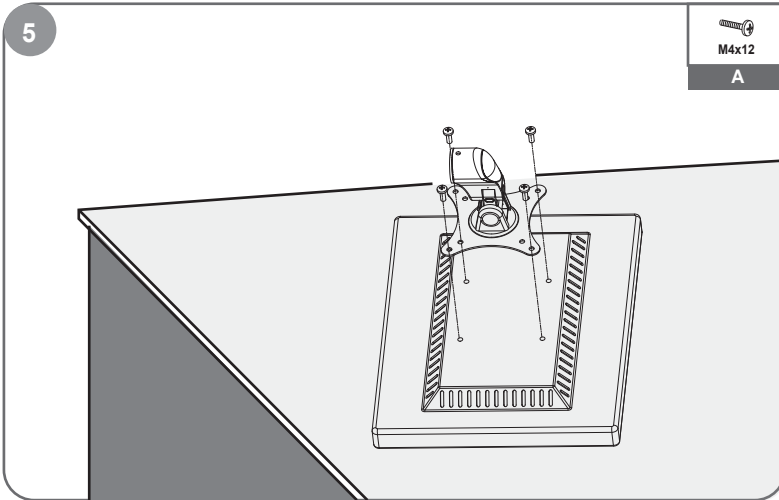

Flush surface installation: Install 4 screws through faceplate to monitor via mounting holes.

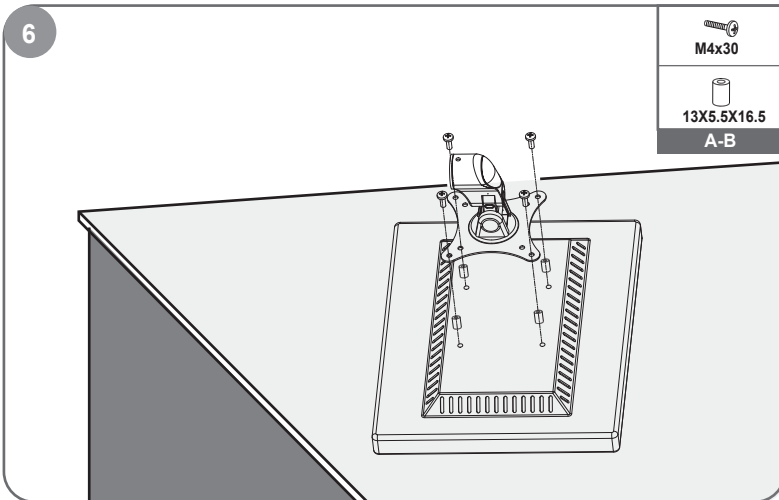





Recessed surface installation: Put 4 spacers between faceplate and monitor. Install 4 screws through faceplate, spacers to monitor via mounting holes.



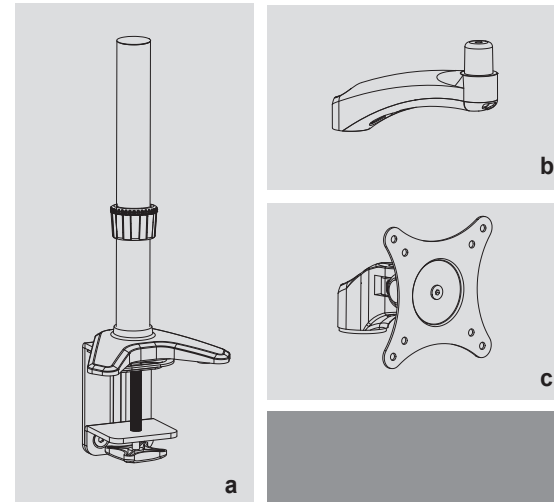

## TOOLS REQUIRED NOT INCLUDED



## PARTS INCLUDED



A	 M4x12 (x4)	 M4x30 (x4)
	 S=3mm (x1)	 S=5mm (x1)

B	 13X5.5X16.5 (x4)	 (x1)
	 M6x25 (x1)	 (x1)

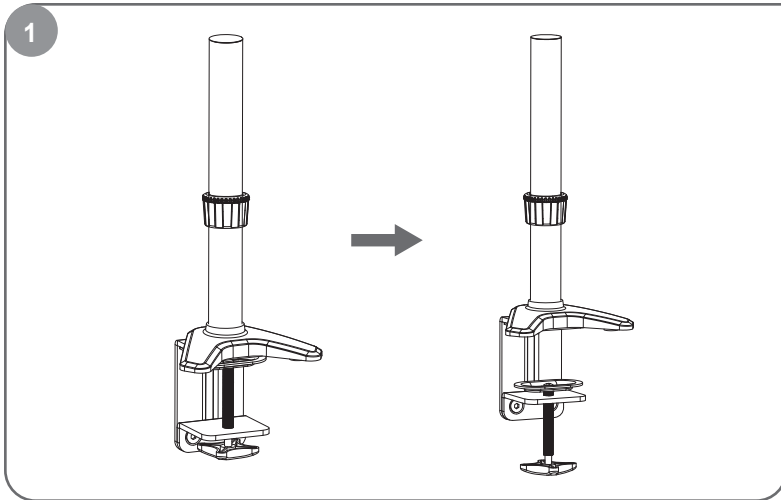

Loosen clamp screw until enough space is left for the edge of the desk.

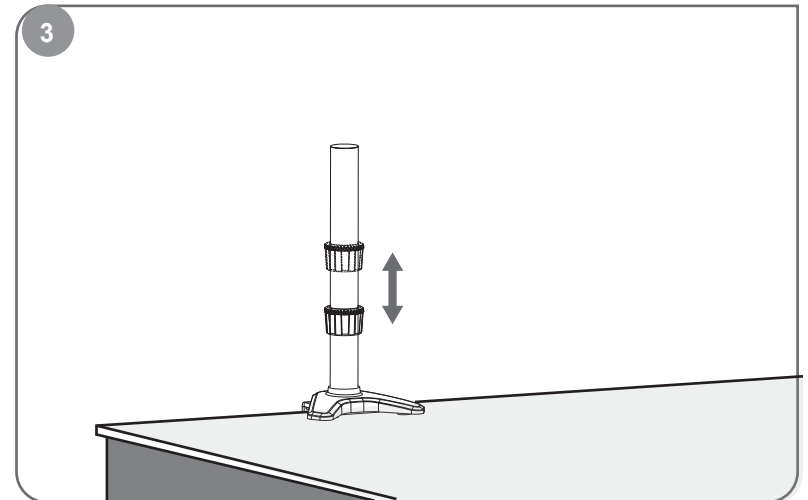

Adjust locating ring at proper height and screw up tight to hold the mount.

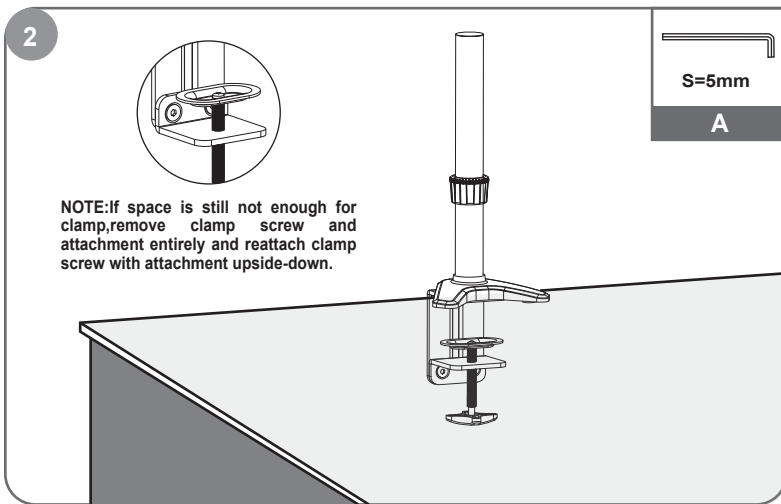

Tighten clamp using clamp screw until mount is securely fastened to

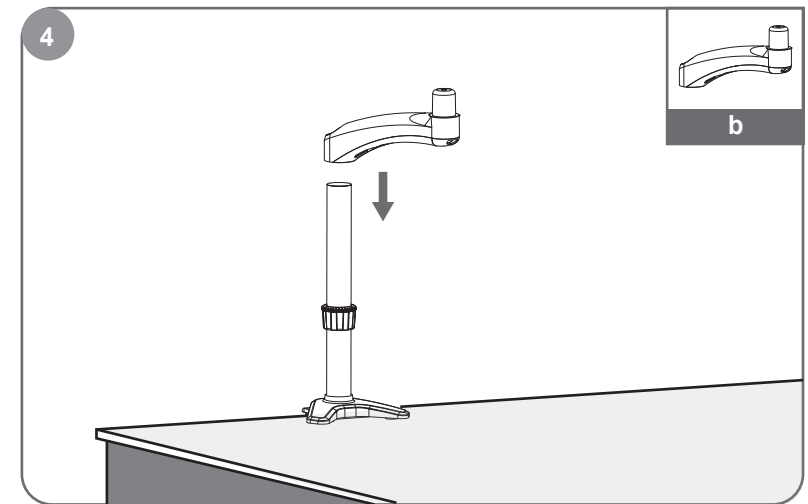

Insert extension arm to the steel pipe above the locating ring.