

Telescopic Cylinder

Models

EF-07-90-SK
EF-07-120-SK
EF-07-135-SK

EF-12-108-SK
EF-12-120-SK
EF-12-144-SK

Operator's Manual and Installation Instructions

Primary Mover
8361 Commercial Way South
Mandeville, LA 70471
985-888-6554
www.primarymover.com

Table of Contents

Introduction	3
Important Information	3
Message to the Trailer Manufacturer	3
Warranty	4
Safety First.....	5
Safety Sign Locations	5
Safety Precautions	6
Parts Included in Telescopic Cylinder Kit	7
Safety Arm Installation and Use	8
Hinge Installation and Lubrication	10
Telescopic Cylinder Location on Trailer	11
Trailer Capacity and Dump Angle	12
Single Acting Hydraulic Power Unit Installation.....	15
Hydraulic System Pre-Operation	15
Telescopic Cylinder Bleed Procedure	17
Battery Hookup Single Acting HPU	18
Troubleshooting	19

Introduction

This manual covers proper cylinder installation, hydraulic connection, wiring and service of the Primary Mover models listed on the cover. **NOTICE: It is the end users responsibility to determine appropriate support member strength and weld size to properly support the load being lifted. Illustrations are for instructional purposes only.**

Important Information

Kit Serial Number	
Pump Installation and Operation Manual Number:	
In Service Date:	
Dealer:	
Address:	
City, State, Zip:	
Dealer Phone Number:	

Message to the Trailer Manufacturer

This manual contains instructions on how to correctly install and operate the Telescopic Cylinder system. These instructions are generalized, as each trailer is manufactured differently.

This manual does not outline the operation of the hydraulic system, as there are many different types of hydraulic systems available and supplied by Primary Mover. **It is important that the hydraulic system operation manual be supplied to the end user, along with this manual.**

Some trailer manufactures will purchase and install a hydraulic system not supplied by Primary Mover. In this case, it is your responsibility to obtain the correct manual for the installation and operation of the hydraulic system. **The hydraulic system manual should be supplied along with this manual and made available to the end user.**

The safety signs supplied with the kit are general in nature and are for use with the kit. Because trailers vary between manufactures, it is the responsibility of the manufacturer, not Primary Mover, to ensure that correct safety signs and warnings are obtained.

Warranty

Standard Warranty:

Primary Mover warrants your product to be free from defects in material and workmanship for a period of 36 months from the original date of purchase. If you discover a defect in a product covered by this warranty, we will repair at our option using new or refurbished components, or if repair is not possible, replace the item. This warranty is non-transferable.

Warranty Extension:

Primary Mover warrants for 5 years from the date of purchase any of its kits that have the three products listed below in the circuit and have a hydraulic fluid pre-filtration process in place. The hydraulic fluid must be pre-filtered while being put into the hydraulic pump reservoir, with a FPH cleanliness code of at least (ISO 4406) 15/12. (Contact Primary Mover for instructions on how to implement these quality control measures).

PM power unit (single or double acting, "with a ground wire connected directly from the battery post to the electric motor of the pump").
Bridon Load Control Valve (on the load holding port)
SP-7 SolarPulse Solar Panel (mounted per our recommendation)

Exclusions:

This warranty covers defects in manufacturing discovered while using the product as recommended by the manufacturer. The warranty does not cover loss or theft, nor does coverage extend to damage caused by misuse, improper installation, abuse, unauthorized modification, improper storage conditions, or natural disasters. This warranty does not cover parts that are subject to normal wear and tear. Paint, finishes or paint preparation done by the customer are not covered under this warranty, nor is deterioration of the paint and appearance caused by normal wear and tear. This warranty becomes void upon modifications not authorized by Primary Mover.

Limits of Liability:

Should the product fail, your sole recourse is repair or replacement, as described in preceding paragraphs. Primary Mover will not be liable to you or any other party for damages resulting from failure of the product. Damages not covered by this warranty include, but are not limited to, lost profits, lost savings, damage to other equipment, incidental or consequential damages arising from the use or inability to use this product. In no event will Primary Mover be liable for more than the amount of your purchase price, not to exceed the current list price of the product and excluding tax, shipping and handling charges. By using this product, user accepts all terms stated herein.

Primary Mover reserves the right to make improvements to any model or product without notice. This warranty supersedes all previous warranties written or implied.

Safety First

 This symbol is used to call attention to instructions concerning personal safety. Be sure to observe and follow these instructions. Take time to be careful!

A brief description of signal words that are used in this manual follows:

 **DANGER** indicates an imminently hazardous situation which, if not avoided, WILL result in death or serious injury.

 **WARNING** indicates a potentially hazardous situation which, if not avoided, COULD result in death or serious injury and includes hazards that are exposed when guards are removed.

 **CAUTION** indicates a potentially hazardous situation which, if not avoided, MAY result in minor or moderate injury. It is also used to alert against unsafe practices.

Safety Sign Locations

Safety signs are included with the hoist kit purchased by you or the trailer manufacturer. Place these signs as shown below.

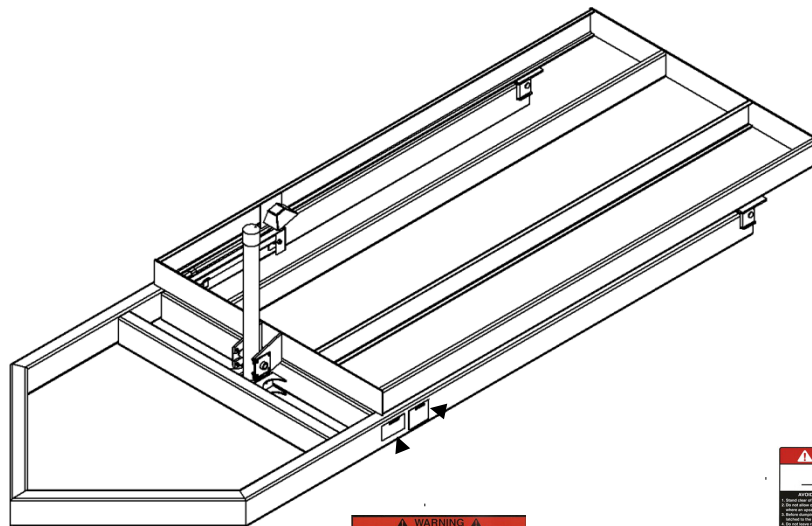

Part 170036
Locate as shown



Part 170019
Locate in an easy-
location here and
on opposite frame

 Read all safety signs on the trailer and in this manual. Keep these signs clean and replace any lost or destroyed signs.

Safety Precautions

⚠️ WARNING Installing or operating this equipment without first understanding proper installation and operation procedures could lead to serious injury or death. Always read and fully understand all installation and operation manuals before installing or operating this equipment. Contact Primary Mover with any questions.

⚠️ WARNING Overloading a trailer could cause vehicle or trailer component damage resulting in injury or death. NEVER exceed the gross vehicle weight (GVW) or gross axle weight (GAW) rating of the trailer or your vehicle.

⚠️ WARNING Damage to brake lines during manufacturing and installation of this equipment, as well as installing any hardware (bolts, nuts, brackets) in a way that they may rub and damage the brake system, could lead to brake failure. This can cause an accident that could cause injury or death. ALWAYS take adequate steps to prevent brake system damage during installation of the equipment, and take precaution to ensure that installed equipment does not interfere with brake system.



⚠️ WARNING Malfunctioning equipment could cause property damage, injury or death. ALWAYS have faulty equipment repaired before continuing use. Consult the trailer manufacturer if required.

⚠️ WARNING Welding, oxy-fuel cutting, or grinding could cause fuel to ignite. This could lead to injury or death. ALWAYS take adequate steps to avoid the ignition of fuel from fuel tanks when welding, oxy-fuel cutting, and/or grinding during installation.

⚠️ WARNING Heat from the vehicles exhaust system could cause hydraulic component failure. This could lead to a fire that can lead to injury or death. ALWAYS install equipment in locations where the exhaust system heat will not damage any components critical to operation.

⚠️ WARNING Never attempt to jerk or shock the trailer body with the body raised to remove a stuck load. Jerking or shocking the trailer in this position can cause damage that could result in injury or even death. NEVER drive forward or reward and stop quickly to “un-stick” the load. If load is stuck, lower trailer body and free load

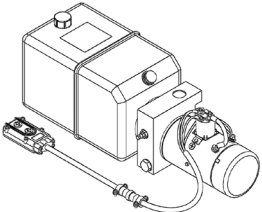
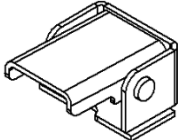
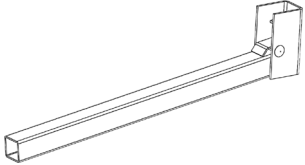
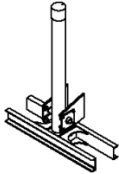
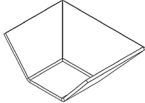
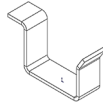
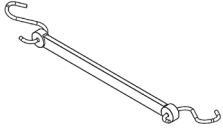
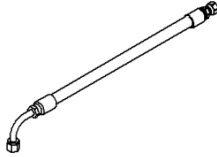
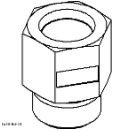
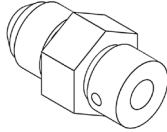
Parts Included in Telescopic Cylinder Kit

 <p>Hydraulic Power Unit (HPU) Single Acting</p>	 <p>Two Hinges (Styles Vary)</p>
 <p>Safety Arm</p>	 <p>Cylinder and Mount</p>
 <p>Safety Arm Cup</p>	 <p>Safety Arm Storage Arm Bracket</p>
 <p>Rubber Battery Strap</p>	 <p>Hydraulic Hose Between HPU & Cylinder One 1/2" x 120" Long</p>
 <p>Hydraulic Fittings</p>	 <p>Bridon Load Control</p>
 <p>Two Battery Cables 2GA. X 16"</p>	 <p>Safety Signs</p>

Safety Arm Installation and Use



Always support an unloaded body with the safety arm. The safety arm is meant to support the weight of an unloaded body only.



Being under a raised body could result in serious injury or death should the body unexpectedly descend. Never position yourself or allow others to position themselves under a loaded body. Always support an unloaded body with the supplied safety arm. NEVER use the safety arm on a loaded body.

Safety Arm Use:

- 1 Raise trailer body to sufficient height and shut off hydraulic power to hoist.
- 2 Grasp safety arm and rotate into the up/vertical position.
- 3 Once vertical position is accomplished, push arm down into the support bracket at base of arm.
- 4 **SLOWLY** lower the body until the cup contacts the vertical facing arm.
- 5 **NEVER HOLD DOWN THE DOWN BUTTON** on the remote control after the body contacts the safety arm. Doing so will bend the safety arm or bracket.
- 6 Reverse the above procedure to place arm back in its hanger for transport (be sure to body to full down position upon placing arm back in hanger).

Maximum Unloaded Tilt Body Weight in Pounds Using One Safety Arm

		Trailer tilt body length in feet						
		8	10	12	14	16	18	20
Distance between rear hinge and safety arm in inches	50	3854	3083	2569	2202	1927	1713	1542
	60	4625	3700	3083	2643	2313	2056	1850
	70	5396	4317	3597	3083	2698	2398	2158
	80	6167	4933	4111	3524	3083	2741	2467
	90	6938	5550	4625	3964	3469	3083	2775
	100		6167	5139	4405	3854	3426	3083
	110		6783	5653	4845	4240	3769	3392
	120		7400	6167	5286	4625	4111	3700
	130			6681	5726	5010	4454	4008
	140			7194	6167	5396	4796	4317
	150				6607	5781	5139	4625
	160				7048	6167	5481	4933
	170					6552	5824	5242
	180					6938	6167	5550
	190					7323	6509	5858
	200						6852	6167
210						7194	6475	
220							6783	
230							7092	

Primary Mover
Mandeville, LA

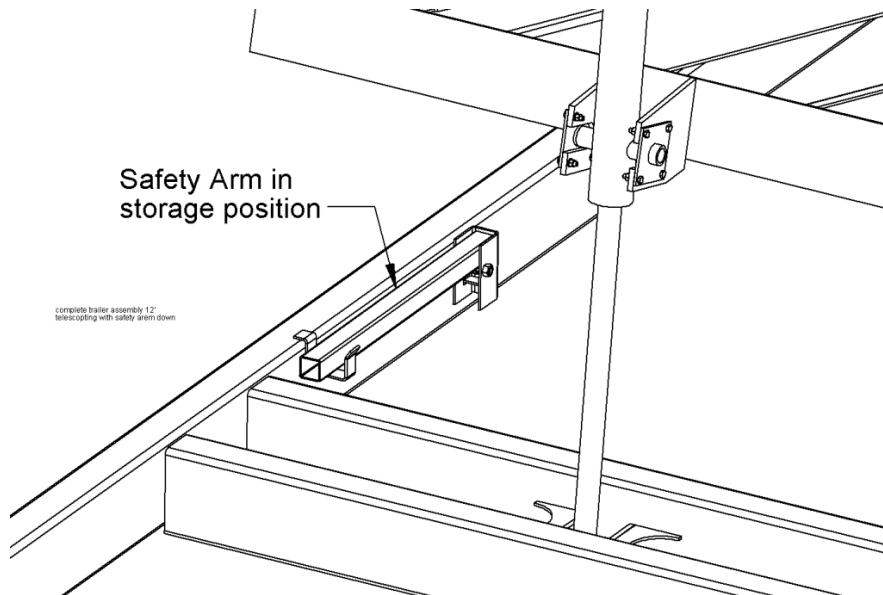
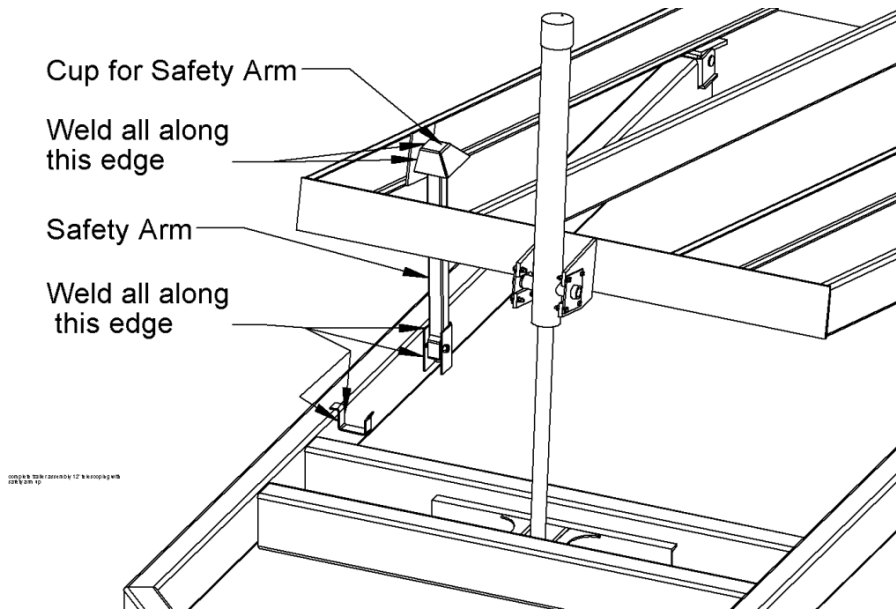

Hinge Installation and Lubrication

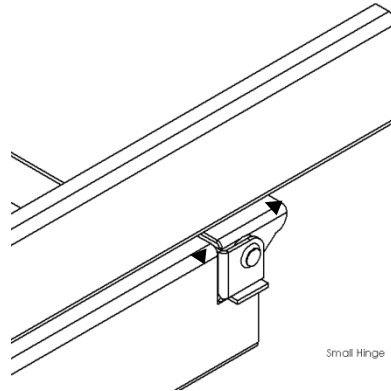

Mount hinge so pad of hinge is level with trailer frame.

Center hinge on support and weld hinge to support at all contact surfaces.

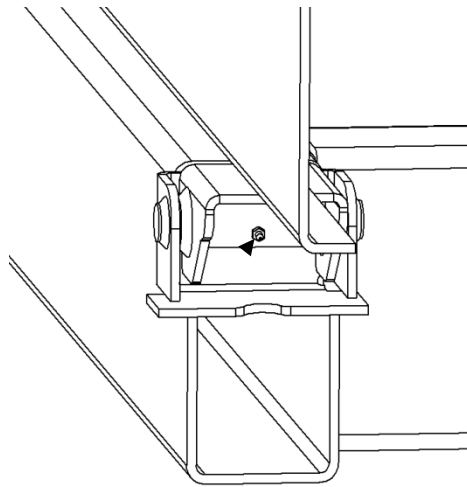

small hinge grease

Lubricate the joint with EP3 grease every 6 months

Telescopic Cylinder Location on Trailer

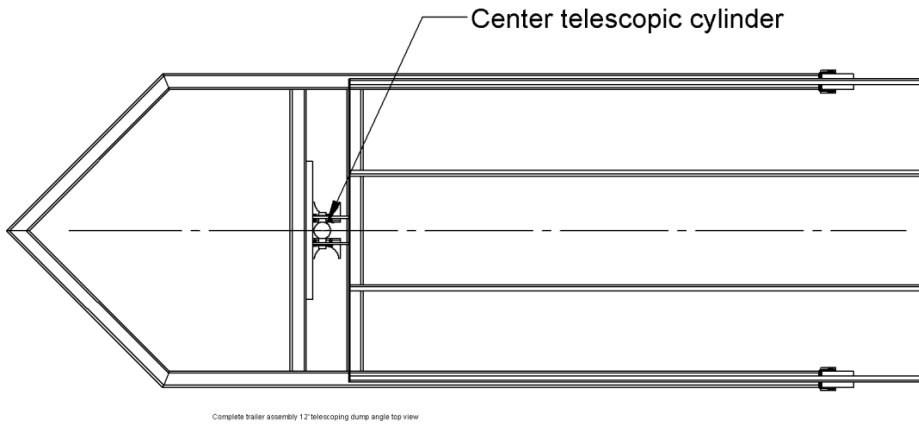
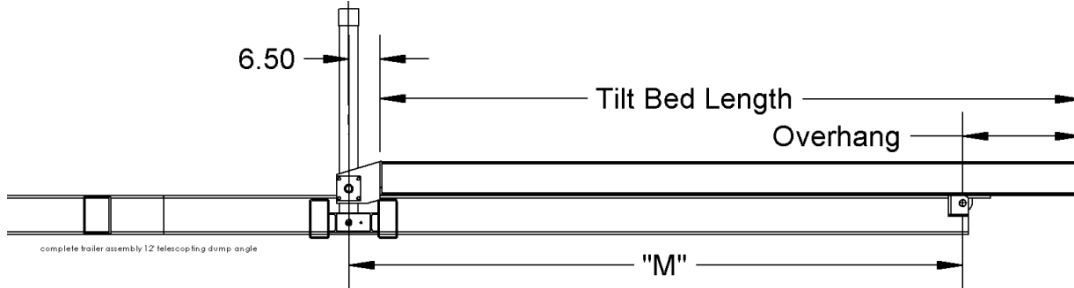

Trailer Capacity and Dump Angle

Capacity and dump angle are approximate. Capacity is calculated using a evenly dis-tributed load.

⚠️WARNING

The telescopic cylinder is capable of:
14,000 lbs. of push for EF-07-90-SK thru EF-07-135-SK
24,000 lbs. of push for EF-12-108-SK thru EF-12-144-SK

Improper sizing, mounting, and welding of the cylinder supports could result in support failure.

EF-07-90-SK (14,000 lbs. x 90" Stroke)				
Tilt Bed (Feet)	Overhang (Inches)	"M" Dimension (Inches)	Max. Dump Angle (Degrees)	Capacity (Tons)
10	12	114.5	46	16.8
	18	108.5	49	18.1
	24	102.5	52	20.0
12	12	138.5	38	16.2
	18	132.5	40	17.2
	24	126.5	42	18.4

EF-07-108-SK (14,000 lbs. x 108" Stroke)				
Tilt Bed (Feet)	Overhang (Inches)	"M" Dimension (Inches)	Max. Dump Angle (Degrees)	Capacity (Tons)
10	12	114.5	56	16.8
	18	108.5	60	18.1
	24	102.5	64	20.0
12	12	138.5	45	16.2
	18	132.5	47	17.2
	24	126.5	49	18.4
14	12	162.5	39	15.8
	18	156.5	41	16.6
	24	150.5	43	17.5

EF-07-135-SK (14,000 lbs. x 135" Stroke)				
Tilt Bed (Feet)	Overhang (Inches)	"M" Dimension (Inches)	Max. Dump Angle (Degrees)	Capacity (Tons)
12	12	138.5	58	16.8
	18	135.5	61	18.1
	24	126.5	64	20.0
14	12	162.5	48	16.2
	18	156.5	50	17.2
	24	150.5	52	18.4
16	12	186.5	40	15.8
	18	180.5	42	16.6
	24	174.5	44	17.5

Primary Mover
Mandeville, LA

EF-12-108-SK (24,000 lbs. x 108" Stroke)				
Tilt Bed (Feet)	Overhang (Inches)	"M" Dimension (Inches)	Max. Dump Angle (Degrees)	Capacity (Tons)
10	12	114.5	56	28.6
	18	108.5	60	31.0
	24	102.5	64	34.4
12	12	138.5	45	27.7
	18	132.5	47	29.4
	24	126.5	49	31.6
14	12	162.5	39	27.0
	18	156.5	41	28.4
	24	150.5	43	30.1

EF-12-120-SK (24,000 lbs. x 120" Stroke)				
Tilt Bed (Feet)	Overhang (Inches)	"M" Dimension (Inches)	Max. Dump Angle (Degrees)	Capacity (Tons)
12	12	138.5	51	27.7
	18	132.5	54	28.4
	24	126.5	57	30.1
14	12	162.5	43	27.0
	18	156.5	45	28.4
	24	150.5	47	30.1
16	12	186.5	37	26.6
	18	180.5	38	27.7
	24	174.5	39	29.0

EF-12-144-SK (24,000 lbs. x 144" Stroke)				
Tilt Bed (Feet)	Overhang (Inches)	"M" Dimension (Inches)	Max. Dump Angle (Degrees)	Capacity (Tons)
14	12	162.5	53	27.0
	18	156.5	55	28.4
	24	150.5	57	30.1
16	12	186.5	45	26.6
	18	180.5	47	27.7
	24	174.5	49	29.0
18	12	210.5	40	26.3
	18	204.5	41	27.2
	24	198.5	42	28.3

Single Acting Hydraulic Power Unit Installation

Mount HPU (hydraulic power unit) in a weather tight enclosure on the trailer. See additional instructions supplied with the HPU for mounting, electrical, wireless remote and hydraulic fluid requirements.

All HPU, hoses and fittings between HPU and cylinder are supplied by Primary Mover.

⚠ CAUTION If hydraulic components other than those supplied by Primary Mover are used in the hydraulic circuit, it is the purchaser's responsibility to verify that the components are compatible with the components supplied by Primary Mover. Incompatible components may cause failure of the direct push cylinder that, in turn, may cause damage to the trailer, vehicle, other property, and may cause injury or death.

⚠ WARNING Connecting the cylinder to a hydraulic system with more pressure (PSI) or flow (GPM) than is recommended by Primary Mover could cause the cylinder to fail during operation. This could lead to damage, serious injury, or death. Be sure you have correct pressure and flow before operation. Consult Primary Mover if you are unsure about your hydraulic system.

⚠ WARNING Adjusting the hydraulic pressure to more than the recommended setting could cause the cylinder to fail during operation. This could cause damage, serious injury, or death. NEVER adjust the pressure on your own. Consult the trailer manufacturer if the hydraulic pressure is in question. Only qualified personnel should adjust the hydraulic pressure. NEVER adjust the pressure to more than the recommended amount.

Hydraulic System Pre-Operation

The hydraulic system supplied by Primary Mover consists of components (pump, valves, reservoir, hoses, cylinder, etc.) that are designed to be compatible with each other.

All Primary Mover's system liability and warranty will be voided, if determined by Primary Mover, that substituted hydraulic components were used that were incompatible with those supplied by Primary Mover.

Hydraulic Power Unit parameters are listed on the next page. These are listed as a general guide to ensure proper compatibility (when using other hydraulic components). If you have any questions, please contact Primary Mover.

Primary Mover
Mandeville, LA

Cylinder Only with Pump 90 Degree

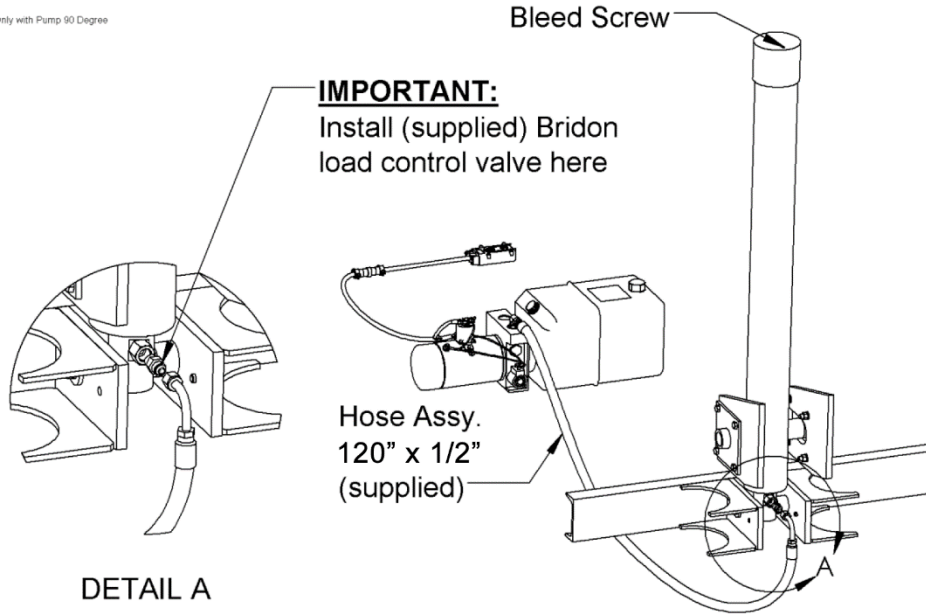

Maximum Hydraulic Flow Rate	2.6 GPM
Maximum Pressure For "Raising" Portion of Cycle	3200 PSI

Telescopic Cylinder Bleed Procedure

1. The highest point of the hydraulic circuit is the telescopic cylinder bleed screw. Remove the bleed screw and sealing washer.
2. Gradually fill the cylinder by pressing the “UP” button on the remote control station. This should be done in an intermittent manner with a rag over the bleed screw hole. Fluid will come out of the bleed screw hole at high velocity if the cylinder is filled too quickly. Keep fluid in the reservoir to prevent air from entering system.
3. Once a steady stream of fluid comes out the bleed screw hole, stop filling and install and tighten bleed screw.
4. Press and hold the “UP” button and keep the oil reservoir filled just enough to keep air out of system. Fully extend the cylinder.
5. Press and hold the “DOWN” button until cylinder is fully retracted. Watch oil reservoir level in case of overflow.
6. To remove any remaining air in the system, fully retract the cylinder and remove bleed screw. Repeatedly tap “UP” button until only fluid is coming out of bleed screw hole. Replace bleed screw.
7. Wipe cylinder clean and replace any lost oil.
8. Fully extend the cylinder. The cylinder should extend smoothly without any jerky motion. Watch oil level in reservoir. If cylinder has a jerky (stop and go) motion, retract the cylinder and repeat steps 6 thru 8 until cylinder operated smoothly.
9. Check oil level in reservoir. Bleed procedure is complete.

Battery Hookup Single Acting HPU

⚠️ WARNING

Shorting of the electrical system could cause a fire or equipment damage that could lead to injury or death. ALWAYS disconnect the battery prior to installing, servicing, or repairing power unit.

Mount battery in a weather tight enclosure on the trailer. See additional instructions supplied with the HPU for mounting, electrical and hydraulic fluid requirements.

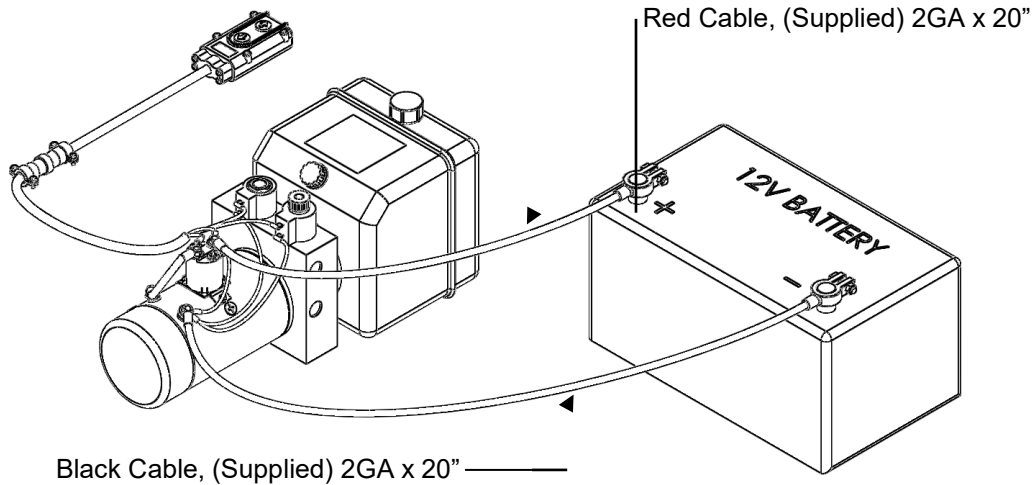

It is highly recommended that the trailer battery be kept charged using one of the Pulsetech products shown on Primary Mover website at <http://www.primarymover.com/>

Troubleshooting

Possible Cause	Problem	Not Building Pressure	Motor Not Running	Cylinder Won' t Extend	Cylinder Won' t Retract	Won' t Hold Load	Excessive Heat From Unit	Aeration of Hyd. Fluid	Reservoir Overflows	Struggles to Lift Load	Load Bounces When Cylinder Retracts	Start Solenoid Just Click-Motor Not Engaging	Won' t Lift Load (DC Motor Under Load)	Won' t Lower	Start Solenoid Stays On	Cylinder Won' t Retract (Motor Under Load)
Low Battery Voltage			o	o	o		o			o		o				
Poor Ground Condition			o	o	o		o			o		o				
Check Hand Control												o		o		o
Debris in Load Holding Valve						o										
Coil Not Energizing				o	o								o	o		o
Bad Seals in Cylinder	o									o						o
Loose Inlet					o			o			o					o
Hoses Connected Backwards										o						
Pump Not Priming	o		o													
Clogged Orifice					o									o		o
Rust in Motor		o														
Check for Additional Valving On or Connected to Cylinder						o										o
Directional Valve Not Shifting Properly				o	o					o				o		o
Bad Start Solenoid												o		o	o	
Dirty Contacts in Hand Control					o							o	o			
Reservoir More Than ½ Full with Cylinder Fully Extended								o								