

HYDRAULIC CYLINDERS

EAGLE 
hydraulic components

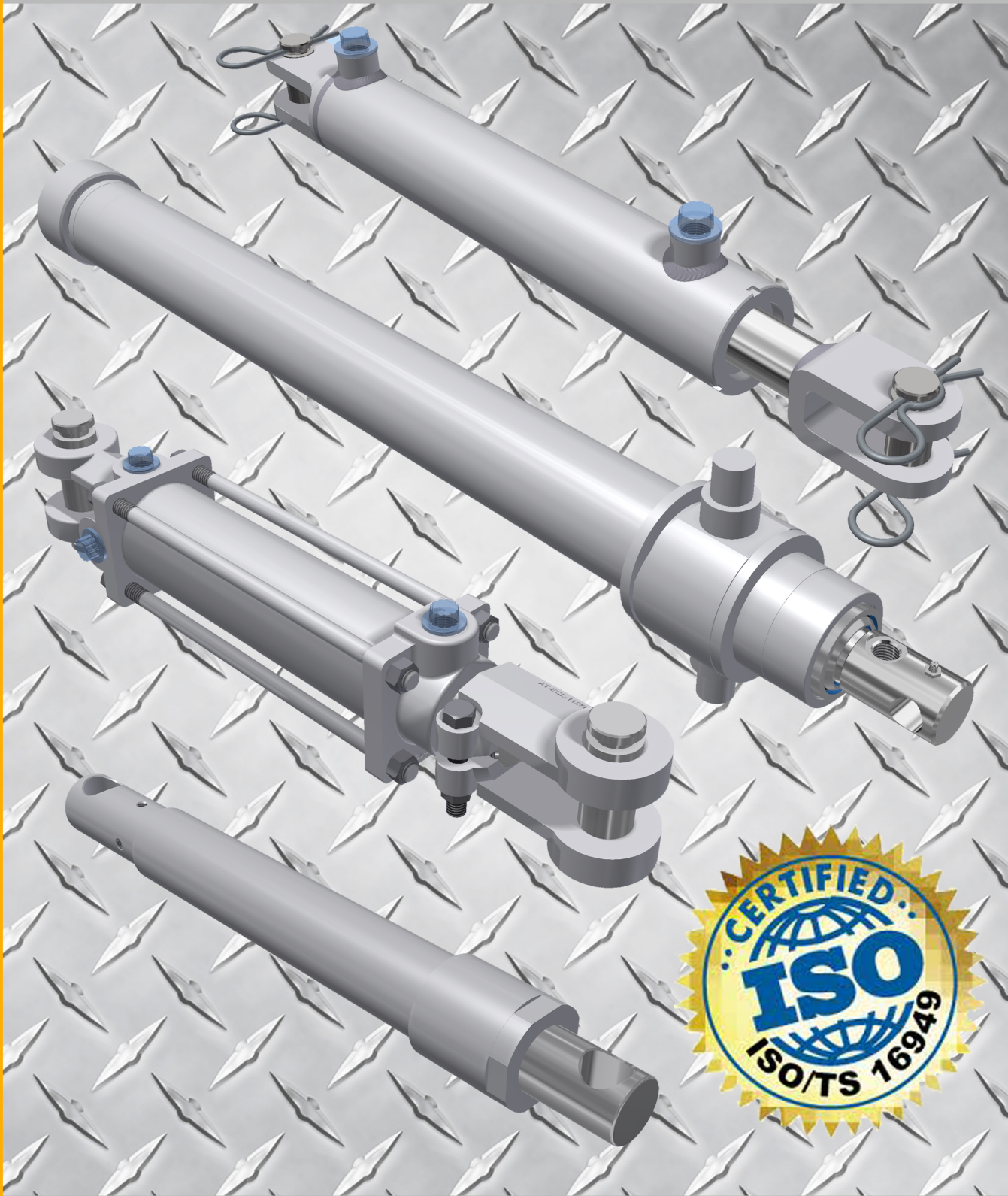

www.eagle-hydraulic.com



TABLE OF CONTENTS

- **HTR Tie-Rod Cylinder 2500 PSI 3**
- **HTH Tie-Rod Cylinder 3000 PSI 7**
- **HCL Welded Cylinder 3000 PSI 11**
- **HBU Welded Cylinder 3000 PSI 14**
- **HTG Welded Cylinder 3000 PSI 17**
- **ORDER INFORMATION 21**
- **HSP Snow Plow Cylinder 2500 PSI 22**
- **HTC Telescopic Cylinder 3000 PSI 23**
- **Customer Cylinders 25**



HTR Tie-Rod Cylinder is double acting Cylinder with:

- ☑ **ROD** - Steel, superior and hard, chrome plated 0.001" thick for a final surface hardness 69-71 Rockwell C;
- ☑ **PISTON** - Ductile Iron, for increased durability;
- ☑ **TUBE** - Steel, Honed and precision finished for extended seal life;
- ☑ **STEEL TIE-ROD** - High tensile strength to prevent stretching;
- ☑ **END CAP** - with 2 ports at 90 degrees to each other for greater flexibility of assembly;
- ☑ **ATTACHMENT** - Ductile Iron, threaded female clevis, adjustable with locking bolt;
- ☑ **PIN** - Steel, zinc plated;
- ☑ **SEALS** - Top quality, manufactured in USA/Europe;
- ☑ **PAINT** - High quality paint for corrosion resistance. [Standard color: Black].

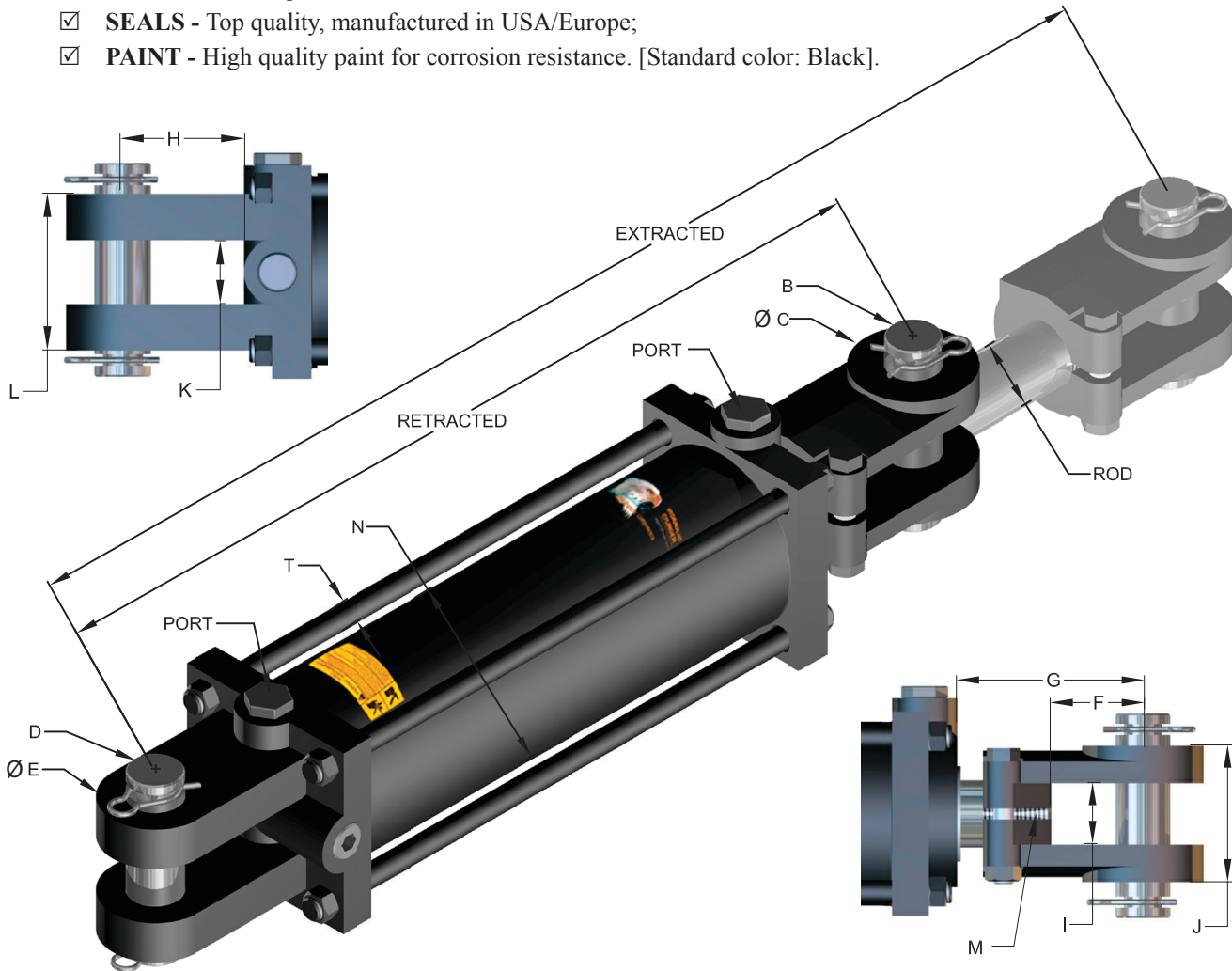

TIE-ROD HYDRAULIC CYLINDERS

EAGLE Part No	BORE	C	E	F	H	I,K	J	L	M	N	T
HTR20-	2.00	2.000	2.000	2.125	2.06	1.125	2.500	2.375	1-1/8-12-UNF	2.375	0.375
HTR25-	2.50	2.000	2.000	2.125	2.06	1.125	2.500	2.500	1-1/8-12-UNF	2.875	0.375
HTR30-	3.00	2.250	2.000	2.125	2.06	1.125	2.625	2.500	1-1/4-12-UNF	3.375	0.500
HTR35-	3.50	2.250	2.250	2.125	2.06	1.125	2.625	2.500	1-1/4-12-UNF	3.875	0.625
HTR40-	4.00	2.250	2.250	2.125	2.06	1.125	2.625	2.625	1-1/4-12-UNF	4.375	0.625
HTR50-	5.00	2.500	3.000	2.125	2.250	1.250	2.875	3.500	1-1/2-12-UNF	5.500	0.810

TIE-ROD HYDRAULIC CYLINDERS

PART No.	STROKE	ROD DIAMETER	DIMENSIONS		G	PORT	PIN D, B	(LBS)	
			RETRACTED	EXTRACTED					
HTR 2" BORE 2500 PSI WP	HTR2004	4"	1 1/8"	14 1/4"	18 1/4"	3.375"	3/8 NPT SAE Available	1"	14
	HTR2006	6"		16 1/4"	22 1/4"				16
	HTR2008	8"		18 1/4"	26 1/4"				17
	HTR2008-ASAE	8"		20 1/4"	28 1/4"	18			
	HTR2010	10"		20 1/4"	30 1/4"	3.375"		19	
	HTR2012	12"		22 1/4"	34 1/4"			20	
	HTR2014	14"		24 1/4"	38 1/4"			22	
	HTR2016	16"		26 1/4"	42 1/4"			24	
	HTR2018	18"		28 1/4"	46 1/4"			26	
	HTR2020	20"		30 1/4"	50 1/4"			27	
	HTR2024	24"		34 1/4"	58 1/4"			30	
	HTR2030	30"		40 1/4"	70 1/4"			35	
	HTR2036	36"		46 1/4"	82 1/4"			40	
	HTR2040	40"		50 1/4"	90 1/4"				
HTR2048	48"	58 1/4"	106 1/4"						
HTR 2.5" BORE 2500 PSI WP	HTR2504	4"	1 1/8"	14 1/4"	18 1/4"	3.375"	3/8 NPT SAE Available	1"	16
	HTR2506	6"		16 1/4"	22 1/4"				18
	HTR2508	8"		18 1/4"	26 1/4"				19
	HTR2508-ASAE	8"		20 1/4"	28 1/4"	20			
	HTR2510	10"		20 1/4"	30 1/4"	3.375"		21	
	HTR2512	12"		22 1/4"	34 1/4"			23	
	HTR2514	14"		24 1/4"	38 1/4"			25	
	HTR2516	16"		26 1/4"	42 1/4"			27	
	HTR2518	18"		28 1/4"	46 1/4"			28	
	HTR2520	20"		30 1/4"	50 1/4"			30	
	HTR2524	24"		34 1/4"	58 1/4"			34	
	HTR2530	30"	1 1/4"	40 1/4"	70 1/4"	45			
	HTR2536	36"		46 1/4"	82 1/4"	56			
	HTR2540	40"		50 1/4"	90 1/4"				
HTR2548	48"	58 1/4"		106 1/4"					

	PART No.	STROKE	ROD DIAMETER	DIMENSIONS		G	PORT	PIN D, B	WEIGHT (LBS)	
				RETRACTED	EXTRACTED					
HTR 3" BORE 2500 PSI WP	HTR3004	4"	1 1/4"	14 1/4"	18 1/4"	3.375"	1/2 NPT	1"	22	
	HTR3006	6"		16 1/4"	22 1/4"				24	
	HTR3008	8"		18 1/4"	26 1/4"				26	
	HTR3008-ASAE	8"		20 1/4"	28 1/4"	5.375"			27	
	HTR3010	10"		20 1/4"	30 1/4"	3.375"			28	
	HTR3012	12"		22 1/4"	34 1/4"				30	
	HTR3014	14"		24 1/4"	38 1/4"				33	
	HTR3016	16"		26 1/4"	42 1/4"				35	
	HTR3016-ASAE	16"	1 1/2"	31 1/2"	47 1/2"	8.625"		SAE Available	1 1/4"	38
	HTR3018	18"	1 1/4"	28 1/4"	46 1/4"	3.375"		1"	37	
	HTR3020	20"	1 1/2"	30 1/4"	50 1/4"				39	
	HTR3024	24"		34 1/4"	58 1/4"				43	
	HTR3030	30"		40 1/4"	70 1/4"				59	
	HTR3036	36"		46 1/4"	82 1/4"				68	
	HTR3040	40"		50 1/4"	90 1/4"					
	HTR3048	48"		58 1/4"	106 1/4"					
HTR 3.5" BORE 2500 PSI WP	HTR3504	4"		1 1/4"	14 1/4"		18 1/4"		3.50"	1/2 NPT
	HTR3506	6"			16 1/4"	22 1/4"	26			
	HTR3508	8"	18 1/4"		26 1/4"	28				
	HTR3508-ASAE	8"	20 1/4"		28 1/4"	5.50"	29			
	HTR3510	10"	20 1/4"		30 1/4"	3.50"	30			
	HTR3512	12"	22 1/4"		34 1/4"		33			
	HTR3514	14"	24 1/4"		38 1/4"		35			
	HTR3516	16"	26 1/4"		42 1/4"		37			
	HTR3516-ASAE	16"	1 1/2"	31 1/2"	47 1/2"	8.80"	SAE Available	1 1/4"	39	
	HTR3518	18"	1 1/4"	28 1/4"	46 1/4"	3.50"	1"	40		
	HTR3520	20"	1 1/2"	30 1/4"	50 1/4"			42		
	HTR3524	24"		34 1/4"	58 1/4"			51		
	HTR3530	30"		40 1/4"	70 1/4"			59		
	HTR3536	36"		46 1/4"	82 1/4"			68		
	HTR3540	40"		50 1/4"	90 1/4"					
	HTR3548	48"		58 1/4"	106 1/4"					

TIE-ROD HYDRAULIC CYLINDERS

TIE-ROD HYDRAULIC CYLINDERS

	PART No.	STROKE	ROD DIAMETER	DIMENSIONS		G	PORT	PIN D, B	WEIGHT (LBS)	
				RETRACTED	EXTRACTED					
HTR 4" BORE 2500 PSI WP	HTR4004	4"	1 1/4"	14 1/4"	18 1/4"	3.375"	1/2 NPT <i>SAE Available</i>	1"	30	
	HTR4006	6"		16 1/4"	22 1/4"				33	
	HTR4008	8"		18 1/4"	26 1/4"				35	
	HTR4008-ASAE	8"		20 1/4"	28 1/4"	36				
	HTR4010	10"		20 1/4"	30 1/4"	3.375"			37	
	HTR4012	12"		22 1/4"	34 1/4"				40	
	HTR4014	14"		24 1/4"	38 1/4"				42	
	HTR4016	16"		26 1/4"	42 1/4"	48				
	HTR4016-ASAE	16"	2"	31 1/2"	47 1/2"	8.625"		1 1/4"	64	
	HTR4018	18"	1 1/4"	28 1/4"	46 1/4"	3.375"		1"	51	
	HTR4020	20"	1 1/2"	30 1/4"	50 1/4"				53	
	HTR4024-150	24"	1 1/2"	34 1/4"	58 1/4"				59	
	HTR4024-175	24"	1 3/4"	34 1/4"	58 1/4"	64				
	HTR4024-200	24"	2"	34 1/4"	58 1/4"	3.375"			1"	70
	HTR4030	30"		40 1/4"	70 1/4"					87
	HTR4036	36"		46 1/4"	82 1/4"					98
	HTR4040	40"		50 1/4"	90 1/4"					
	HTR4048	48"	58 1/4"	106 1/4"						
HTR 5" BORE 1500 PSI WP	HTR5004	4"	1 1/2"	16 1/4"	20 1/4"	3.75"	1/2 NPT <i>SAE Available</i>		1"	53
	HTR5006	6"		18 1/4"	24 1/4"			55		
	HTR5008	8"		20 1/4"	28 1/4"	5.75"		64		
	HTR5008-ASAE	8"		22 1/4"	30 1/4"			66		
	HTR5010	10"	22 1/4"	32 1/4"	3.75"	68				
	HTR5012	12"	24 1/4"	36 1/4"		77				
	HTR5014	14"	26 1/4"	40 1/4"		82				
	HTR5016	16"	28 1/4"	44 1/4"	7.00"	87				
	HTR5016-ASAE	16"	31 1/2"	47 1/2"		90				
	HTR5018	18"	30 1/4"	48 1/4"	3.75"	92				
	HTR5020	20"	32 1/4"	52 1/4"		93				
	HTR5024	24"	36 1/4"	60 1/4"		106				
	HTR5030	30"	42 1/4"	72 1/4"		121				
	HTR5036	36"	48 1/4"	84 1/4"		136				
	HTR5040	40"	52 1/4"	90 1/4"		145				
	HTR5048	48"	60 1/4"	106 1/4"		150				

HTH Tie-Rod Cylinder is double acting Cylinder with:

- ☑ **ROD** - Steel, induction hardened to 45-50 Rockwell C and chrome plated 0.001" thick for a final surface hardness 69-71 Rockwell C. ASTM B117-07a salt spray testing up to 96 hours;
- ☑ **PISTON** - Ductile Iron, for increased durability;
- ☑ **TUBE** - Steel, Honed and precision finished for extended seal life;
- ☑ **STEEL TIE-ROD** - High tensile strength to prevent stretching;
- ☑ **END CAP** - with 2 ORB ports at 90 degrees to each other for greater flexibility of assembly;
- ☑ **ATTACHMENT** - Ductile Iron, threaded female clevis, adjustable with locking bolt;
- ☑ **PIN** - Steel, zinc plated;
- ☑ **SEALS** - Top quality, manufactured in USA/Europe;
- ☑ **PAINT** - High quality paint for corrosion resistance up to 360 hours. [Standard color: Black].

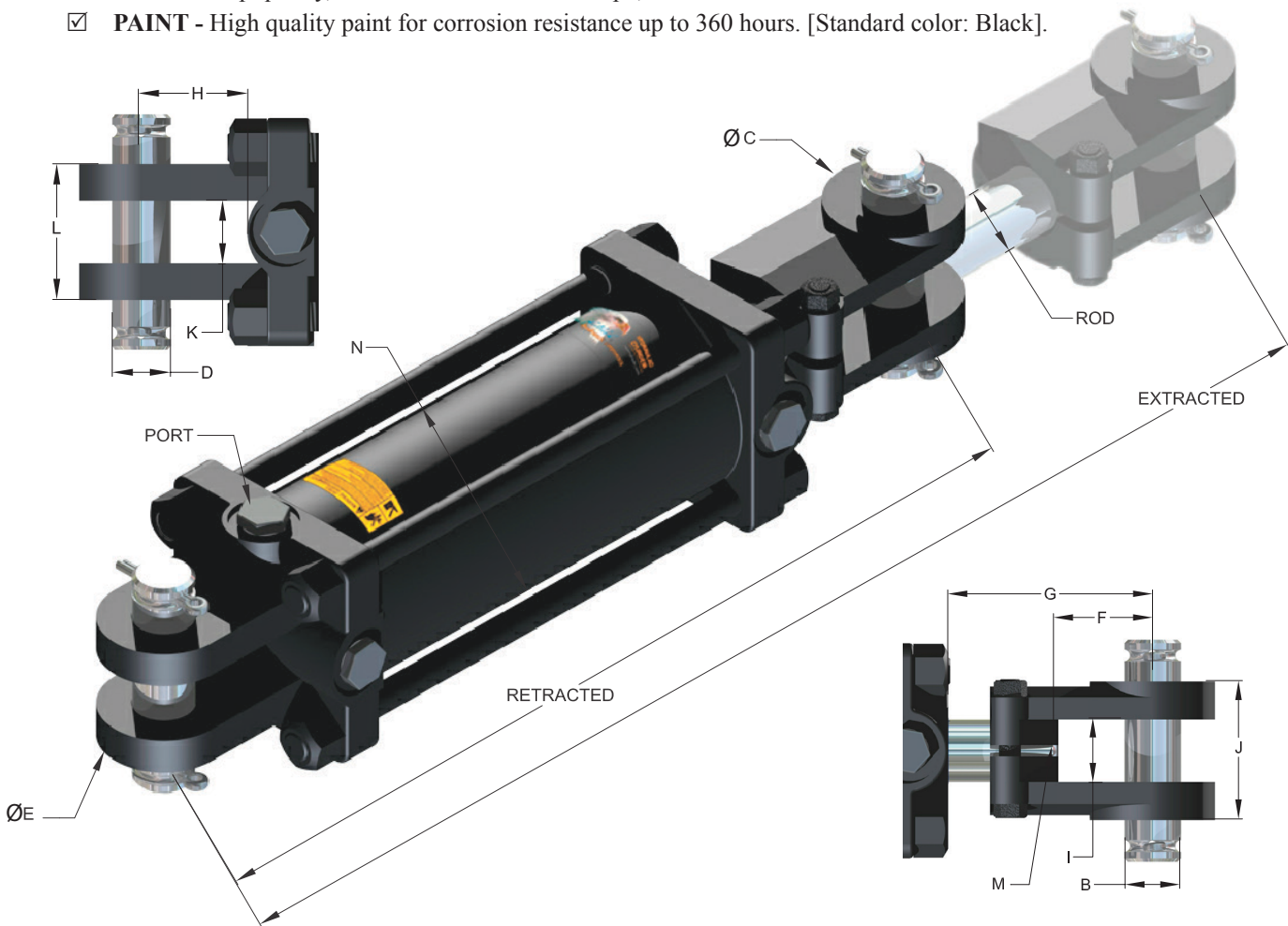

EAGLE Part No	BORE	C	E	F	H	I,K	J	L	M	N
HTH20-	2.00	2.000	2.000	2.125	2.06	1.125	2.500	2.375	1 1/8-12-UNF	2.375
HTH25-	2.50	2.000	2.000	2.125	2.06	1.125	2.500	2.500	1 1/8-12-UNF	2.875
HTH30-	3.00	2.250	2.000	2.125	2.06	1.125	2.625	2.560	1 1/4-12-UNF	3.375
HTH35-	3.50	2.250	2.250	2.125	2.06	1.125	2.625	2.590	1 1/4-12-UNF	3.875
HTH40-	4.00	2.250	2.250	2.125	2.06	1.125	2.625	2.625	1 1/4-12-UNF	4.375
HTH50-	5.00	2.500	3.000	2.125	2.25	1.125	2.2.875	3.5	1 1/2-12-UNF	5.500

TIE-ROD HYDRAULIC CYLINDERS

TIE-ROD HYDRAULIC CYLINDERS

PART No.	STROKE	ROD DIAMETER	DIMENSIONS		G	PORT	PIN (B,D)	WEIGHT (LBS)	
			RETRACTED	EXTRACTED					
HTH 2" BORE - 3000PSI WP	HTH2004	4"	1 1/8"	14 1/4"	18 1/4"	3.375"	SAE #8 [3/4-16UNF] NPT Available	1"	17
	HTH2006	6"		16 1/4"	22 1/4"				19
	HTH2008	8"		18 1/4"	26 1/4"				20
	HTH2008-ASAE	8"		20 1/4"	28 1/4"	5.375"			21
	HTH2010	10"		20 1/4"	30 1/4"	3.375"			22
	HTH2012	12"		22 1/4"	34 1/4"				23
	HTH2014	14"		24 1/4"	38 1/4"				25
	HTH2016	16"		26 1/4"	42 1/4"	26			
	HTH2018	18"		28 1/4"	46 1/4"	28			
	HTH2020	20"		30 1/4"	50 1/4"	29			
	HTH2024	24"		34 1/4"	58 1/4"	32			
	HTH2030	30"		40 1/4"	70 1/4"	36			
	HTH2036	36"		46 1/4"	82 1/4"	41			
	HTH2040	40"		50 1/4"	90 1/4"	45			
HTH2048	48"	58 1/4"	106 1/4"	51					
HTH 2.5" BORE - 3000PSI WP	HTH2504	4"	1 1/4"	14 1/4"	18 1/4"	3.375"	SAE #8 [3/4-16UNF] NPT Available	1"	18
	HTH2506	6"		16 1/4"	22 1/4"				21
	HTH2508	8"		18 1/4"	26 1/4"				23
	HTH2508-ASAE	8"		20 1/4"	28 1/4"	5.375"			24
	HTH2510	10"		20 1/4"	30 1/4"	3.375"			25
	HTH2512	12"		22 1/4"	34 1/4"				26
	HTH2514	14"		24 1/4"	38 1/4"				28
	HTH2516	16"		26 1/4"	42 1/4"	30			
	HTH2518	18"		28 1/4"	46 1/4"	33			
	HTH2520	20"		30 1/4"	50 1/4"	34			
	HTH2524	24"		34 1/4"	58 1/4"	40			
	HTH2530	30"		40 1/4"	70 1/4"	43			
	HTH2536	36"		46 1/4"	82 1/4"	49			
	HTH2540	40"		50 1/4"	90 1/4"	54			
HTH2548	48"	58 1/4"	106 1/4"	60					

PART No.	STROKE	ROD DIAMETER	DIMENSIONS		G	PORT	PIN (B,D)	WEIGHT (LBS)
			RETRACTED	EXTRACTED				
HTH 3" BORE - 3000PSI WP	HTH3004	4"	1 ¼"	14 ¼"	18 ¼"	3.375"	1"	23
	HTH3006	6"		16 ¼"	22 ¼"			26
	HTH3008	8"		18 ¼"	26 ¼"			28
	HTH3008-ASAE	8"		20 ¼"	28 ¼"	3.375"		29
	HTH3010	10"		20 ¼"	30 ¼"	3.375"		30
	HTH3012	12"		22 ¼"	34 ¼"			33
	HTH3014	14"		24 ¼"	38 ¼"			35
	HTH3016	16"	1 ½"	26 ¼"	42 ¼"	8.625"	1 ¼"	38
	HTH3016-ASAE	16"		31 ½"	47 ½"			40
	HTH3018	18"		28 ¼"	46 ¼"	3.375"	1"	40
	HTH3020	20"		30 ¼"	50 ¼"			42
	HTH3024	24"		34 ¼"	58 ¼"			47
	HTH3030	30"		40 ¼"	70 ¼"			54
	HTH3036	36"		46 ¼"	82 ¼"			61
	HTH3040	40"		50 ¼"	90 ¼"			66
HTH3048	48"	58 ¼"	106 ¼"	75				
HTH 3.5" BORE - 3000PSI WP	HTH3504	4"	1 ¼"	14 ¼"	18 ¼"	3.50"	1"	27
	HTH3506	6"		16 ¼"	22 ¼"			30
	HTH3508	8"		18 ¼"	26 ¼"			33
	HTH3508-ASAE	8"		20 ¼"	28 ¼"	5.50"		34
	HTH3510	10"		20 ¼"	30 ¼"	3.50"		36
	HTH3512	12"		22 ¼"	34 ¼"			38
	HTH3514	14"		24 ¼"	38 ¼"			41
	HTH3516	16"	1 ½"	26 ¼"	42 ¼"	8.80"	1 ¼"	44
	HTH3516-ASAE	16"		31 ½"	47 ½"			46
	HTH3518	18"		28 ¼"	46 ¼"	3.50"	1"	47
	HTH3520	20"		30 ¼"	50 ¼"			49
	HTH3524	24"		34 ¼"	58 ¼"			55
	HTH3530	30"		40 ¼"	70 ¼"			63
	HTH3036	36"		46 ¼"	82 ¼"			72
	HTH3040	40"		50 ¼"	90 ¼"			77
HTH3048	48"	58 ¼"	106 ¼"	88				

TIE-ROD HYDRAULIC CYLINDERS

TIE-ROD HYDRAULIC CYLINDERS

PART No.	STROKE	ROD DIAMETER	DIMENSIONS		G	PORT	PIN (B,D)	WEIGHT (LBS)
			RETRACTED	EXTRACTED				
HTH 4" BORE - 3000PSI WP								
HTH4004	4"	1 1/2"	14 1/4"	18 1/4"	3.375"	SAE #8 [3/4-16UNF] NPT Available	1"	34
HTH4006	6"		16 1/4"	22 1/4"				38
HTH4008	8"		18 1/4"	26 1/4"				42
HTH4008-ASAE	8"		20 1/4"	28 1/4"	5.375"			43
HTH4010	10"		20 1/4"	30 1/4"	3.375"			45
HTH4012	12"		22 1/4"	34 1/4"				48
HTH4014	14"		24 1/4"	38 1/4"				52
HTH4016	16"	1 3/4"	26 1/4"	42 1/4"	8.625"		55	
HTH4016-ASAE	16"	2"	31 1/2"	47 1/2"			59	
HTH4018	18"	1 3/4"	28 1/4"	46 1/4"			3.875"	59
HTH4020	20"		30 1/4"	50 1/4"	62			
HTH4024	24"		34 1/4"	58 1/4"	69			
HTH4030	30"	2"	40 1/4"	70 1/4"	3.875"		1"	79
HTH4036	36"		46 1/4"	82 1/4"				90
HTH4040	40"		50 1/4"	90 1/4"		97		
HTH4048	48"		58 1/4"	106 1/4"		110		
HTH 5" BORE - 3000PSI WP								
HTH5004	4"	2"	16 1/4"	20 1/4"	3.75"	SAE #8 [3/4-16UNF] NPT Available	1 1/4"	53
HTH5006	6"		18 1/4"	24 1/4"				55
HTH5008	8"		20 1/4"	28 1/4"				64
HTH5008-ASAE	8"		22 1/4"	30 1/4"	5.75"			66
HTH5010	10"		22 1/4"	32 1/4"	3.75"			68
HTH5012	12"		24 1/4"	36 1/4"				77
HTH5014	14"		26 1/4"	40 1/4"				82
HTH5016	16"		28 1/4"	44 1/4"	7.00"			87
HTH5016-ASAE	16"		31 1/2"	47 1/2"				90
HTH5018	18"		30 1/4"	48 1/4"				3.75"
HTH5020	20"		32 1/4"	52 1/4"	93			
HTH5024	24"		36 1/4"	60 1/4"	106			
HTH5030	30"		42 1/4"	72 1/4"	3.75"			121
HTH5036	36"		48 1/4"	84 1/4"				
HTH5040	40"		52 1/4"	92 1/4"				
HTH5048	48"		60 1/4"	108 1/4"				136

HCL Cylinder is double acting Cylinder with:

- ☑ **ROD** - Steel, induction hardened to 45-50 Rockwell C and chrome plated 0.001” thick for a final surface hardness 69-71 Rockwell C. ASTM B117-07a salt spray testing 96 hours.
- ☑ **PISTON** - Ductile Iron, for increased durability.
- ☑ **TUBE** - Steel, Honed and precision finished.
- ☑ **CONSTRUCTION** -heavy duty welded construction.
- ☑ **GLAND** - Threaded.
- ☑ **PIN** - Steel, zinc plated.
- ☑ **SEALS** - Top quality, manufactured in USA/Europe.

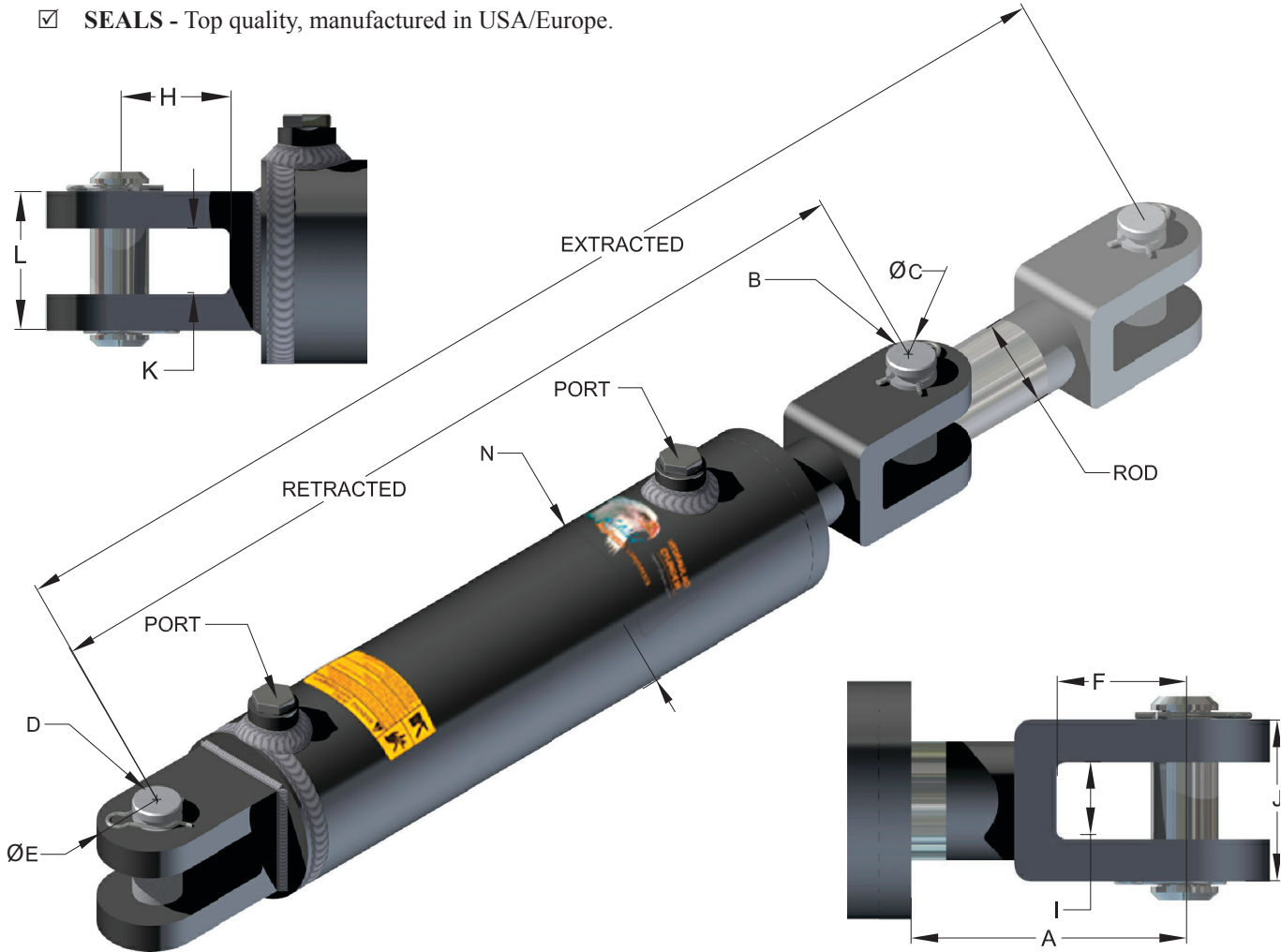

EAGLE Part No	BORE	A	C	E	F	H	I,K	J	L	N
HCL20-	2.00	3.20 / 5.20 for HCL2008	2.00	2.00	2.125	2.125	1.125	2.125	2.125	2.375
HCL25-	2.50	3.0 / 5.0 for HCL2508	2.00	2.00	2.125	2.125	1.125	2.125	2.125	2.875
HCL30-	3.00	3.10 / 5.10 for HCL3008	2.00[2.25]	2.00	2.125	1.972	1.125	2.125	2.125	3.500
HCL35-	3.50	3.25 / 5.25 for HCL3508	2.00	2.00	2.125	1.972[2.125]	1.125	2.385	2.385	4.000
HCL40-	4.00	3.0 / 5.0 for HCL4008	3.00[2.25]	3.00 [2.00]	2.000	1.843[2.00]	1.125	2.385	2.385	4.500
HCL50-	5.00	3.8	3.00[2.50]	3.00 [2.00]	2.000	1.913[2.00]	1.500	2.750	2.750	5.500

UTILITY WELDED HYDRAULIC CYLINDERS

UTILITY WELDED HYDRAULIC CYLINDERS

PART No.	STROKE	ROD DIAMETER	DIMENSIONS		PORT	PIN	WEIGHT (LBS)
			RETRACTED	EXTRACTED			
HCL 2" BORE 3000 PSI WP							
HCL2004	4"	1 1/4"	14 1/4"	18 1/4"	SAE#6	1"	14
HCL2006	6"		16 1/4"	22 1/4"			15
HCL2008	8"		20 1/4"	28 1/4"			17
HCL2010	10"		20 1/4"	30 1/4"			17
HCL2012	12"		22 1/4"	34 1/4"			19
HCL2014	14"		24 1/4"	38 1/4"			21
HCL2016	16"		26 1/4"	42 1/4"			23
HCL2018	18"		28 1/4"	46 1/4"			24
HCL2020	20"		30 1/4"	50 1/4"			26
HCL2024	24"		34 1/4"	58 1/4"			28
HCL2028	28"		38 1/4"	66 1/4"			34
HCL2030	30"		40 1/4"	70 1/4"			35
HCL2032	32"		42 1/4"	74 1/4"			36
HCL2034	34"		44 1/4"	78 1/4"			39
HCL2036	36"		46 1/4"	82 1/4"			40
HCL 2.5" BORE 3000 PSI WP							
HCL2504	4"	1 1/2"	14 1/4"	18 1/4"	SAE#8	1"	17
HCL2506	6"		16 1/4"	22 1/4"			20
HCL2508	8"		20 1/4"	28 1/4"			22
HCL2510	10"		20 1/4"	30 1/4"			23
HCL2512	12"		22 1/4"	34 1/4"			25
HCL2514	14"		24 1/4"	38 1/4"			28
HCL2516	16"		26 1/4"	42 1/4"			30
HCL2518	18"		28 1/4"	46 1/4"			31
HCL2520	20"		30 1/4"	50 1/4"			34
HCL2524	24"		34 1/4"	58 1/4"			38
HCL2528	28"		38 1/4"	66 1/4"			42
HCL2530	30"		40 1/4"	70 1/4"			45
HCL2532	32"		42 1/4"	74 1/4"			46
HCL2534	34"		44 1/4"	78 1/4"			50
HCL2536	36"		46 1/4"	82 1/4"			51
HCL 3" BORE 3000 PSI WP							
HCL3004	4"	1 1/2"	14 1/4"	18 1/4"	SAE#8	1"	23
HCL3006	6"		16 1/4"	22 1/4"			26
HCL3008	8"		20 1/4"	28 1/4"			28
HCL3010	10"		20 1/4"	30 1/4"			29
HCL3012	12"		22 1/4"	34 1/4"			30
HCL3014	14"		24 1/4"	38 1/4"			32
HCL3016	16"		26 1/4"	42 1/4"			36
HCL3018	18"		28 1/4"	46 1/4"			39
HCL3020	20"		30 1/4"	50 1/4"			42
HCL3024	24"		34 1/4"	58 1/4"			46
HCL3028	28"		38 1/4"	66 1/4"			51
HCL3030	30"		40 1/4"	70 1/4"			54
HCL3032	32"		42 1/4"	74 1/4"			56
HCL3034	34"		44 1/4"	78 1/4"			59
HCL3036	36"		46 1/4"	82 1/4"			61

NPT PORTS AVAILABLE

PART No.	STROKE	ROD DIAMETER	DIMENSIONS		PORT	PIN	WEIGHT (LBS)	
			RETRACTED	EXTRACTED				
HCL 3.5" BORE 3000 PSI WP	HCL3504	4"	1 3/4"	14 1/4"	18 1/4"	SAE#8	1" <i>1 1/4" Available</i>	26
	HCL3506	6"		16 1/4"	22 1/4"			29
	HCL3508	8"		20 1/4"	28 1/4"			33
	HCL3510	10"		20 1/4"	30 1/4"			36
	HCL3512	12"		22 1/4"	34 1/4"			39
	HCL3514	14"		24 1/4"	38 1/4"			41
	HCL3516	16"		26 1/4"	42 1/4"			45
	HCL3518	18"		28 1/4"	46 1/4"			48
	HCL3520	20"		30 1/4"	50 1/4"			52
	HCL3524	24"		34 1/4"	58 1/4"			55
	HCL3528	28"		38 1/4"	66 1/4"			62
	HCL3530	30"		40 1/4"	70 1/4"			66
	HCL3532	32"		42 1/4"	74 1/4"			70
	HCL3534	34"		44 1/4"	78 1/4"			73
	HCL3536	36"		46 1/4"	82 1/4"			77
HCL 4" BORE 3000 PSI WP	HCL4004	4"	2"	14 1/4"	18 1/4"	SAE#8	1" <i>1 1/2" Available</i>	31
	HCL4006	6"		16 1/4"	22 1/4"			36
	HCL4008	8"		20 1/4"	28 1/4"			41
	HCL4010	10"		20 1/4"	30 1/4"			46
	HCL4012	12"		22 1/4"	34 1/4"			47
	HCL4014	14"		24 1/4"	38 1/4"			50
	HCL4016	16"		26 1/4"	42 1/4"			53
	HCL4018	18"		28 1/4"	46 1/4"			56
	HCL4020	20"		30 1/4"	50 1/4"			61
	HCL4024	24"		34 1/4"	58 1/4"			66
	HCL4028	28"		38 1/4"	66 1/4"			77
	HCL4030	30"		40 1/4"	70 1/4"			81
	HCL4032	32"		42 1/4"	74 1/4"			87
	HCL4034	34"		44 1/4"	78 1/4"			90
	HCL4036	36"		46 1/4"	82 1/4"			94
HCL 5" BORE 3000 PSI WP	HCL5004	4"	2 1/2"	16 1/4"	20 1/4"	SAE#8 SAE#12	1" <i>1 1/2" Available</i>	63
	HCL5006	6"		18 1/4"	24 1/4"			67
	HCL5008	8"		20 1/4"	28 1/4"			71
	HCL5010	10"		22 1/4"	32 1/4"			76
	HCL5012	12"		24 1/4"	36 1/4"			80
	HCL5014	14"		26 1/4"	40 1/4"			84
	HCL5016	16"		28 1/4"	44 1/4"			89
	HCL5018	18"		30 1/4"	48 1/4"			93
	HCL5020	20"		32 1/4"	52 1/4"			98
	HCL5024	24"		36 1/4"	60 1/4"			106
	HCL5028	28"		40 1/4"	68 1/4"			115
	HCL5030	30"		42 1/4"	72 1/4"			120
	HCL5032	32"		44 1/4"	76 1/4"			124
	HCL5034	34"		46 1/4"	80 1/4"			129
	HCL5036	36"		48 1/4"	84 1/4"			133

UTILITY WELDED HYDRAULIC CYLINDERS

NPT PORTS AVAILABLE

HBU Cylinder is double acting Cylinder with:

- ☑ **ROD** - Steel, induction hardened to 45-50 Rockwell C and chrome plated 0.001” thick for a final surface hardness 69-71 Rockwell C. ASTM B117-07a salt spray testing 96 hours.
- ☑ **PISTON** - Ductile Iron, for increased durability.
- ☑ **TUBE** - Steel, Honed and precision finished.
- ☑ **CONSTRUCTION** -heavy duty welded construction.
- ☑ **GLAND** - Threaded.
- ☑ **PIN** - Steel, zinc plated.
- ☑ **SEALS**- Top quality, manufactured in USA/Europe.

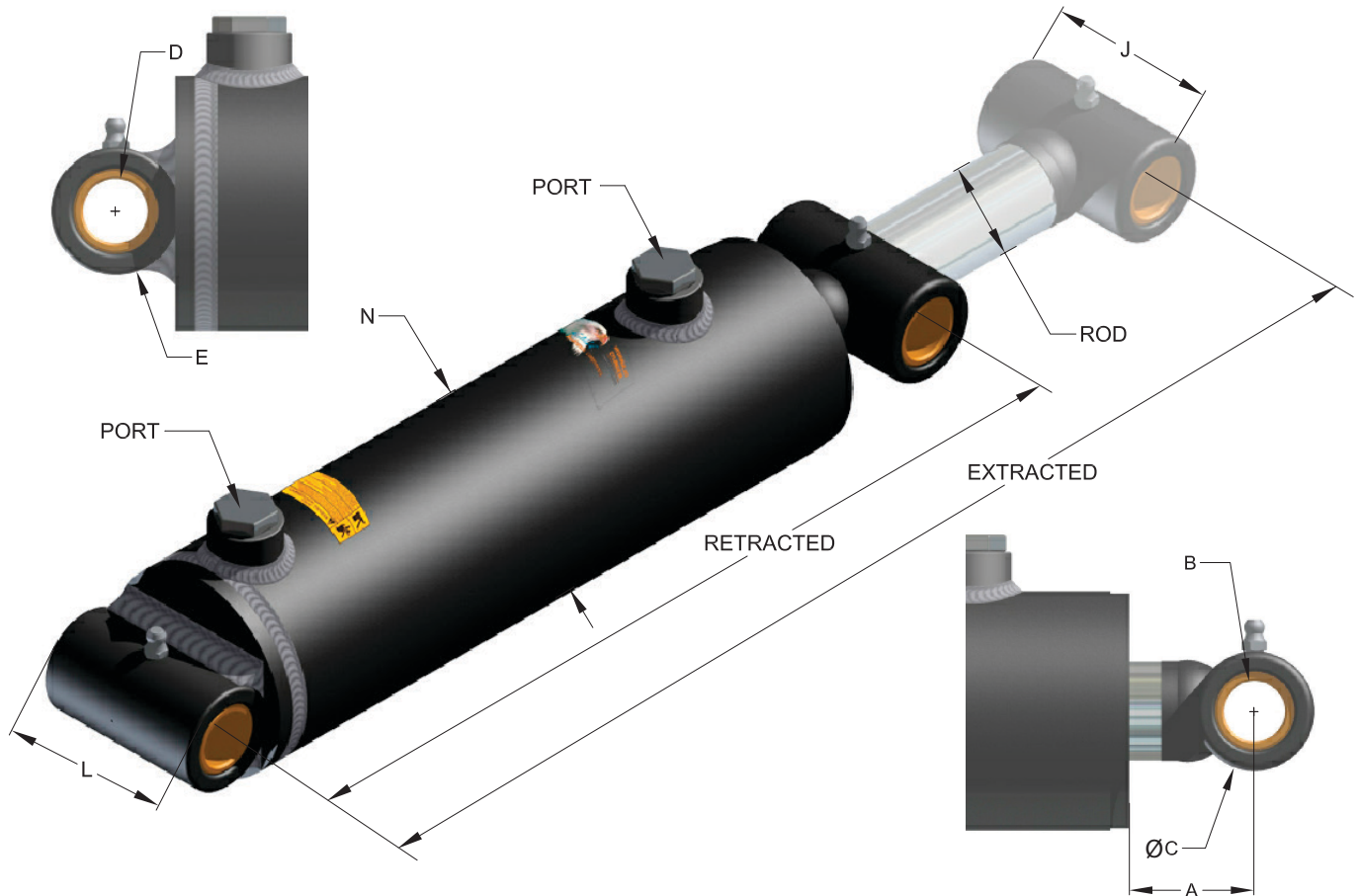

EAGLE Part No	BORE	ROD	A	C, E	B, D	J	L	N
HBU15-	1.50	1.00	2.70	1.250	0.750	2.00	2.25	1,875
HBU20-	2.00	1.25	2.80	1.500	1.00	2.25	2.75	2,375
HBU25-	2.50	1.50	2.65	1.500	1.000	2.25	3.25	2,875
HBU30-	3.00	1.50	2.20	1.500	1.000	2.25	3.75	3.50
HBU35-	3.50	1.75	4.10	2.000	1.250	2.25	4.25	4.00
HBU40-	4.00	2.00	3.60	2.250	1.500	2.50	4.75	4,500
HBU50-	5.00	2.50	4.50	2.500	1.750	3.25	5.75	5,500

BORE	PART No.	STROKE	ROD DIAMETER	DIMENSIONS		PORT	PIN	WEIGHT (LBS)
				RETRACTED	EXTRACTED			
1.5" BORE 3000 PSI WP	HBU1504	4"	1"	12"	16"	SAE#4	3/4"	9
	HBU1506	6"		14"	20"			10
	HBU1508	8"		16"	24"			11
	HBU1510	10"		18"	28"			13
	HBU1512	12"		20"	32"			14
	HBU1514	14"		22"	36"			15
	HBU1516	16"		24"	40"			17
2" BORE 3000PSI WP	HBU2004	4"	1 1/4"	12"	16"	SAE#6	1"	13
	HBU2006	6"		14"	20"			14
	HBU2008	8"		16"	24"			15
	HBU2010	10"		18"	28"			15
	HBU2012	12"		20"	32"			16
	HBU2014	14"		22"	36"			17
	HBU2016	16"		24"	40"			22
	HBU2018	18"		26"	44"			22
	HBU2020	20"		28"	48"			23
	HBU2024	24"		32"	56"			28
	HBU2028	28"		36"	64"			31
	HBU2030	30"		38"	68"			34
	HBU2032	32"		40"	72"			36
	HBU2036	36"		44"	80"			39
	HBU2040	40"		48"	88"			40
HBU2048	48"	56"	104"	50				
2.5" BORE 3000PSI WP	HBU2504	4"	1 1/2"	12"	16"	SAE#8	1"	17
	HBU2506	6"		14"	20"			18
	HBU2508	8"		16"	24"			19
	HBU2510	10"		18"	28"			22
	HBU2512	12"		20"	32"			24
	HBU2514	14"		22"	36"			26
	HBU2516	16"		24"	40"			30
	HBU2518	18"		26"	44"			31
	HBU2520	20"		28"	48"			32
	HBU2524	24"		32"	56"			37
	HBU2528	28"		36"	64"			42
	HBU2530	30"		38"	68"			44
	HBU2532	32"		40"	72"			46
	HBU2536	36"		44"	80"			50
	HBU2540	40"		48"	88"			55
HBU2548	48"	56"	104"	62				

UTILITY WELDED HYDRAULIC CYLINDERS

UTILITY WELDED HYDRAULIC CYLINDERS

	PART No.	STROKE	ROD DIAMETER	DIMENSIONS		PORT	PIN	WEIGHT (LBS)
				RETRACTED	EXTRACTED			
HBU 3" BORE 3000PSI WP	HBU3004	4"	1 1/2"	12"	16"	SAE#8	1"	24
	HBU3006	6"		14"	20"			25
	HBU3008	8"		16"	26"			26
	HBU3010	10"		18"	30"			28
	HBU3012	12"		20"	34"			29
	HBU3014	14"		22"	38"			31
	HBU3016	16"		24"	42"			32
	HBU3018	18"		26"	44"			36
	HBU3020	20"		28"	48"			39
	HBU3024	24"		32"	56"			42
	HBU3028	28"		25"	64"			48
	HBU3030	30"		38"	68"			52
	HBU3032	32"		40"	72"			56
	HBU3036	36"		44"	80"			60
	HBU3040	40"		48"	88"			65
HBU3048	48"	56"	104"	71				
HBU 3.5" BORE 3000PSI WP	HBU3504	4"	1 3/4"	12"	16"	SAE#8	1 1/4"	28
	HBU3506	6"		14"	20"			31
	HBU3508	8"		18"	26"			33
	HBU3510	10"		20"	30"			36
	HBU3512	12"		22"	34"			39
	HBU3514	14"		24"	38"			41
	HBU3516	16"		26"	42"			45
	HBU3518	18"		28"	46"			48
	HBU3520	20"		30"	50"			51
	HBU3524	24"		34"	58"			56
	HBU3528	28"		38"	66"			60
	HBU3530	30"		40"	70"			64
	HBU3532	32"		42"	74"			68
	HBU3536	36"		46"	82"			77
	HBU3540	40"		50"	90"			81
HBU3548	48"	58"	106"	85				

NPT PORTS AVAILABLE

PART No.	STROKE	ROD DIAMETER	DIMENSIONS		PORT	PIN	WEIGHT (LBS)	
			RETRACTED	EXTRACTED				
HBU 4" BORE 3000PSI WP	HBU4004	4"	2"	12"	16"	SAE#8	1 1/2"	35
	HBU4006	6"		14"	20"			38
	HBU4008	8"		18"	26"			41
	HBU4010	10"		20"	30"			45
	HBU4012	12"		22"	34"			48
	HBU4014	14"		24"	38"			52
	HBU4016	16"		26"	42"			55
	HBU4018	18"		28"	46"			59
	HBU4020	20"		30"	50"			63
	HBU4024	24"		34"	58"			68
	HBU4028	28"		38"	66"			77
	HBU4030	30"		40"	70"			81
	HBU4032	32"		42"	74"			84
	HBU4036	36"		46"	82"			92
	HBU4040	40"		50"	90"			99
HBU4048	48"	58"	106"	114				
HBU 5" BORE 3000PSI WP	HBU5004	4"	2 1/2"	12"	16"	SAE#12 /SAE#8	1 3/4"	63
	HBU5006	6"		14"	20"			67
	HBU5008	8"		20"	28"			71
	HBU5010	10"		22"	32"			76
	HBU5012	12"		24"	36"			80
	HBU5014	14"		26"	40"			81
	HBU5016	16"		28"	44"			89
	HBU5018	18"		30"	48"			93
	HBU5020	20"		32"	52"			98
	HBU5024	24"		36"	60"			106
	HBU5028	28"		40"	68"			115
	HBU5030	30"		42"	72"			120
	HBU5032	32"		44"	76"			124
	HBU5036	36"		48"	84"			133
	HBU5040	40"		52"	92"			142
HBU5048	48"	60"	108"	159				

UTILITY WELDED HYDRAULIC CYLINDERS

HTG Cylinder is double acting Cylinder with:

- ☑ **ROD** - Steel, induction hardened to 45-50 Rockwell C and chrome plated 0.001” thick for a final surface hardness 69-71 Rockwell C. ASTM B117-07a salt spray testing 96 hours.
- ☑ **PISTON** - Ductile Iron, for increased durability.
- ☑ **TUBE** - Steel, Honed and precision finished.
- ☑ **CONSTRUCTION** -heavy duty welded construction.
- ☑ **ROD END** - Ductile Iron, threaded female clevis, adjustable with locking bolt.
- ☑ **GLAND** - Threaded.
- ☑ **SEALS** - Top quality, manufactured in USA/Europe.

WELDED HYDRAULIC CYLINDERS

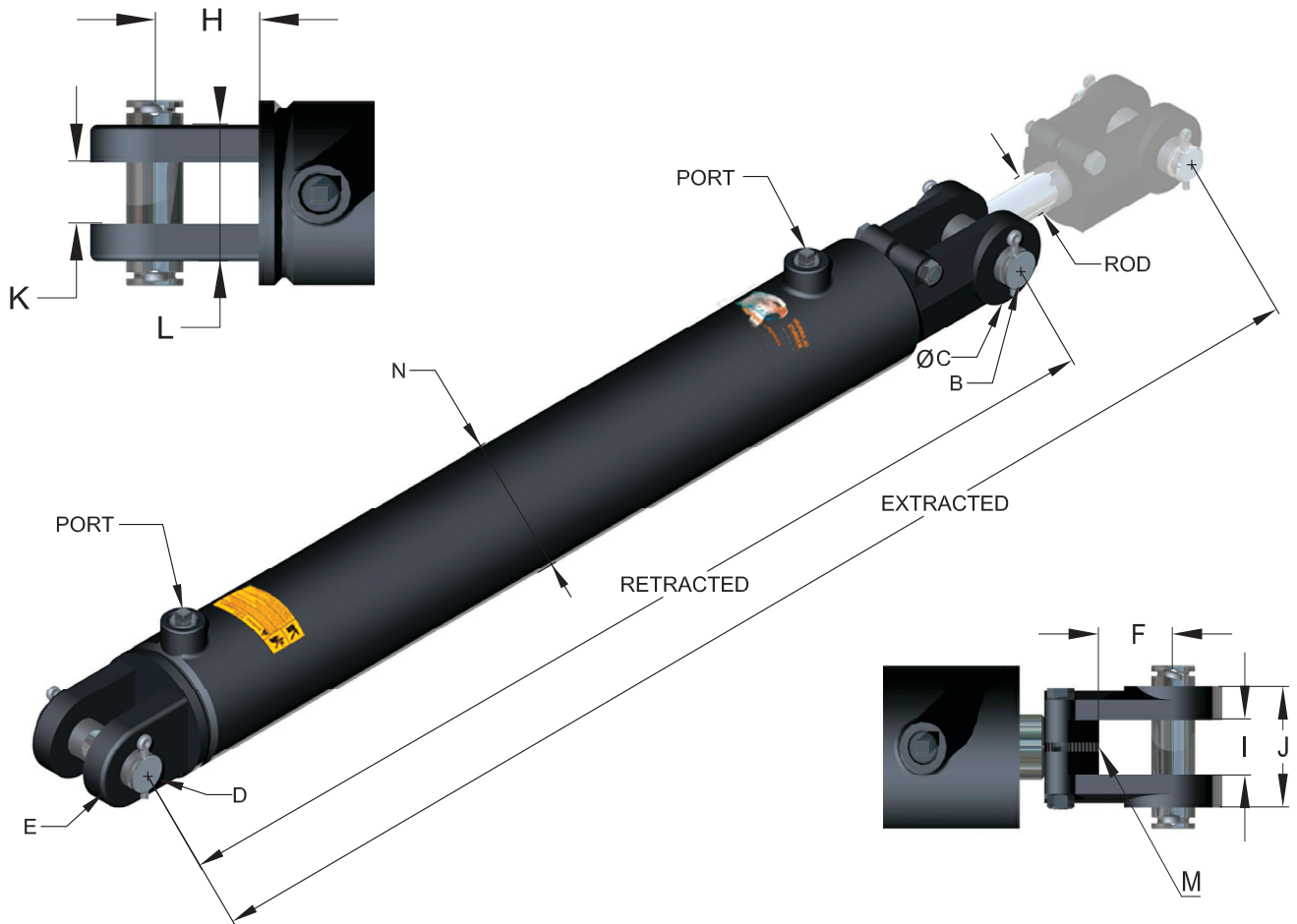

EAGLE Part No	BORE	ROD	C	E	B, D	F	H	I	K	J	L	M	N	PORTS
HTG20-	2.00	1.125	2.00[2.25]	2.087[2.0]	1.000	2.125[1.937]	1.750	1.125[1.063]	1.125	2.500	2.125	1 1/8-12-UN	2.375	SAE #6
HTG25-	2.50	1.250	2.00[2.25]	2.000	1.000	2.125[1.937]	1.750	1.125[1.063]	1.125	2.500	2.500	1 1/8-12-UN	2.875	SAE #8
HTG30-	3.00	1.375	2.250	2.250	1.000	2.125	1.750	1.125[1.063]	1.125	2.625	2.500	1 1/4-12-UN	3.375	SAE #8
HTG35-	3.50	1.500	2.500	2.500	1.000	2.125[1.875]	1.750	1.125[1.063]	1.125	2.625	2.750	1 1/4-12-UN	3.875	SAE #8
HTG40-	4.00	1.750	2.500	2.500	1.000	2.125[1.875]	1.750	1.125[1.063]	1.125	2.625	2.750	1 1/2-12-UN	4.375	SAE #8

PART No.	STROKE	ROD DIAMETER	DIMENSIONS		PORT	PIN (B,D)	WEIGHT (LBS)	
			RETRACTED	EXTRACTED				
HTG 2" BORE 3000PSI WP	HTG2004	4"	1 1/8"	14 1/4"	18 1/4"	SAE #6 1/2 NPT Available	1"	16
	HTG2006	6"		16 1/4"	22 1/4"			17
	HTG2008	8"		18 1/4"	26 1/4"			18
	HTG2008-ASAE	8"		20 1/4"	28 1/4"			19
	HTG2010	10"		20 1/4"	30 1/4"			20
	HTG2012	12"		22 1/4"	34 1/4"			22
	HTG2014	14"		24 1/4"	38 1/4"			23
	HTG2016	16"		26 1/4"	42 1/4"			25
	HTG2018	18"		28 1/4"	46 1/4"			26
	HTG2020	20"		30 1/4"	50 1/4"			28
	HTG2024	24"		34 1/4"	58 1/4"			31
	HTG2028	28"		38 1/4"	66 1/4"			37
	HTG2030	30"		40 1/4"	70 1/4"			39
	HTG2032	32"		42 1/4"	74 1/4"			41
	HTG2034	34"		44 1/4"	78 1/4"			43
HTG2036	36"	46 1/4"	82 1/4"	45				
HTG 2.5" BORE 3000PSI WP	HTG2504	4"	1 1/4"	14 1/4"	18 1/4"	SAE #8 1/2 NPT Available	1"	17
	HTG2506	6"		16 1/4"	22 1/4"			18
	HTG2508	8"		18 1/4"	26 1/4"			20
	HTG2508-ASAE	8"		20 1/4"	28 1/4"			21
	HTG2510	10"		20 1/4"	30 1/4"			22
	HTG2512	12"		22 1/4"	34 1/4"			23
	HTG2514	14"		24 1/4"	38 1/4"			25
	HTG2516	16"		26 1/4"	42 1/4"			27
	HTG2518	18"		28 1/4"	46 1/4"			29
	HTG2520	20"		30 1/4"	50 1/4"			31
	HTG2524	24"		34 1/4"	58 1/4"			35
	HTG2528	28"		38 1/4"	66 1/4"			37
	HTG2530	30"		40 1/4"	70 1/4"			41
	HTG2532	32"		42 1/4"	74 1/4"			43
	HTG2534	34"		44 1/4"	78 1/4"			45
HTG2536	36"	46 1/4"	82 1/4"	47				

WELDED HYDRAULIC CYLINDERS

WELDED HYDRAULIC CYLINDERS

PART No.	STROKE	ROD DIAMETER	DIMENSIONS		PORT	PIN (B,D)	WEIGHT (LBS)
			RETRACTED	EXTRACTED			
HTG 3" BORE 3000PSI WP							
HTG3004	4"	1 3/8"	14 1/4"	18 1/4"	SAE #8 1/2 NPT <i>Available</i>	1"	18
HTG3006	6"		16 1/4"	22 1/4"			20
HTG3008	8"		18 1/4"	26 1/4"			22
HTG3008-ASAE	8"		20 1/4"	28 1/4"			23
HTG3010	10"		20 1/4"	30 1/4"			26
HTG3012	12"		22 1/4"	34 1/4"			28
HTG3014	14"		24 1/4"	38 1/4"			31
HTG3016	16"		26 1/4"	42 1/4"			33
HTG3018	18"		28 1/4"	46 1/4"			35
HTG3020	20"		30 1/4"	50 1/4"			39
HTG3024	24"		34 1/4"	58 1/4"			43
HTG3028	28"		38 1/4"	66 1/4"			46
HTG3030	30"		40 1/4"	70 1/4"			49
HTG3032	32"		42 1/4"	74 1/4"			50
HTG3034	34"		44 1/4"	78 1/4"			53
HTG3036	36"	46 1/4"	82 1/4"	54			
HTG 3.5" BORE 3000PSI WP							
HTG3504	4"	1 1/2"	14 1/4"	18 1/4"	SAE #8 1/2 NPT <i>Available</i>	1"	25
HTG3506	6"		16 1/4"	22 1/4"			27
HTG3508	8"		18 1/4"	26 1/4"			28
HTG3508-ASAE	8"		20 1/4"	28 1/4"			29
HTG3510	10"		20 1/4"	30 1/4"			31
HTG3512	12"		22 1/4"	34 1/4"			33
HTG3514	14"		24 1/4"	38 1/4"			35
HTG3516	16"		26 1/4"	42 1/4"			36
HTG3518	18"		28 1/4"	46 1/4"			38
HTG3520	20"		30 1/4"	50 1/4"			43
HTG3524	24"		34 1/4"	58 1/4"			48
HTG3528	28"		38 1/4"	66 1/4"			52
HTG3530	30"		40 1/4"	70 1/4"			54
HTG3532	32"		42 1/4"	74 1/4"			56
HTG3534	34"		44 1/4"	78 1/4"			58
HTG3536	36"	46 1/4"	82 1/4"	60			

PART No.	STROKE	ROD DIAMETER	DIMENSIONS		PORT	PIN (B,D)	WEIGHT (LBS)
			RETRACTED	EXTRACTED			
HTG4004	4"	1 3/4"	14 1/4"	18 1/4"	SAE #8 1/2 NPT Available	1"	35
HTG4006	6"		16 1/4"	22 1/4"			37
HTG4008	8"		18 1/4"	26 1/4"			38
HTG4008-ASAE	8"		20 1/4"	28 1/4"			40
HTG4010	10"		20 1/4"	30 1/4"			43
HTG4012	12"		22 1/4"	34 1/4"			45
HTG4014	14"		24 1/4"	38 1/4"			48
HTG4016	16"		26 1/4"	42 1/4"			54
HTG4018	18"		28 1/4"	46 1/4"			56
HTG4020	20"		30 1/4"	50 1/4"			58
HTG4024	24"		34 1/4"	58 1/4"			60
HTG4028	28"		38 1/4"	66 1/4"			63
HTG4030	30"		40 1/4"	70 1/4"			65
HTG4032	32"		42 1/4"	74 1/4"			68
HTG4034	34"		44 1/4"	78 1/4"			72
HTG4036	36"	46 1/4"	82 1/4"	74			

HTG 4" BORE
3000PSI WP

WELDED HYDRAULIC CYLINDERS

ORDER INFORMATION (if different then our Standard)

	HTH	20	04	-	1250	-	ASAE	-	ORB	R...	-	P	-	00	
	1	2	3		4		5		6	7		8		9	
1. MODEL															10. DESIGN SERIES
HTR- pages 3-6															omit- Factory Specified
HTH- pages 7-10															
HCL- pages 11-13															8. PAINT
HBU- pages 14-16															omit- Standard Paint Black
HTG- pages 17-20															*- Customer's color code
															CPG (presents grey primer);
															CPR (presents red primer);
															CWT (presents White color)
2. BORE															7. POSITION OF PORTS
15- 1.5"															omit- Standard position
20- 2.0"															R- 90°
25- 2.5"															
35- 3.5"															6. PORT TYPE
40- 4.0"															omit- Ports type NPT
50- 5.0"															ORB - SAE O-Ring
...															
3. STROKE															5. EXTENDED ROD
04- 4"															omit- Not available
06- 6"															ASAE- Extended with 2"
08- 8"															
10- 10"															
12- 12"															
...48- 48"															
4. ROD															
1000- Ø1.000"															
1125- Ø1.125"															
1250- Ø1.250"															
1500- Ø1.500"															
...															

SPECIAL FEATURES

All pictures may differ from the final products. Product specifications are subject to changes without notice.

HSP Cylinder is single acting Cylinder with:

- ☑ **Hi shock applications;**
- ☑ **Welded construction;**
- ☑ **GLAND** - Threaded, Ductile iron;
- ☑ **SEALS** - Top quality, manufactured in USA/Europe;

Custom and double acting cylinders available on request.
NITRIDE ROD available

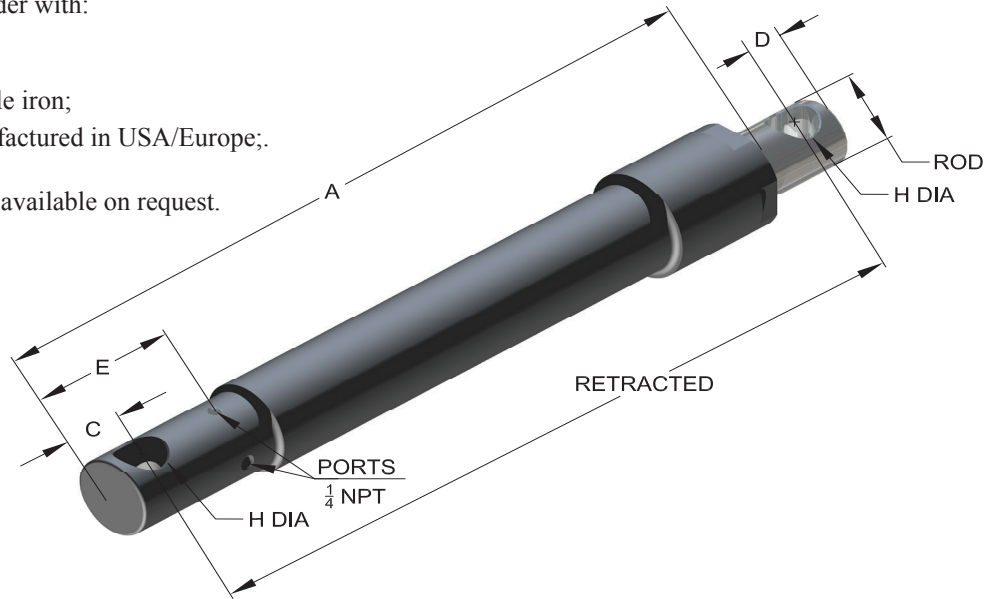

PART No.	BORE	STROKE	PIN DIA (H)	ROD	A	B	C(D)	E
HASP-1510-0750	1 3/4"	10"	3/4"	1 1/2"	16 5/8"	17"	3/4"	2 3/4"
HASP-1512-0750	1 3/4"	12"	3/4"	1 1/2"	16 5/8"	19"	3/4"	2 3/4"
HFSP-1510-1000	1 3/4"	10"	1"	1 1/2"	16 3/8"	17 1/4"	3/4"	2 5/8"
HFSP-1512-1000	1 3/4"	12"	1"	1 1/2"	18 7/6"	19 1/4"	3/4"	2 5/8"
HFSP-2016-1250	2 1/4"	16"	1 1/4"	2"	22 1/2"	23 1/4"	7/8"	2 3/4"
HMSP-1506-0625	1 3/4"	6"	5/8"	1 1/8"	11 7/8"	12 3/8"	3/4"	2 1/8"
HMSP-1510-0625	1 3/4"	10"	5/8"	1 1/2"	15 7/8"	16 3/16"	3/4"	2 1/8"
HMSP-1512-0625	1 3/4"	12"	5/8"	1 1/2"	17 7/8"	18"	3/4"	2 1/8"
HMSP-2012-0625	2 1/4"	12"	5/8"	1 5/8"	17 1/4"	18"	3/4"	2 1/8"
HWSP-1506-0750	1 3/4"	6"	3/4"	1 1/2"	12 5/8"	13"	11/16"	2 3/4"
HWSP-1508-0750	1 3/4"	8"	3/4"	1 1/2"	14 5/8"	15 1/4"	11/16"	2 3/4"
HWSP-1510-0750	1 3/4"	10"	3/4"	1 1/2"	16 5/8"	17 1/4"	11/16"	2 3/4"
HWSP-1510-1000	1 3/4"	10"	1"	1 1/2"	16 5/8"	17"	11/16"	2 3/4"
HWSP-2006-0750	2 1/4"	6"	3/4"	2"	12 5/8"	13 3/16"	3/4"	2 3/4"
HWSP-2010-1000	2 1/4"	10"	1"	2"	16 5/8"	17 1/4"	11/16"	2 3/4"
HWSP-2016-1000	2 1/4"	16"	1"	2"	22 5/8"	23 5/16"	3/4"	2 9/16"

MODEL NUMBER H A SP - 175 - 12 - 0750 - 00

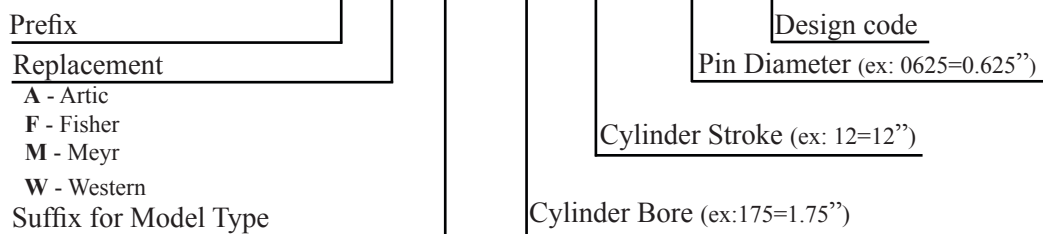

SNOW PLOW HYDRAULIC CYLINDERS

HTC- Telescopic Cylinder for 7 tons and 12 tons inverse.

TELESCOPIC CYLINDERS

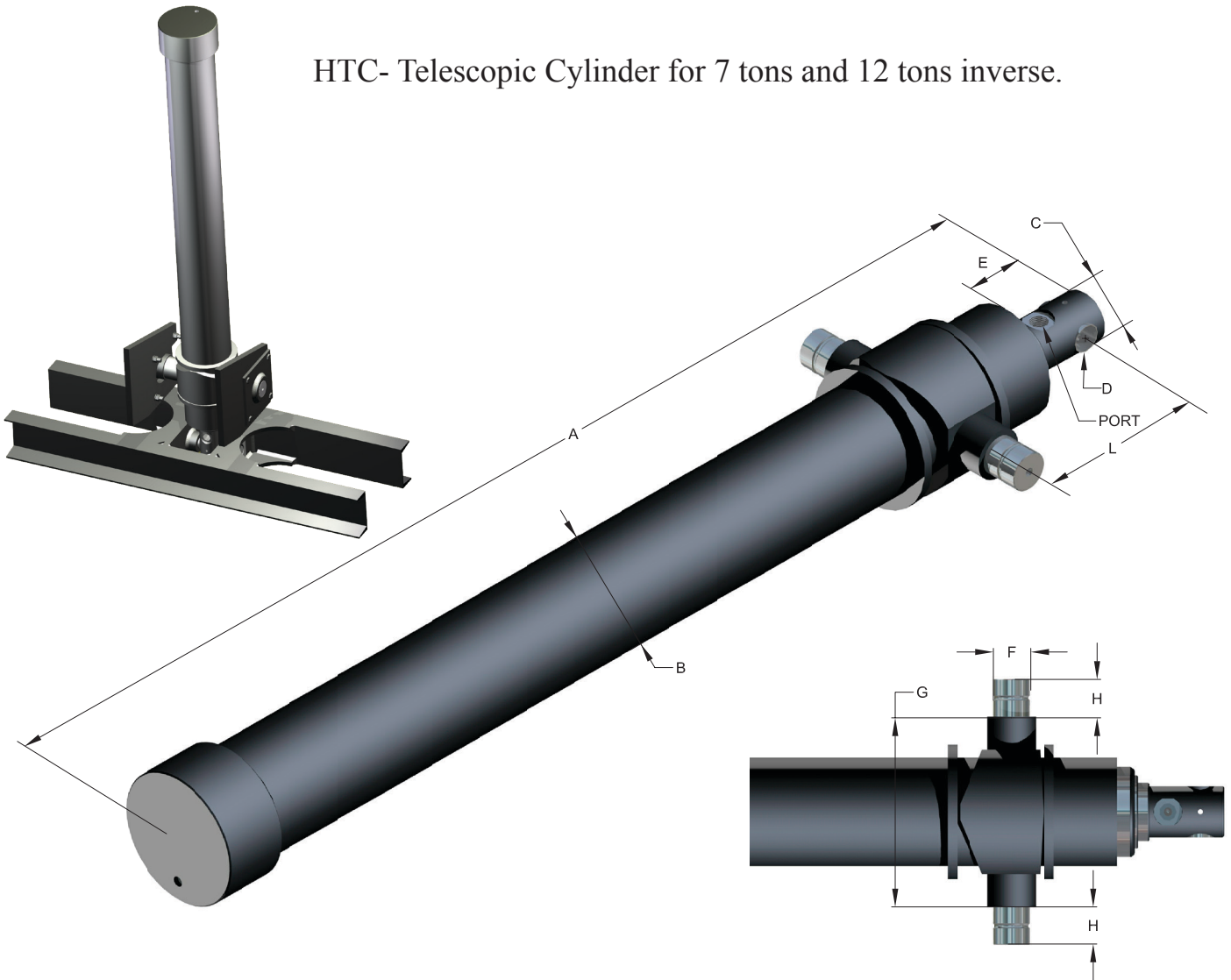

7 TONS INVERSE													
PART No.	STROKE	A	B	C	D	E	F	G	H	L	PORTS	WEIGHT [Lbs]	VOLUME [Gal.]
HTC-07833	78"	35.5"	3.75"	2"	1.063"	3.0"	1.25"	6.5"	1.25"	7"	SAE #8 (3/4-16UNF)	68	1.6
HTC-09033	90"	39.5"	3.75"	2"	1.063"	3.0"	1.25"	6.5"	1.25"	7"		75	1.8
HTC-10833	108"	45"	3.75"	2"	1.063"	3.0"	1.25"	6.5"	1.25"	7"		101	2.2
12 TONS INVERSE													
HTC-07843	78"	34.75"	4.4"	2"	1.063"	3.0"	1.5"	7.5"	1.5"	7"	SAE #8 (3/4-16UNF)	106	2.5
HTC-09043	90"	38.75"	4.4"	2"	1.063"	3.0"	1.5"	7.5"	1.5"	7"		107	2.8
HTC-10843	108"	44.75"	4.4"	2"	1.063"	3.0"	1.5"	7.5"	1.5"	7"		132	2.4
HTC-12043	120"	48.75"	4.4"	2"	1.063"	3.0"	1.5"	7.5"	1.5"	7"		143	3.8

All pictures may differ from the final products. Product specifications are subject to changes without notice.

ORDER INFORMATION

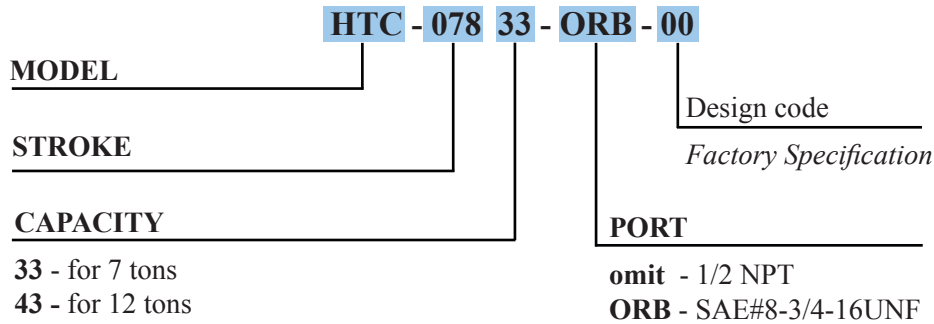

ACCESSORIES FOR TELESCOPIC CYLINDERS

MOUNTING BTACKETS

HTCS07-A
for 7 tons

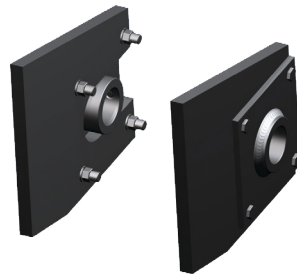
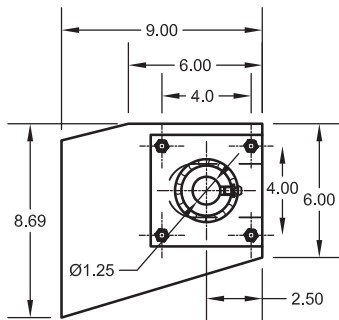

HTCS12-A
for 12 tons

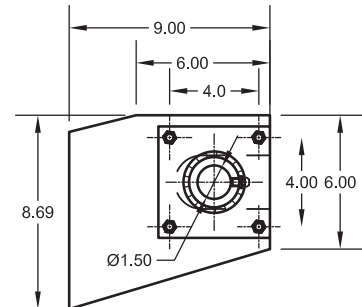

SUPPORT FRAME for 7 and 12 tons

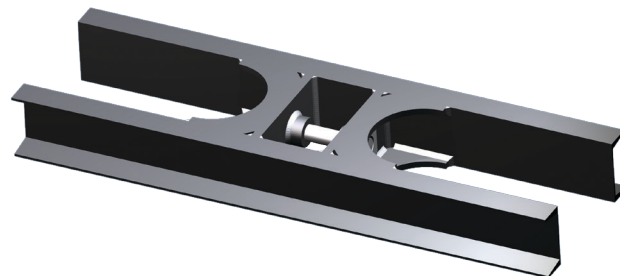
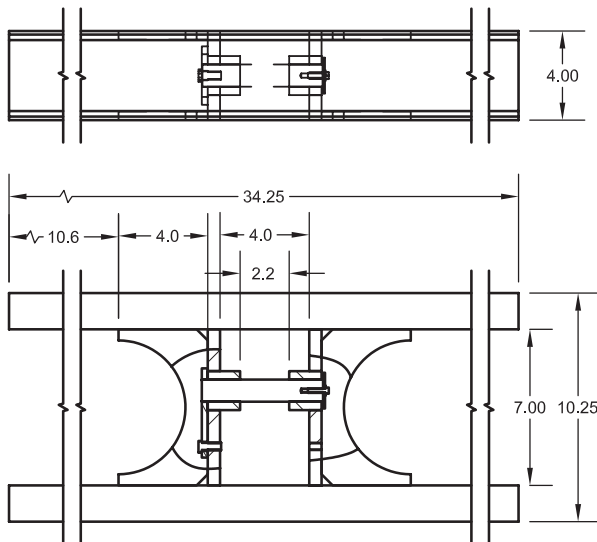

TELESCOPIC CYLINDERS

CUSTOM ENGINEERED CYLINDERS

Contact us for all your special cylinder requirements.

Bore size between 1" to 12"

Stroke lengths 1" TO 150"

Use our form on the next page,
or directly from our internet site.

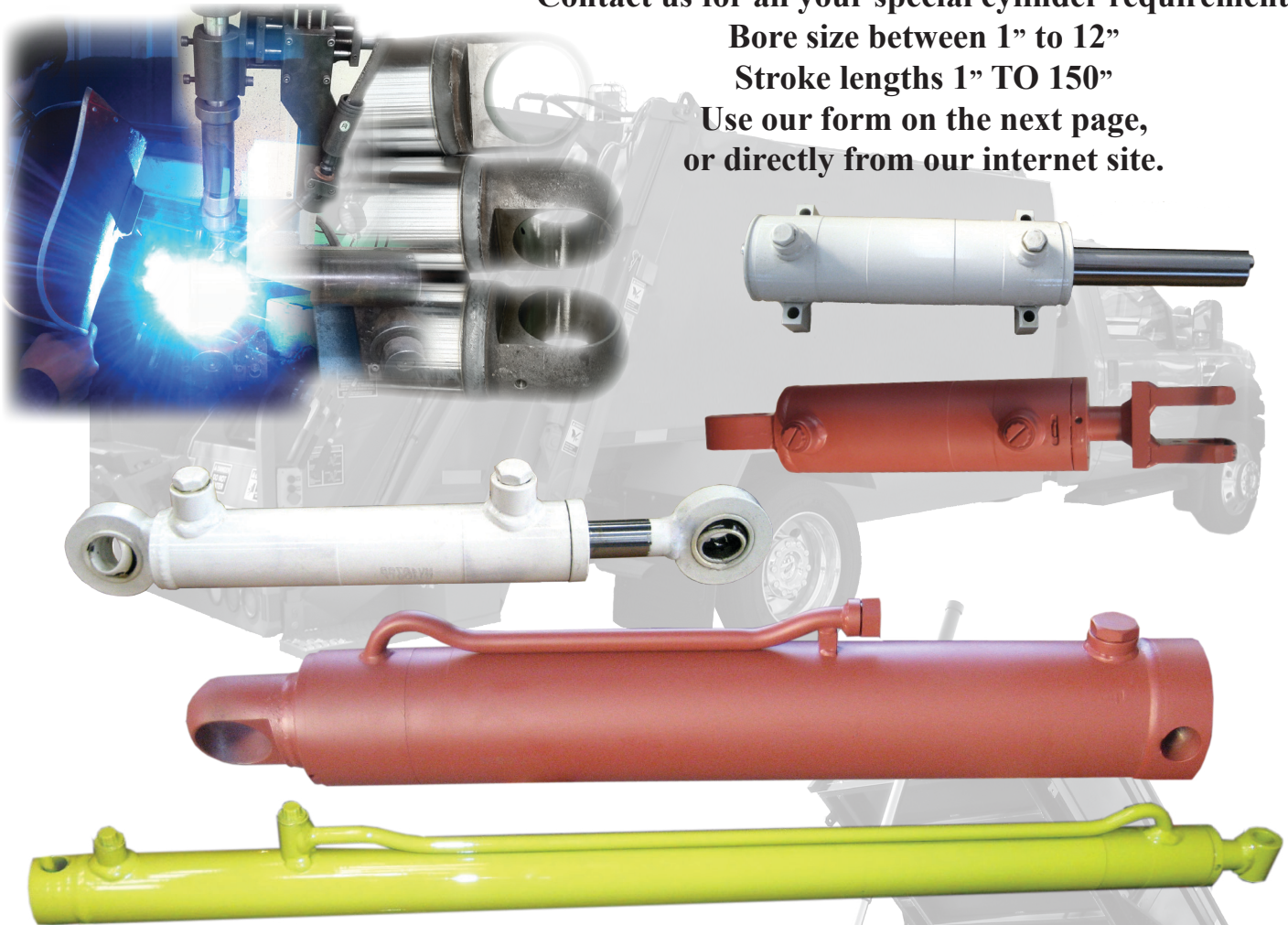

Industry Best Standards:

- * ISO Certified
- * Automated Welding
- * CNC Machining
- * Thread Rolling
- * North American Seals
- * High Quality Chrome / Nitride
- * Powder Coat Paint Line
- * In House Oil Particle Testing
- * Capital for Future Investment
- * Professional Packaging

CYLINDER DIMENSIONS

METRIC: INCH:

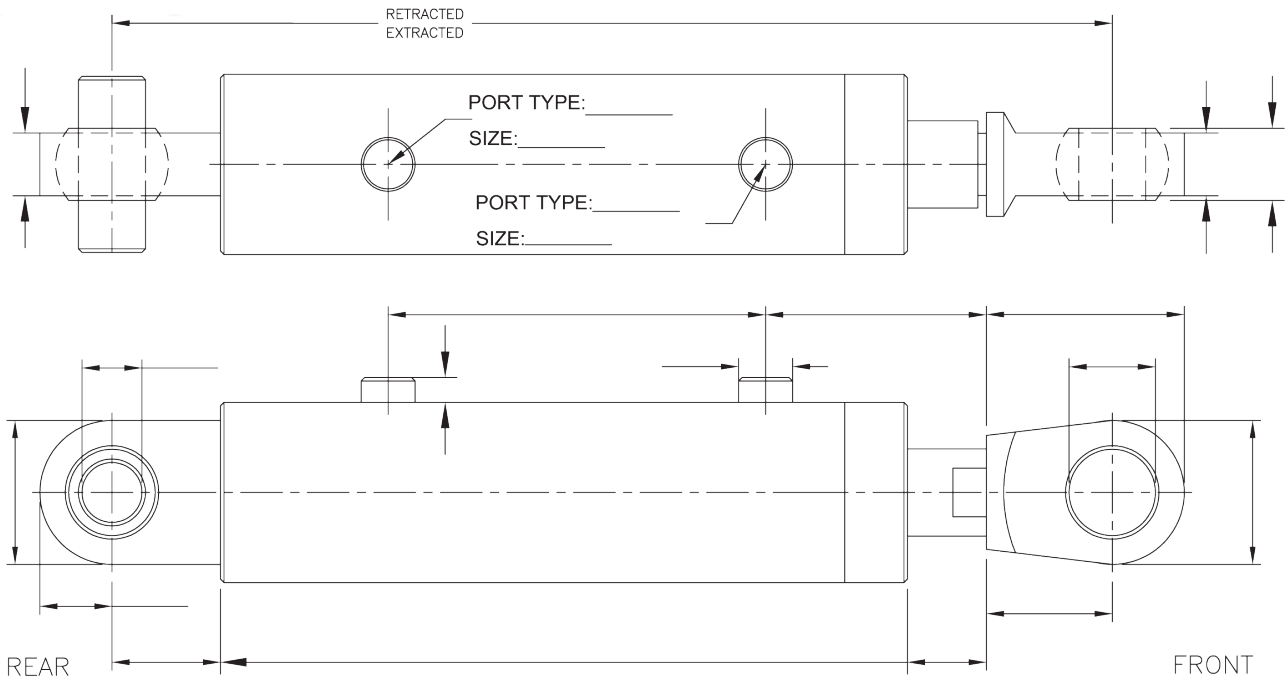

Tube ØOD: _____ Tube ØID: _____
Rod Ø: _____ Stroke: _____
Retracted:
Acting: Single Double
Fluid Type: _____
Pressure (PSI): _____
Paint: _____ Sticker: _____
Stamp: _____

TYPE OF FUNCTION: _____
Application /Special request: _____

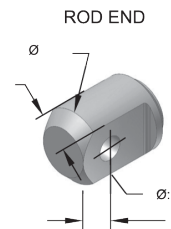
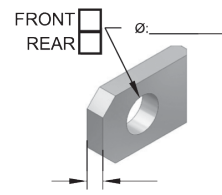
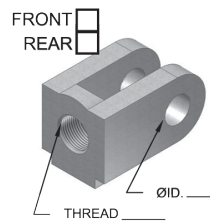
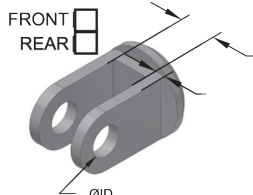
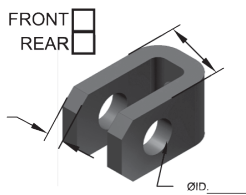
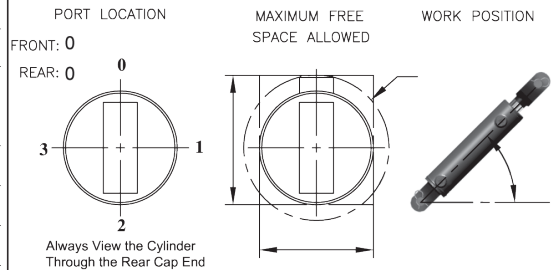

Ø: _____
LENGTH: _____
PIN: _____
TYPE: _____
INCLUDED:
NOT INCLUDED:

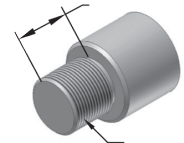
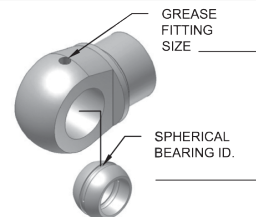
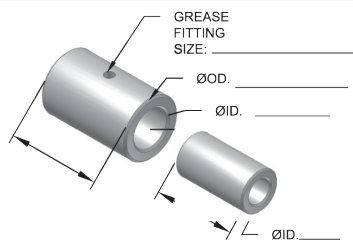

Date Submitted: _____ Contact Name: _____
Company Name: _____ Email: _____
Telephone: (____) _____ Mailing Address: _____
Fax: (____) _____

WARRANTY

1. Warranty policies.

EAGLE Hydraulic components warrants all cylinders to be free from any defects in material or workmanship under normal use and service for a period of two (2) years from the date of manufacture. The manufacture date is laser engraved on the body of every cylinder.

EAGLE's obligation is subject to confirmation of the claim by our inspection department and is limited to the repair or replacement of the part. Warranty administration is solely at discretion of EAGLE, F.O.B. our facility in Mirabel, Quebec, Canada. EAGLE, at our discretion may direct that this service be performed at an approved service location. Any defect corrected within the warranty period will be at the expense of EAGLE.

This warranty does not cover & EAGLE shall have no responsibility for:

- Troubleshooting, diagnostic, removal, or reinstallation labor charges;
- Freight charges for either defective parts or new or repaired parts unless prior written approval is obtained from EAGLE;
- Claims for loss of time, inconvenience, loss of use, profits or other consequential damages;
- Conditions from, alteration, accident, misuse, neglect, fire, theft, loss, intentional damage, direct, indirect, consequential, incidental, weather related, or any other type of damage resulting from the use of the product;
- Corrosion unless the material is found to be out of specification;
- Failure due to contamination introduced to the cylinder;
- Paint unless out of specification;
- Normal wear of internal components

This warranty is null & void should the product be dismantled, opened, or serviced by anyone other than an authorized representative of EAGLE Hydraulique.

2. Warranty procedures.

Should you have a valid reason to exercise warranty on a cylinder. Please contact our Customer Service department either by phone 1-877-382-2850 or by e-mail at service@eagle-hydraulic.com. Be prepared to answer the following:

- a. Description of failure.
- b. Cylinder model and manufacturing date as laser engraved on all cylinders.
- c. Invoice number and date.

Our Customer Service department will assign a file number to your request and will inform you on subsequent action. If we decide to have the cylinder returned for inspection, we will assign an RGA (return goods authorization) number and you will need to make arrangements to return the cylinder to our facility. We will not accept any cylinders returned without a valid RGA number. The Company will deploy necessary resources to resolve all warranty issues within 90 days of notification.

This warranty is expressly in lieu of any other warranties, expressed or implied, including any implied warrant of merchantability or fitness for a particular purpose, and of any non-contractual liabilities including liabilities for personal injury or property damage or any other product liabilities based upon negligence or strict liability. Any additional or different liabilities assumed by eagle must be contained in writing and signed by an authorized employee of eagle.

MORE HYDRAULIC MOTORS

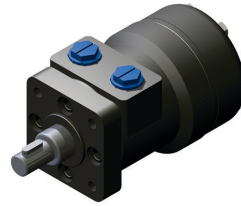

CROSS OVER RELIEF VALVE

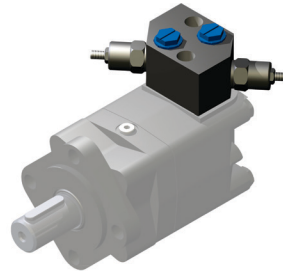

DC POWER UNITS

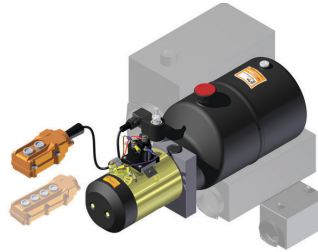

VANE PUMPS



HIGH PRESSURE GEAR PUMPS



17550 rue Charles, Mirabel, Qc, Canada, J7J 1X9

Tel : 450-433-2800 / 1-877-382-2850

Fax : 450-433-3004 / 1-877-382-2853

www.eagle-hydraulic.com

Version 2014