



## Whynter NEX Inverter Dual Hose Portable Air Conditioner with Wi-Fi & LCD Remote

MODEL: ARC-1030WN / ARC-1230WN/ARC-1230WNH



Congratulations on your new Whynter product. To ensure proper operation, please read this Instruction Manual carefully before using this product. Keep this manual in a safe place for future reference.

## DISPOSAL INFORMATION

Thank you for choosing Whynter. Please follow the instructions provided in this user manual to obtain the very best performance from your steam oven. We trust that your Whynter steam oven will provide the performance and reliability that we stand for.

Please keep this user manual in a safe place for future reference.

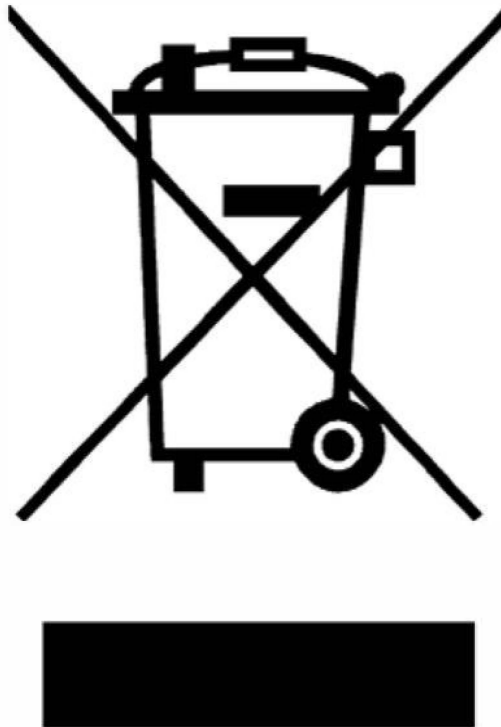

This symbol on the product or its packaging indicates that this appliance cannot be treated as normal domestic trash, but must be handed in at a collection point for recycling electric and electronic appliances. Your contribution to the correct disposal of this product protects the environment.

Further information about the recycling of this product can be obtained from your local municipal authority.

## Table of Contents

	<u>PAGE</u>
SAFETY PRECAUTIONS	4
SAFETY COMPLIANCE	5
PREPARATION	6
INTRODUCTION / TECHNICAL DATA	7
ACCESSORIES	8
WINDOW KIT INSTALLATION	8 - 10
CONTROL PANEL	11 - 12
OPERATION INSTRUCTIONS	13 - 14
REMOTE CONTROL	15 - 16
CLEANING AND MAINTENANCE	16 - 17
TROUBLESHOOTING	18 - 19
WARRANTY	20



Caution: Risk of fire/  
flammable materials  
(Required for R32/R290 units only)



### IMPORTANT NOTE:

Read this manual carefully before installing or operating your new air conditioning unit. Make sure to save this manual for future reference.

Explanation of symbols displayed on the unit(For the unit adopts R32/R290 Refrigerant only):

	WARNING	This symbol shows that this appliance used a flammable refrigerant. If the refrigerant is leaked and exposed to an external ignition source, there is a risk of fire.
	CAUTION	This symbol shows that the operation manual should be read carefully.
	CAUTION	This symbol shows that a service personnel should be handling this equipment with reference to the installation manual.
	CAUTION	This symbol shows that information is available such as the operating manual or installation manual.

## SAFETY PRECAUTIONS

### Read Safety Precautions Before Operation and Installation

To prevent death or injury to the user or other people and property damage, the following instructions must be followed. Incorrect operation due to ignoring of instructions may cause death, harm or damage.

- Installation must be performed according to the installation instructions. Improper installation can cause water leakage, electrical shock, or fire.
- Use only the included accessories and parts, and specified tools for the installation. Using non-standard parts can cause water leakage, electrical shock, fire, and injury or property damage. Make sure that the outlet you are using is grounded and has the appropriate voltage.
- The power cord is equipped with a three-prong grounding plug to protect against shock.
- Voltage information can be found on the nameplate of the unit.
- Your unit must be used in a properly grounded wall receptacle. If the wall receptacle you intend to use is not adequately grounded or protected by a time delay fuse or circuit breaker (the fuse or circuit breaker needed is determined by the maximum current of the unit. The maximum current is indicated on the nameplate located on unit), have a qualified electrician install the proper receptacle.
- Install the unit on a flat, sturdy surface. Failure to do so could result in damage or excessive noise and vibration.
- The unit must be kept free from obstruction to ensure proper function and to mitigate safety hazards.
- Do not modify the length of the power cord or use an extension cord to power the unit.
- Do not share a single outlet with other electrical appliances. Improper power supply can cause fire or electrical shock.
- Do not install your air conditioner in a wet room such as a bathroom or laundry room. Too much exposure to water can cause electrical components to short circuit.
- Ensure there is a minimum of 36" clearance around the unit and is clear from any combustible items such as propane, fire extinguishers, fuel, etc.
- The exhaust hose should always be used and should never be covered or blocked which can become a fire hazard.
- The unit has wheels to facilitate moving. Make sure not to use the wheels on thick carpet or to roll over objects, as these could cause tipping.
- Do not operate a unit that it has been dropped or damaged.
- Do not place the portable air conditioner close to any other heat generating appliances
- Do not touch the unit with wet or damp hands or when barefoot.
- If the air conditioner is knocked over during use, turn off the unit and unplug it from the main power supply immediately. Visually inspect the unit to ensure there is no damage. If you suspect the unit has been damaged, contact a technician or customer service for assistance.
- In a thunderstorm, the power must be cut off to avoid damage to the machine due to lightning.
- Your air conditioner should be used in such a way that it is protected from moisture. e.g. condensation, splashed water, etc. Do not place or store your air conditioner where it can fall or be pulled into water or any other liquid. Unplug immediately if it occurs.
- All wiring must be performed strictly in accordance with the wiring diagram located inside of the unit.
- The unit's circuit board (PCB) is designed with a fuse to provide overcurrent protection. The specifications of the fuse are printed on the circuit board, such as: T 3.15A/250V, etc.
- When the water drainage function is not in use, keep the upper and the lower drain plug firmly plugged into to the unit to prevent choking.

## CAUTION

- This appliance is not intended for use by persons (including children) with reduced physical, sensory or mental capabilities or lack of experience and knowledge, unless they have been given supervision or instruction concerning use of the appliance by a person responsible for their safety. Children should be supervised to ensure that they do not play with the appliance.
- Children must be supervised around the unit at all times.
- If the supply cord is damaged, it must be replaced by the manufacturer, its service agent or similarly qualified persons in order to avoid a hazard.
- Prior to cleaning or other maintenance, the appliance must be disconnected from the supply mains.
- Do not remove any fixed covers. Never use this appliance if it is not working properly, or if it has been dropped or damaged.

## CAUTION

- Do not remove any fixed covers. Never use this appliance if it is not working properly, or if it has been dropped or damaged.
- Do not run cord under carpeting. Do not cover cord with throw rugs, runners, or similar coverings. Do not route cord under furniture or appliances. Arrange cord away from traffic area and where it will not be tripped over.
- Do not operate unit with a damaged cord, plug, power fuse or circuit breaker. Return to an authorized service facility for examination and/or repair.
- To reduce the risk of fire or electric shock, do not use this fan with any solid-state speed control device.
- The appliance shall be installed in accordance with national wiring regulations.
- Contact the manufacturer or authorized service technician for repair or maintenance information of this unit.
- Contact the manufacturer or authorized installer for installation questions of this unit.
- Do not cover or obstruct the inlet or outlet grilles.
- Do not use this product for functions other than those described in this instruction manual.
- Before cleaning, turn off the power and unplug the unit.
- Disconnect the power if strange sounds, smell, or smoke comes from it and contact the manufacturer or authorized service technician for assistance.
- Do not press the buttons on the control panel with anything other than your fingers.
- Do not remove any fixed covers. Contact Whynter Customer Support if this unit if it is not working properly, or if it has been dropped or damaged.
- Do not operate or stop the unit by inserting or pulling out the power cord plug.
- Do not use hazardous chemicals to clean or come into contact with the unit. Do not use the unit in the presence of inflammable substances or vapor such as alcohol, insecticides, petrol, etc. Always transport your air conditioner in a vertical position and stand on a stable, level surface during use.
- Always contact Whynter Customer Support for replacement parts compatible with your unit. Hold the plug by the head of the power plug when taking it out.
- Turn off the product when not in use.

## WARNING

- The appliance shall be stored in a room without continuously operating ignition sources (for example: open flames, an operating gas appliance or an operating electric heater).
- Do not pierce or burn the unit.
- Be aware that the refrigerants may not contain an odor.

## SAFETY COMPLIANCE

- Keep ventilation openings clear of obstruction.
- The appliance shall be stored so as to prevent mechanical damage from occurring.
- A warning that the appliance shall be stored in a well-ventilated area where the room size corresponds to the room area as specified for operation.
- Any person who is involved with working on or breaking into a refrigerant circuit should hold a current valid certificate from an industry-accredited assessment authority, which authorizes their competence to handle refrigerants safely in accordance with an industry recognized assessment specification.
- Servicing shall only be performed as recommended by the equipment manufacturer.
- Maintenance and repair requiring the assistance of other skilled personnel shall be carried out under the supervision of the person competent in the use of flammable refrigerants.
- Please follow the instructions carefully to handle, install, clear, and service the air conditioner to avoid any damage or hazard. Flammable Refrigerant R32 is used within air conditioner. When maintaining or disposing the air conditioner, the refrigerant (R32) shall be recovered properly and shall not discharge to air directly.
- No any open fire or device which may generate spark/arc shall be around air conditioner to avoid causing ignition of the flammable refrigerant used.
- Please follow the instruction carefully to store or maintain the air conditioner to prevent mechanical damage from occurring.
- Flammable refrigerant R32 is used in air conditioner. Please follow the instruction carefully to avoid any hazard. For specific information on the type of gas and the amount, please to the relevant label on the unit itself.

## PREPARATION

All illustrations in the manual are for explanation purpose only. Your machine may be slightly different. The actual shape shall prevail. The unit can be controlled by the unit control panel alone or with the remote controller.

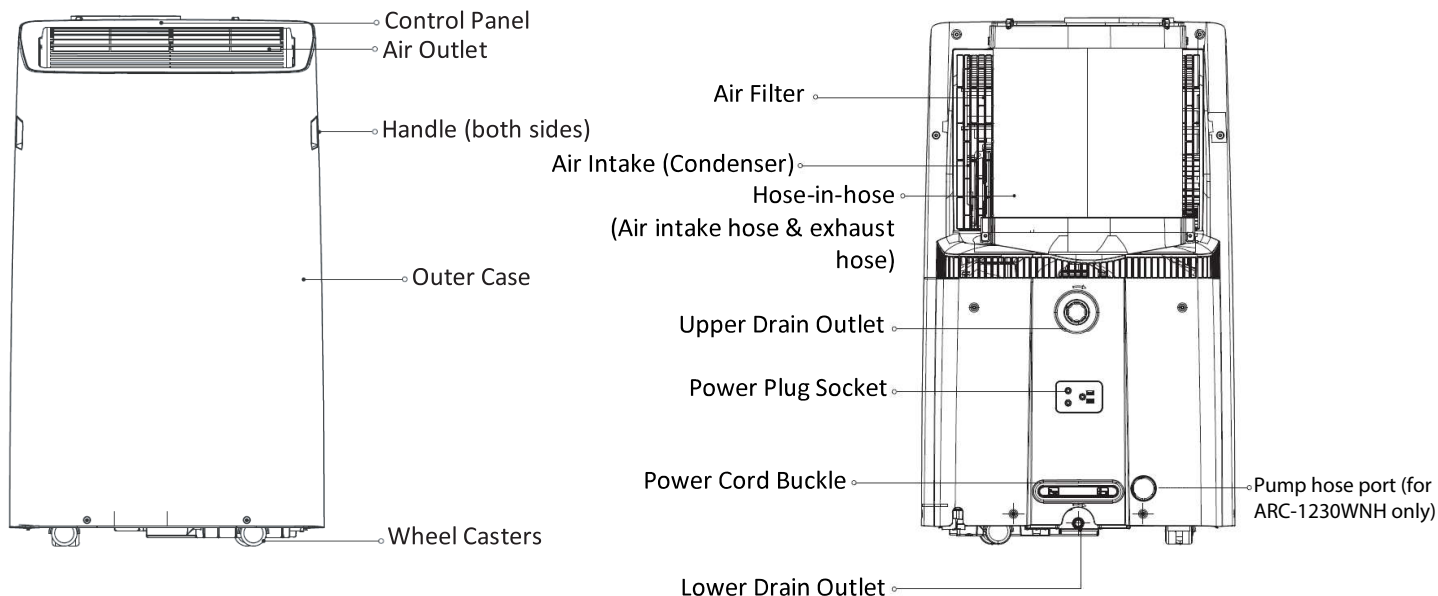

## DESIGN NOTICE

In order to ensure the optimal performance of our products, the design specifications of the unit and remote control are subject to change without prior notice.

## EXHAUST HOSE INSTALLATION

The innovative hose-in-hose design delivers more than 2x faster and stronger cooling. The hoses and adapter must be installed or removed in accordance with the usage mode. For COOL mode & HEAT mode (only for ARC-1230WNH), the adapter and exhausts must be installed. For FAN or DRY mode, the adapter and exhaust hoses can optionally be removed.

## CHOOSING THE RIGHT LOCATION

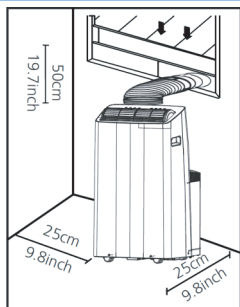

Your installation location should meet the following requirements:

- Make sure that you install your unit on an even surface to minimize noise and vibration.
- The unit must be installed near a grounded plug, and the Collection Tray Drain (found on the back of the unit) must be accessible.
- The unit should be located at least 25cm (9.8") from the nearest wall to ensure proper air conditioning. The horizontal louver blade should be at least 50cm (19.7") away from obstacles.
- DO NOT cover the Intakes, Outlets or Remote Signal Receptor of the unit, as this could cause damage to the unit.

## AMBIENT TEMPERATURE RANGE FOR UNIT OPERATION

MODE	TEMPERATURE RANGE
Cool	62-95°F   17-35°C
Dry	62-95°F   17-35°C
Heat (heat pump mode)	41-86°F   5-30°C (only for ARC-1230WNH)

# INTRODUCTION

## INTRODUCTION TO INVERTER TECHNOLOGY

As pioneers in the air comfort space, we are introducing next generation technology currently used only in high efficiency ductless mini-split air conditioners. The Inverter technology will be featured in our NEX line of portable air conditioners. By utilizing this much more efficient technology, Whynter's Inverter variable-speed system allows the compressor to optimize efficiency and power consumption together, while maintaining a specified output.

This allows for a much quieter operation and significantly reduced energy consumption. The Inverter technology system potentially reduces energy usage by more than 40% while the new hose-in-hose design delivers more than double the cooling output. Below are the advantages of inverter technology:

- At least 40% - 50% cheaper to run as it consumes less power
- Quicker to achieve desired temperature
- Quieter operation
- No temperature fluctuations
- No voltage peaks from compressor

## HOSE-IN-HOSE COOLING SETUP

The innovative two-hose in one design and the sealed bottom structure ensure no heat leakage. This cooling setup extracts and exhausts air from the outdoor, so the indoor space reaches an independent and balanced cool air circulation. As a result, the entire room can be cooled down quickly and effectively.

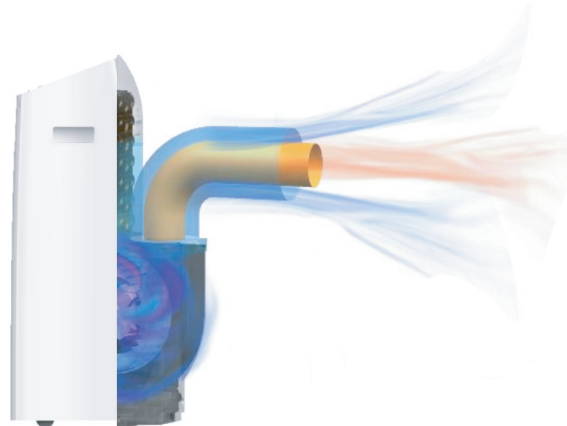

Model	ARC-1030WN	ARC-1230WN	ARC-1230WNH
Operational Modes	Cool / Fan / Dry	Cool / Fan / Dry	Cool / Fan / Dry / Heat
Cooling Capacity	12,000 BTU   SACC 10,000 BTU	14,000 BTU   SACC 12,000 BTU	14,000 BTU   SACC 12,000 BTU
Heating Capacity	-	-	12,000 BTU
Coverage Area	500 sq. ft.	600 sq. ft.	600 sq. ft.
Fan Speed	Continuous   Auto   Low   Medium   High	Continuous   Auto   Low   Medium   High	Continuous   Auto   Low   Medium   High
Noise Level	42.5 / 49.5 / 53.5	42.5 / 49.5 / 56.5	47.2 / 52.6 / 56.8
Temperature Range	60-86°F	60-86°F	Cooling: 60-86°F   Heating: 60-86°F
Timer	Up to 24 hours	Up to 24 hours	Up to 24 hours
Refrigerant	R32	R32	R32
Power Consumption	1266W	1293W	1298W
Amps	11.8	11.9	11.9
Power Supply	115V/60Hz	115V/60Hz	115V/60Hz
CEER   EER	12.3   10.0	12.3   10.8	12.3   10.8
Net Weight	72.8 lbs	75 lbs	77.2 lbs
Unit Dimensions	19.5" W x 16.7" D x 32.5" H	19.5" W x 16.7" D x 32.5" H	19.5" W x 16.7" D x 32.5" H

## WHAT SHOULD I LOOK FOR WHEN PURCHASING A PORTABLE AIR CONDITIONER?

The right air conditioner helps you cool a room efficiently. An undersized unit won't cool adequately while one that's too large will not remove enough humidity, leaving the air feeling damp. To find the proper air conditioner, determine the square footage of the room you want to cool by multiplying the room length by its width. You also need to know the air conditioner's BTU (British Thermal Unit) rating, which indicates the amount of heat it can remove from a room. Why is the cooling capacity lower on newer models than on older units? A higher number means more cooling power for a larger room. (Be sure you are comparing only newer models to each other- older models may appear to have a higher capacity, but are actually the same). Be sure to "size up" if your portable air conditioner will be placed in a very sunny room, in a kitchen, or in a room with high ceilings. After you've found the right cooling capacity for your room, you can look at other features.

## WHY IS THE COOLING CAPACITY LOWER ON NEWER MODELS THAN OLDER MODELS?

Federal regulations require manufacturers to calculate cooling capacity based on a specific test procedure, which was changed just this year. Models manufactured before 2017 were tested under a different procedure and cooling capacity is measured differently than in previous models. So, while the BTUs may be lower, the actual cooling capacity of the air conditioners has not changed.

## WHAT IS SACC?

SACC is the representative value of Seasonally Adjusted Cooling Capacity, in Btu/h, as determined in accordance with the DOE test procedure at title 10 Code of Federal Regulations (CFR) 430, subpart B, appendix CC and applicable sampling plans.

## ACCESSORIES

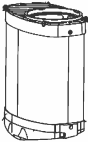





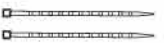





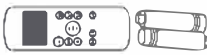

Image	Accessory Description	Qty
	Hose-in-hose (Air intake hose & exhaust hose)	1 set
	Air outlet adapter	1 piece
	Exhaust Connector Module A B C*	1 piece each
	Window Slider A	1 piece
	Window Slider B	1 piece
	Foam Seal A (Adhesive)	2 pieces
	Ribbon (only for heat pump model)	2 pieces

Image	Accessory	Qty
	Foam Seal B (Adhesive)	2 pieces
	Foam Seal C (Non-Adhesive)	1 pieces
	Security Bracket	1 set
	Drain Hose	1 piece
	Power Cord Buckle (only for cooling model)	1 piece
	Bolt	1 piece
	Remote Control	1 set
	Drain Hose Adaptor	1 piece

## WINDOW KIT INSTALLATION

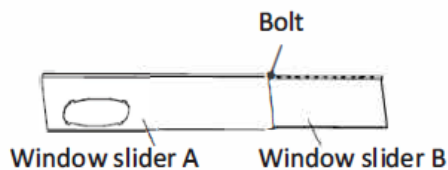

### Adjustable Window Slider Option

1. Measure the window opening where the window kit will be installed.
2. Assemble as many sliders as necessary to fit the window. If the window opening is less than the minimum length of a single slider, use the slider that has the hole in it and cut it to the correct length. Make sure not to cut the end that has the hole as this is necessary to attach the exhaust hose adapter.
3. Use the window slider bolts to secure the window sliders at the correct length.

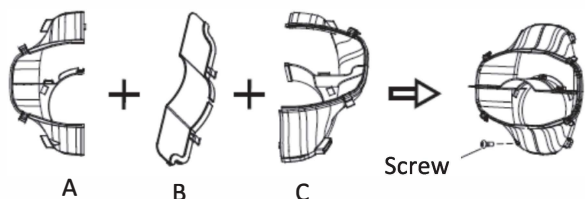

### Hoses Connector Modules (For Sliding Window)

Assemble the exhaust adapter module for sliding windows using the exhaust connector screw as shown. The window slider is eccentric so the exhaust adapter must be installed away from the wall.

### Hose-in-hose

1. Rotate the exhaust hose gently backwards.
2. Pull out the exhaust hose away from the wall.

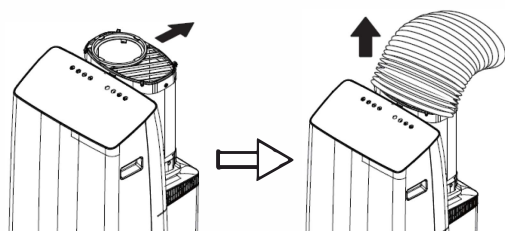

**NOTE:** To ensure proper functioning, DO NOT overextend or bend the hose. Make sure that there is no obstacle around the air outlet of the exhaust hose (in the range of 500mm) in order for the exhaust system to work properly. All illustrations in this manual are for explanation purposes only. Your air conditioner may be slightly different. The actual shape shall prevail.



# WINDOW KIT INSTALLATION

NOTE: Once the Exhaust Hose assembly and Adjustable Window Slider are prepared, choose from one of the following two installation methods.

## Hung Window or Sliding Window Installation

1. Cut adhesive foam seals A and B to the correct lengths and attach them to the window frame as shown.

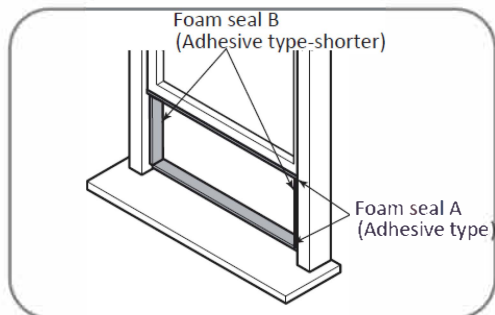

Or

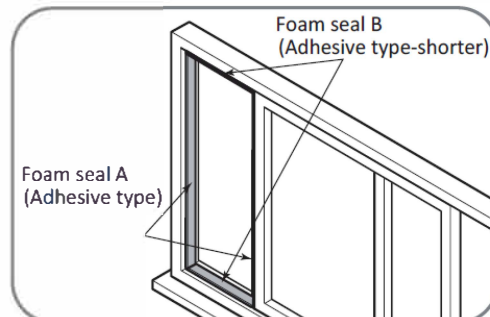

2. Insert the window slider kit into the window opening and close the window the secure it in place.

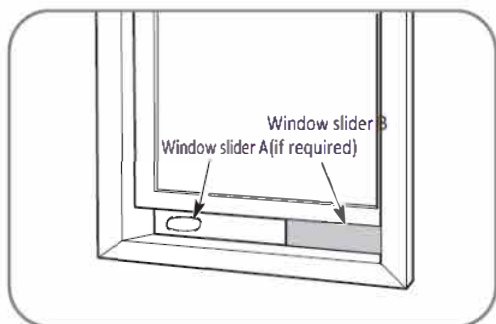

Or

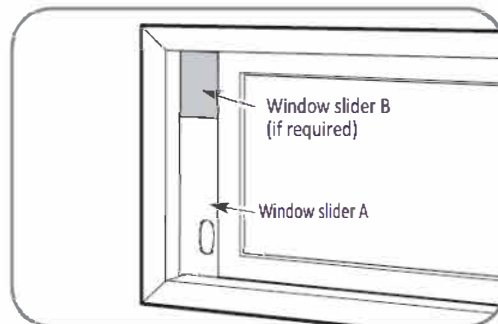

3. Cut the non-adhesive foam seal C to match the width or height of the window and insert it between the panes of glass as shown to prevent outside air from entering the window.

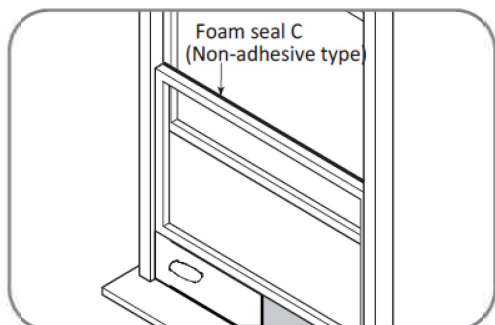

Or

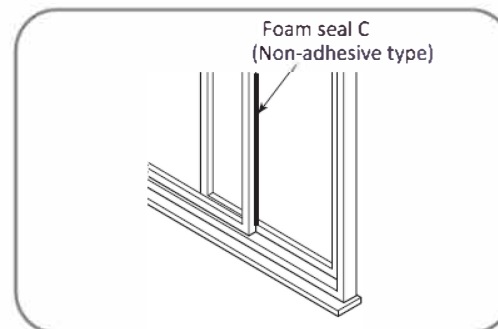

# WINDOW KIT INSTALLATION

NOTE: Once the Exhaust Hose assembly and Adjustable Window Slider are prepared, choose from one of the following two installation methods.

## Hung Window or Sliding Window Installation

4. If desired, install the security bracket with 2 screws as shown.

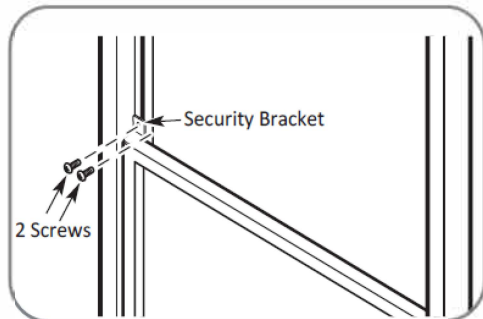

Or

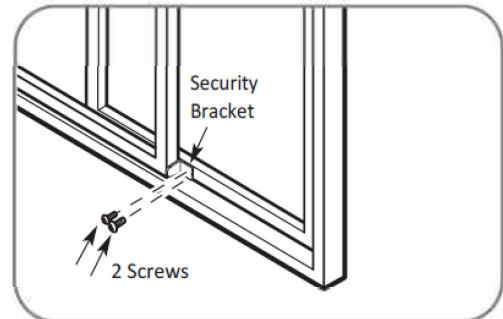

5. For a hung window, attach the air outlet adapter onto the exhaust hose and rotate it 90° to secure it in place. For a sliding window, attach the exhaust adapter onto the exhaust hose.

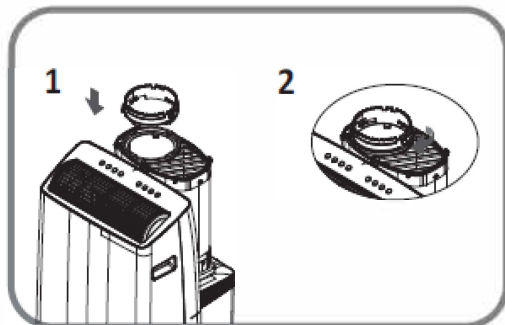

Or

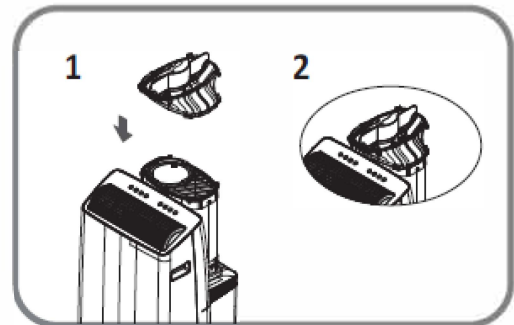

6. For a hung window, attach the air outlet adapter onto the window slider kit. For a sliding window, attach the exhaust adapter onto the window slider kit.

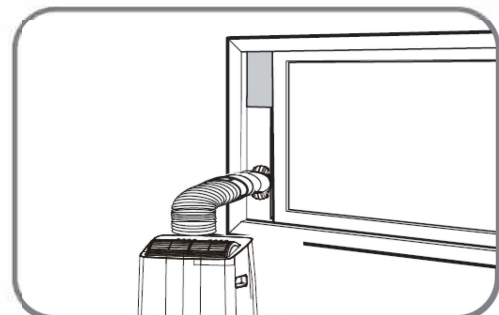
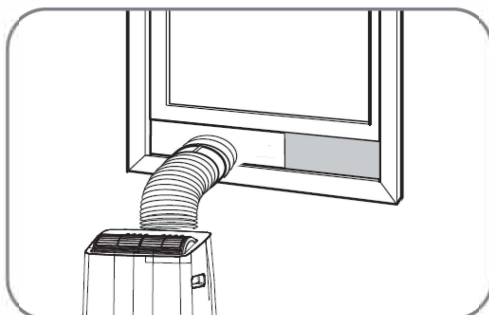

# CONTROL PANEL

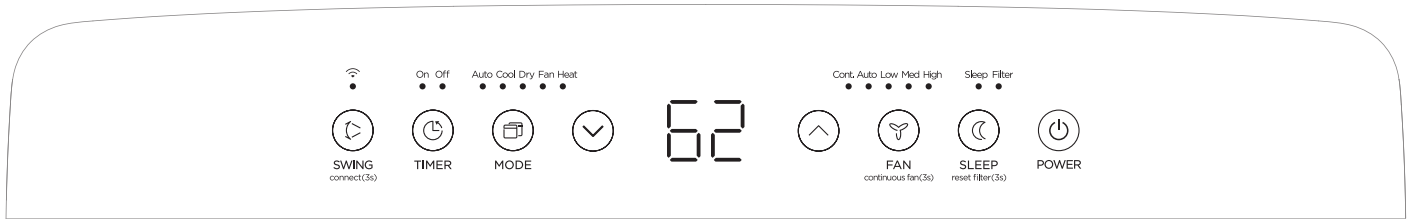

## DISPLAY ICONS

### Wireless feature (Wi-Fi enabled models only)

Illuminates to show wireless connection is activated.

### The timer on/off indicator light

Press and hold on TIMER button for 3 seconds to cancel timing function.

### Operation Mode Indicator Lights

Illuminates to show current mode operation.

### LED Display

Shows the set temperature in °F or °C and the Auto-timer settings. While on FAN modes, it shows the room temperature.

### Fan Speed Indicator Lights

Illuminates to show the set fan speed.

### Sleep Indicator Light

Illuminates when Sleep Mode is activated.

### Filter Indicator Light

The LED will illuminate after 250 hours of operation. This feature is a reminder to clean the Air Filter for more efficient operation.

## CONTROL BUTTONS

### Swing / Wireless Mode

#### **Auto-swing**

Press to start the auto swing feature. When the operation is ON, press the SWING button to stop the louver at a desired angle.

#### **Turn on Wireless connection mode**

To turn on Wireless connection mode on, press and hold the swing button for 3 seconds and the LED display will show “AP” for 3 seconds. Follow the instructions on the Wi-Fi setup manual and the latest app version available for your phone operating system.

#### **Turn off Wireless connection mode**

Once the wireless connection mode is successful, press and hold the swing and down buttons for 3 seconds and the LED display will show “OF” for 3 seconds.

#### **Connection Successful**

If the connection is successful within 8 minutes, the unit will exit wireless connection mode automatically and the wireless indicator will illuminate.

#### **Connection Failed**

If the connection has failed within 8 minutes, the unit will exit Wireless connection mode automatically.

NOTE: When you restart the wireless functions, it will take a period of time to connect to the network automatically. Always be sure your wireless connection is working properly and there is a valid internet connection for Wi-Fi functionality to work.

### Timer

Press to program timer delayed switch ON or OFF function.

### Modes

Press to change modes. Controls the functions modes: AUTO, COOL, DRY, FAN, and HEAT\*.

\*only for ARC-1230WNH

# CONTROL PANEL

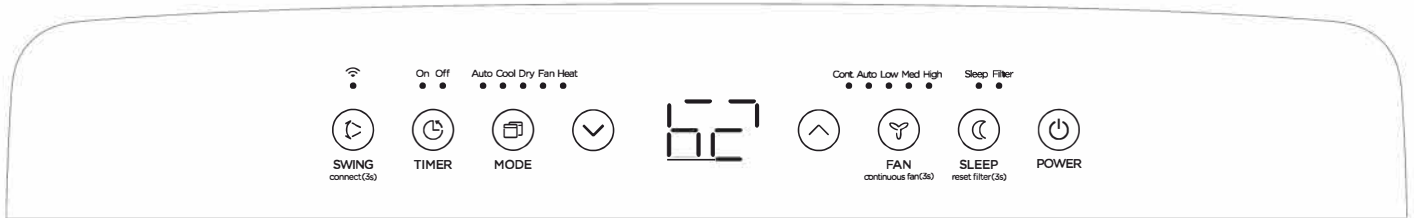

## CONTROL BUTTONS

### Up and Down buttons

Adjusts set temperature 1°F | 1°C increments or timer hours (0 - 24 hours).

*NOTE: This unit is capable of displaying set temperature in Fahrenheit or Celsius. To convert from one to another, press and hold the Up and Down buttons for 3 seconds.*

### Fan

Press to change fan speed. Controls the 5 fan speeds and mode: Continuous, Auto, Low, Medium, and High.

*NOTE: In Auto and Dry mode, the fan speed control is disabled Continuous Fan Mode. Press and hold to select continuous fan speed. The fan speed will keep on operating in a continuous speed based on the last fan speed setting.*

### Sleep Mode

Press to activate Sleep mode. Press SLEEP button again to stop the sleep operation.

*NOTE: This feature is not available in FAN or DRY mode.*

### Filter

Press SLEEP button for 3 seconds to initiate the filter feature.

### Power

Press to turn the air conditioner on and off.

## ERROR CODES

### E1 - Room temperature sensor error

Unplug unit and restart in 5 minutes

### E2 - Evaporator sensor error

Unplug unit and restart in 5 minutes

### E3 - Condenser sensor error

Unplug unit and restart in 5 minutes

### E4 - Display panel sensor error

Unplug unit and restart in 5 minutes

### P1 - Water reservoir full

Drain water from the unit

# OPERATION INSTRUCTIONS

## BEFORE USING YOUR APPLIANCE

- Remove the exterior and interior packing
- Before connecting the appliance to the power source, let it stand upright for approximately 4 hours. This will reduce the possibility of a malfunction in the cooling system from handling during transportation

## SWITCHING ON/OFF THE AIR CONDITIONER

The appliance can be switched ON or OFF by pressing the POWER button on the control panel or the ON/OFF button on the remote control

## COOLING MODE

In this mode, the air conditioner cools and dehumidifies the room. To activate this function mode, press the MODE button until the COOL indicator light comes on. When the cooling mode is set, the compressor will start in approximately 3 minutes. In cooling mode, hot air is exhausted from the outdoor exhaust port and the exhaust hose must be connected to exhaust out the hot air. The temperature setting range of this air conditioner is from 60°F / 16°C to 86°F / 30°C. To set the temperature, press the + or - buttons. This air conditioner has a 5°F temperature cushion which if the set temperature is within 5°F of the ambient temperature, the unit runs on fan only mode. This saves energy and prolongs the life of the compressor of the air conditioner. To set the fan speed, press the FAN button. In cooling mode, the difference in noise level between the fan speeds is not very noticeable when the compressor is on. Try setting the unit to Fan only mode, you should be able to hear the difference between high and low fan speed settings.

## DRY (DEHUMIDIFYING) ONLY MODE

In this mode, the air conditioner only dehumidifies the room, the compressor will activate intermittently depending on the ambient temperature and the fan speed is set to LOW. To activate this function mode, press the MODE button until the DRY indicator light is displayed. Please note that when switching function mode, there will be an approximately 3 minute transition time. In dehumidifying mode, the exhaust hose does not need to be vented. If the exhaust hose is vented, the room will be cooled as it dehumidifies. To prevent cooling, remove the exhaust hose from the window kit and allow the warm air from the rear to be re-circulated into the room. If room temperature is higher than 77°F, the fan speed can be adjusted. If room temperature is lower than 77°F, the fan speed is set at Low.

*NOTE: When using dehumidifying mode, venting the exhaust hose to the outside is not required. If vented, the warm air is exhausted to the outside and cooling within the room may occur. Additionally, if the exhaust hose is not vented, the unit may require more frequent draining. Also, the air conditioner does not have a humidistat in which a specific humidity level can be set.*

## AUTOMATIC MODE

When you set the air conditioner in AUTO mode, it will automatically select cooling or fan only operation depending on what temperature you have selected and the room temperature is close to the unit. The fan speed is automatically selected and cannot be changed. To operate the unit in Auto mode when the unit is on, press the MODE button until the AUTO indicator light comes on.

## HEAT MODE (\*only for ARC-1230WNH)

This air conditioner operates on the heat-pump principle, absorbing heat from air outdoors and transferring that heat to the indoor unit. In this mode, the air conditioner heats the room. To activate this function mode, press the MODE button until the HEAT indicator display comes on. When the heating mode is set, the compressor will start in approximately 3-5 minutes. The heating temperature setting range of this air conditioner is from 60°F - 86°F / 16°C - 30°C. To set the temperature, press the UP and DOWN buttons. To set the fan speed, press the FAN button.

## FAN ONLY MODE

In this mode, only the fan of the air conditioner runs and circulates the air in the room. To activate this function mode, press the MODE button until the FAN indicator light comes on. In this function mode, the temperature cannot be set. Subsequently, set the desired fan speed by pressing the FAN button. When using FAN only mode, venting the exhaust hose to the outside is optional.

## OPERATION INSTRUCTIONS

### TIMER (DELAYED SWITCH ON / OFF) FUNCTION

This function mode enables a delayed switch ON or delayed switch OFF of the air conditioner. The time (hours) delay can be set, enabled and disabled.

### SETTING SWITCH OFF TIMER

With the air conditioner operating in any function mode, press the TIMER button. The TIMER OFF light will come on. Then set the desired time delay OFF hours by pressing the UP and DOWN buttons. The time increments are at 0.5 hour to up to 10 hours, followed by 1 hour increment up to 24 hours. When the delay time set has elapsed, the air conditioner switches off. To cancel the delayed switch off function, turn off the air conditioner or adjust the time setting to 0.0.

### SETTING DELAYED SWITCH ON TIMER

With the air conditioner is off, press the TIMER button. The TIMER ON light will come on. Then set the desired time delay ON hours by pressing the UP and DOWN buttons. The time increments are at 0.5 hour to up to 10 hours, followed by 1 hour increment up to 24 hours. When the delay time set has elapsed, the air conditioner switches on. To cancel the delayed switch on function, turn on the air conditioner or adjust the time setting to 0.0.

### I SENSE FUNCTION

The remote control serves as a remote thermostat allowing for the precise and comfortable temperature control. With this technology, an efficient temperature sensor is integrated in the remote control. To activate the I SENSE function, press I SENSE button on the remote control. Once this function is activated, the remote control will send the temperature signal to the air conditioner every 3 minutes interval until you press the I SENSE button again. The air conditioner will automatically cancel the I SENSE feature if it does not receive the signal during any 7 minutes interval.

*NOTE: The I SENSE feature is not available in DRY and FAN mode. Shifting the operating mode or turning off the unit will cancel the Follow Me feature automatically. The remote control needs to be within 26 feet reach of the indoor unit for the I SENSE mode to work appropriately.*

### SLEEP MODE

In this mode, the air conditioner gradually increases the set temperature in cooling mode, decreases the noise level and conserves energy. In Economy and cooling mode, the set temperature is increased by 1°C/ 2°F in the first 30 minutes. The temperature will then increase by another 1°C/ 2°F after an additional 30 minutes. This new temperature will remain the same for 7 hours. To activate this function mode, press the SLEEP button until the SLEEP indicator light comes on.

*NOTE: This feature is not available in FAN or DRY mode.*

### AUTO RESTART

In the event of a power outage, the air conditioner restarts at the previously set function mode and settings when power is restored.

### CONTROLLING THE AIR FLOW DIRECTION

The louvers can be controlled to Auto-Swing or in a fixed direction. To control the air flow direction by Auto-Swing, press the SWING button. To set the louvers in a fixed angle or direction, press SWING button while on Auto-Swing mode when desired angle is chosen.

### NOISE LEVEL

Portable air conditioners may make sounds that are not familiar to you. The sounds listed below are normal. Noise reflecting off hard surfaces such as a floor or wall can make the sounds seem louder than they actually are.

- The compressor may make a pulsating or high-pitched sound
- Water running from the evaporator to the water tank may make a splashing sound
- Refrigerant flowing may make a gurgling sound
- Fan sound may come from front and back air vents

### COMPRESSOR LOCK OUT

This portable air conditioner is optimized to operate in an ambient temperature of 64°F – 90°F. The compressor circuit has an automatic 3 minute time delayed start if the unit is turned off and on quickly. This prevents over-heating of the compressor and possible circuit breaker tripping.

## REMOTE CONTROL

The portable air conditioner can be switched on by the remote control. To transmit signals from the remote control to the air conditioner, point the front part of the remote handset towards the control panel on the air conditioner. Reception of the signal is confirmed by a beep. The maximum signal transmission distance is approximately 8 meters / 26 feet.

NOTE:

- Other appliances in the same room controlled by a remote control (TV, radio, stereo, etc.), may cause interferences
- Electronic and fluorescent lamps may interfere with the signal transmissions between the remote control and the air conditioner
- Remove the batteries if the remote control is not used for long periods

1	Mode indicator	Displays the current selected mode (Auto, Cool, Dry, Heat* or Fan)
2	Wireless indicator	Displays when the remote is turned on, and disappears when it is turned off
3	Timer On indicator	Displays when TIMER ON is set
4	Timer Off indicator	Displays when TIMER OFF is set
5	Swing indicator	Displays auto-swing feature is turned, and disappears when it is turned off
6	Temperature/Timer display (h)	Displays the set temperature or timer setting when using ON/ OFF functions "h (hours)" indicator is shown when timer settings are activated
7	Remote Control indicator	Displays when the remote is turned on and disappears when it is turned off
8	Temperature Scale indicator	Displays temperature scale Fahrenheit or Celsius
9	Lock settings indicator	Indicated all the current settings are locked
10	Sleep Feature indicator	Displays when SLEEP function is activated
11	I Sense Feature indicator	Displays when I SENSE function is activated
12	Fan Speed indicator	Displays the current selected fan speed
13	Up button	Increases set temperature/time
14	Down button	Decreases set temperature/time
15	Mode button	Controls the function modes: Auto, Cool, Dry, Heat* and Fan <i>*only for ARC-1230WNH</i>
16	Power button	Turns the unit On and Off
17	Fan Speed button	Controls the fan speeds: Auto, High, Medium, or Low (Continuous mode cannot be set using the remote control)
18	Swing Feature button	Press to stop or start louver auto-swing feature
19	Sleep Feature button	Starts or stops louver movement and set louver angle
20	Timer ON button	Enables the Timer On
21	I Sense Feature button	Press to initiate I SENSE feature
22	Lock settings button	Press I SENSE and TIMER OFF buttons to lock current settings
23	Timer OFF button	Enables the Timer Off
24	LED Display button	Press this button to turn on and turn off the display on the indoor unit
25	Temperature Scale button	Press to change Temperature Scale (Fahrenheit   Celsius)

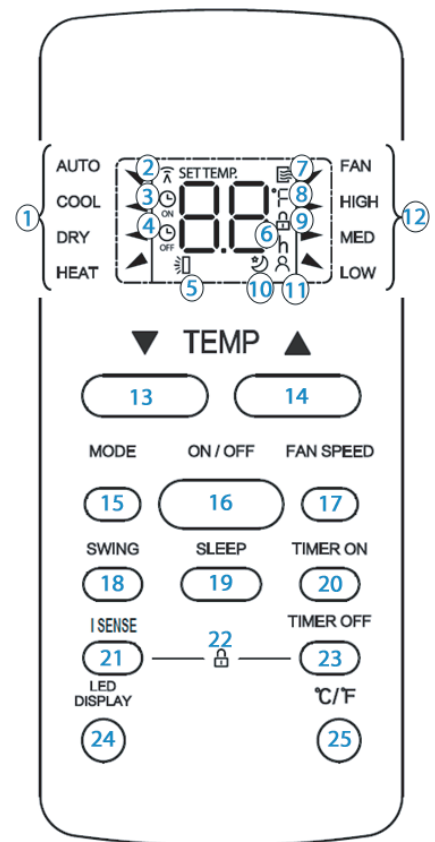

## REMOTE CONTROL

### REPLACING THE REMOTE BATTERIES

This remote control comes with two AAA batteries. Place the batteries in the remote control before use.

1. Slide the back cover from the remote downward to expose the battery compartment.
2. Insert the batteries, ensure to match the (+) and (-) symbols on the ends of the batteries with the symbols inside the battery compartment.
3. Slide the battery cover back into place.

#### Notes:

- The air conditioner will not respond if curtains, doors or other materials block the signal from the remote control to the unit.
- Prevent any liquid from contact with the remote control. Do not expose the remote control to direct sunlight or heat.
- If the infrared signal receiver on the indoor unit is exposed to direct sunlight, the air conditioner may not function properly. Use curtains to prevent the sunlight from falling on the receiver.
- Do not mix old and new batteries or batteries of different types.
- Do not leave the batteries in the remote control if it is not going to be used for more than two months.

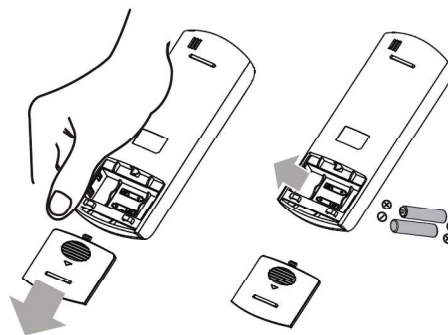

## CARE AND MAINTENANCE

### SAFETY PRECAUTIONS

- Always unplug the unit before cleaning or servicing.
- DO NOT use flammable liquids or chemicals to clean the unit.
- DO NOT wash the unit under running water. Doing so causes electrical danger.
- DO NOT operate the portable air conditioner if the power supply was damaged during cleaning. A damaged power cord must be replaced with a new cord. Contact Whynter Customer Support for more information.

### WATER DRAINAGE

When the internal drain pan becomes full the appliance will beep 8 times and the digital display will show error code P1. The air conditioning or dehumidifying action will stop but the fan may continue to operate. Ensure that the appliance is turned off and unplugged and that it is close to a floor drain before setting up any drain option.

#### A. Drain Plug

Remove the drain plug and allow the water to completely drain. Replace the bottom drain plug, pressing firmly to ensure a tight fit and no leaks.

#### B. Continuous Gravity Drain

During dry mode, install continuous drain option so that the appliance will automatically drain collected water. Remove the upper drain plug and attach the drain hose that was provided with the appliance. Place the open end of the drain hose over the receptacle that the appliance will drain into; this could be a basement floor drain, a sink or similar. Ensure that there are no kinks or bends in the drain hose and that it goes straight down toward the floor. The continuous drain is activated by gravity only. If the hose is not positioned directly downwards, water will not drain correctly.

#### C. Heat pump drainage (for ARC-1230WNH only)

This unit has a condensate pump feature that can pump out (and up) water through the included drain hose for continuous water removal during HEAT Mode. Remove the heat pump drain plug from the back of the unit and install the drain hose. Place the open end of the hose to a drain area.

**NOTE:** The condensate pump will only engage during Heat mode and will not work in any other modes. Pump drain hose is required to be installed when using the portable air conditioner in Heat Mode.

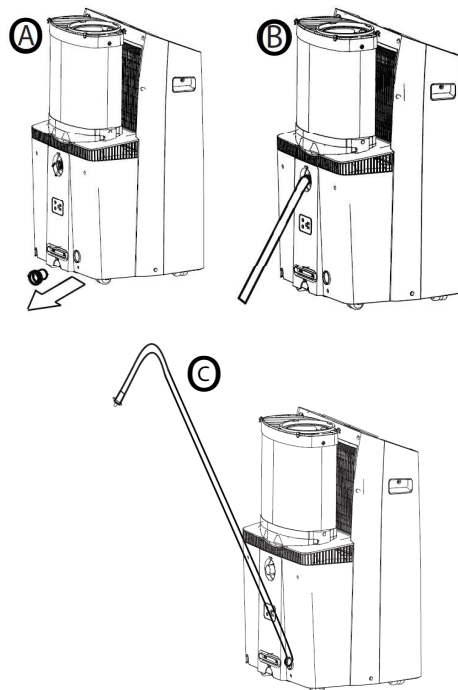



## CARE AND MAINTENANCE

### UNIT CLEANING

#### CLEANING

- Unplug the appliance before cleaning or servicing.
- Clean the cabinet with a lukewarm damp cloth and neutral detergent. Dry the cabinet with a lint-free dry cloth.
- Do not use gasoline, paint thinner or other chemicals to clean the appliance.
- Do not wash the appliance directly under a tap or using a hose. It may cause electrical damage.

#### AIR FILTERS

The air filter should be cleaned every two weeks to ensure efficient performance. In households with animals, the air filters may need to be cleaned more often and the external grills may need to be wiped to prevent blocked air flow.

To access the filter:

1. Switch off the air conditioner.
2. Hold the exhaust hose, push it backward slightly and then lift it up.
3. Remove the filter from the unit.
4. Use a vacuum cleaner or tap lightly to remove loose dust and dirt.
5. Rinse the filter thoroughly under warm running water (no hotter than 100° F.)
6. Dry thoroughly before re-inserting the filter.

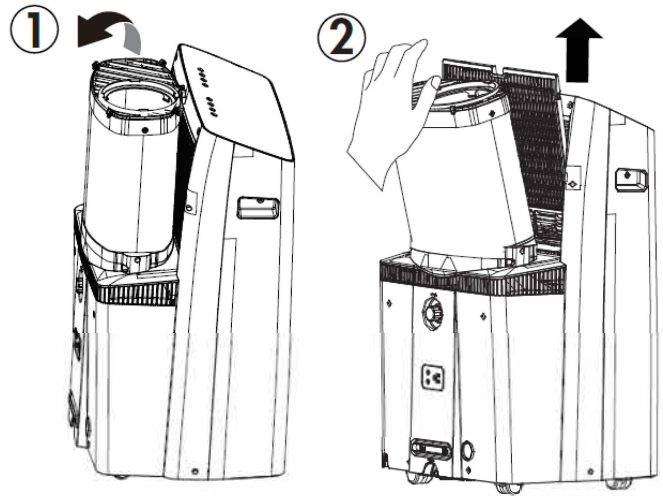

#### LONG-TERM STORAGE

1. Drain all water from the appliance.
2. Run the appliance on Fan mode for half a day in a warm room to dry the inside of the appliance and prevent mold formation.
3. Turn off the appliance and unplug it, wrap the cord and bundle it with tape.
4. Remove the batteries from the remote control.
5. Clean the air filters and reinstall them.
6. Store the appliance in a cool, dark place. Prolonged exposure to direct sunlight or extreme heat can shorten the lifespan of the appliance.

#### DISPOSAL

This appliance should not be treated as regular household waste. Check for local regulatory compliance regarding the approved and safe disposal of this appliance.

#### ERROR CODES

P1 - water tray is full - attach drain hose and drain excess water

If any other error code appears on the display, unplug the air conditioner and allow it to sit undisturbed for 5 minutes. If the error code persists when the unit is plugged back in, please contact Whynter Customer Support.

## TROUBLESHOOTING

Many common portable air conditioner problems are easily resolved. Try the troubleshooting suggestions below to see if the problems can be resolved before having to contact the service department.

PROBLEM	POSSIBLE CAUSES	SOLUTIONS
The portable air conditioner does not turn on	<ul style="list-style-type: none"> <li>• Power failure / outage</li> <li>• The automatic switch, line fuse, or breaker has been tripped</li> <li>• The power supply voltage is too low</li> <li>• The power cord is damaged</li> <li>• The L.C.D.I. power plug for the unit is tripped</li> <li>• The internal water reservoir is full and 'P1" appears on display</li> </ul>	<ul style="list-style-type: none"> <li>• Restore the power supply</li> <li>• Flip the switch / change the fuse / turn the breaker back on. Also note that you may have too many appliances drawing power on one circuit, you may need to move the other appliances to another circuit</li> <li>• Move the unit onto another circuit with the correct voltage</li> <li>• Call for service. Only authorized personnel should replace damaged power cord or power plug</li> <li>• Press the Reset button on the L.C.D.I. power plug</li> <li>• Drain water from the air conditioner</li> <li>• Possible loose internal connection.</li> <li>• Please contact Whynter for service.</li> </ul>
The unit turns on but the compressor does not turn on (the fan runs but the unit is not cooling)	<ul style="list-style-type: none"> <li>• The room temperature is outside of the operational tolerances of the unit</li> <li>• The Cooling mode is not on</li> <li>• The compressor has not turned on yet because of its time delay</li> <li>• The set temperature is too high</li> <li>• The internal water reservoir is full and 'P1" appears on display</li> </ul>	<ul style="list-style-type: none"> <li>• This unit is designed to work in ambient temperatures of 63°F to 90°F.</li> <li>• Press the MODE button until the COOL light is shown on the display.</li> <li>• Give the compressor 3 minutes to turn on after the Cooling mode has been selected.</li> <li>• Set the air conditioner to a lower temperature.</li> <li>• It is recommended to set the temperature to at least 5°F of the ambient temperature.</li> <li>• Either manually drain the water by removing the drain plug or allow the unit to exhaust the water itself by running the fan only mode. Then cooling will resume.</li> <li>• Possible loose internal connection.</li> <li>• Please contact Whynter for service.</li> </ul>
The air coming out of the unit is not very cold, or the airflow volume is weak	<ul style="list-style-type: none"> <li>• The filters are dirty or obstructed</li> <li>• The air intake or exhaust is obstructed</li> <li>• The unit is set in DRY or FAN mode</li> <li>• The unit is set to low fan speed</li> </ul>	<ul style="list-style-type: none"> <li>• Clean the air filters</li> <li>• Make sure there is at least 20" of clearance from the air intake. Make the length of the exhaust hose is as short as possible</li> <li>• Set the unit to the cooling mode</li> <li>• Set the unit to a higher fan speed</li> </ul>

## TROUBLESHOOTING

Many common portable air conditioner problems are easily resolved. Try the troubleshooting suggestions below to see if the problems can be resolved before having to contact the service department.

PROBLEM	POSSIBLE CAUSES	SOLUTIONS
The unit has worked for a long time, but the room is not cold enough	<ul style="list-style-type: none"> <li>• Windows or doors are open</li> <li>• There are too many people in the room</li> <li>• There is direct sunshine into the room</li> <li>• The room is a kitchen or with many heat producing appliances</li> <li>• There is a server in the room</li> <li>• The room is too large</li> </ul>	<ul style="list-style-type: none"> <li>• Close all windows and doors</li> <li>• You may need additional cooling or another air conditioner.</li> <li>• Close curtains or blinds and try to minimize the amount of direct sunlight into the room.</li> <li>• You may need additional cooling or another air conditioner.</li> </ul>
The unit is very noisy	<ul style="list-style-type: none"> <li>• The unit is not level</li> <li>• The surface underneath the unit is uneven</li> <li>• Low power voltage</li> </ul>	<ul style="list-style-type: none"> <li>• Make sure the unit is on hard, level and stable surface.</li> <li>• Move the unit to a location with a level and hard floor.</li> <li>• Make sure the wall outlet and support the required power consumption of the air conditioner and do not use an extension cord.</li> </ul>
The unit leaks water	<ul style="list-style-type: none"> <li>• The unit is tilted or not leveled</li> <li>• The water tank is full</li> </ul>	<ul style="list-style-type: none"> <li>• Make use the unit is leveled</li> <li>• Drain water from the drain plug at the back of the air conditioner</li> </ul>
Fan speed cannot be changed	<ul style="list-style-type: none"> <li>• Fan speed differences are not very noticeable</li> </ul>	<ul style="list-style-type: none"> <li>• The fan speed difference is not very noticeable when the compressor is on. Try setting the unit to Fan only mode, you should be able to hear the difference between high and low fan speed settings.</li> </ul>

# **ONE YEAR LIMITED PARTS WARRANTY**

## **THREE YEAR WARRANTY ON COMPRESSOR**

This WHYNTER product is warranted to the original owner, purchased from an authorized Whynter dealer within the 48 U.S. continental states, for one year from the original purchase date against defects in material and workmanship under normal residential usage. Should your WHYNTER product prove defective within one year from the date of purchase, contact Whynter's Customer Support team with the serial number and proof of purchase to make a warranty claim. A Return Authorization number must be issued before returning any parts or products. Parts or products received without a Whynter issued Return Authorization number will be refused. Under this warranty, Whynter will repair or replace any parts found defective with new or remanufactured parts or exchange the defective product with a new, refurbished, or remanufactured product at our discretion. All defective products and parts covered by this warranty will be repaired or replaced on a mail-in basis to Whynter's Service Center. This warranty is not transferable. After the expiration of the warranty, the cost of labor and parts will be the responsibility of the original owner.

After two months to one year, the customer will be responsible for the return freight cost to Whynter's Service Center. Please package the product carefully in its original packaging to avoid damage in transit. Whynter is not responsible for damage resulting from shipper mishandling or improper packaging. Please retain the original box and packaging materials.

### **THIS WARRANTY DOES NOT COVER:**

- Acts of God, such as fire, flood, hurricanes, earthquakes and tornadoes.
- Improper power supply such as power surge, low voltage, defective household wiring or inadequate fuses.
- Use in commercial or industrial applications.
- Damage, accidental or otherwise, to the product while in the possession of a consumer not caused by a defect in material or workmanship.
- Damage caused by consumer misuse, tampering, lack of maintenance or failure to follow the care and special handling provisions in the instructions.
- Damage to the finish of the case, or other appearance parts caused by wear.
- Damage caused by repairs or alterations to the product by anyone other than authorized by the manufacturer.
- Removal, Replacement Packaging, Freight and Insurance cost for the warranty service.
- Products sold AS IS or from an unauthorized reseller.
- Products that have had their serial numbers removed or defaced.

### ***DISCLAIMER OF IMPLIED WARRANTIES; LIMITATION OF REMEDIES***

*CUSTOMER'S SOLE AND EXCLUSIVE REMEDY UNDER THIS LIMITED WARRANTY SHALL BE PRODUCT REPAIR OR REPLACEMENT AS PROVIDED HEREIN. CLAIMS BASED ON IMPLIED WARRANTIES, INCLUDING WARRANTIES OF MERCHANTABILITY OR FITNESS FOR A PARTICULAR PURPOSE, ARE LIMITED TO ONE YEAR OR THE SHORTEST PERIOD ALLOWED BY LAW, BUT NOT LESS THAN ONE YEAR. WHYNTER SHALL NOT BE LIABLE FOR CONSEQUENTIAL OR INCIDENTAL DAMAGES SUCH AS PROPERTY DAMAGE AND INCIDENTAL EXPENSES RESULTING FROM ANY BREACH OF THIS WRITTEN LIMITED WARRANTY OR ANY IMPLIED WARRANTY. SOME STATES AND PROVINCES DO NOT ALLOW THE EXCLUSION OR LIMITATION OF INCIDENTAL OR CONSEQUENTIAL DAMAGES, OR LIMITATIONS ON THE DURATION OF IMPLIED WARRANTIES, SO THESE LIMITATIONS OR EXCLUSIONS MAY NOT APPLY TO YOU. THIS WRITTEN WARRANTY GIVES YOU SPECIFIC LEGAL RIGHTS. YOU MAY ALSO HAVE OTHER RIGHTS THAT VARY FROM STATE TO STATE.*

To obtain service or information, contact  
Whynter LLC via email at [support@whynter.com](mailto:support@whynter.com) or call  
866-WHYNTER.

Product contents and specifications may change without notice.

Copyright © 2021  
WWW.WHYNTER.COM