



MIG155Gsv



Operator's Manual

LINLONG LIMITED
www.weldpro.com



Introduction

Thank you for purchasing the Weldpro MIG 155Gsv welder. This welder is designed and built using the very best quality components to afford a great welding experience and great performance.

This manual contains the description of the hardware and the operating instructions of the equipment. For your safety and that of others, please read this manual carefully.

Attention

Pay attention to the words following the signs below.

Sign	Description
 DANGER	The word following this sign means that there is great potential danger, which may cause a major accident, damage or even death, if the instructions are not followed.
 WARNING	The word following this sign means that there is some potential danger, which may cause bodily injury or property damage, if the instructions are not followed.
 ATTENTION	The word following this sign means that there is potential risk, which may cause malfunctions and/or breakdowns, if the instructions are not followed.

Edition

The contents of this manual are updated regularly in order to include all product updates. The manual is to be used solely as a user's guide, except where indicated otherwise. No warranties of any kind, whether expressed or implied are made in relation to the information, descriptions, suggestions or any other content of the manual.

The images of this manual are for reference only. If there is any inconsistency between the image and the actual product, the actual product will govern.

CONTENTS









- 1 SAFETY WARNING..... 5
- 2 PRODUCT DESCRIPTION..... 9
- 3 TWO YEAR WARRANTY..... 10
- 4 TECHNICAL PARAMETERS..... 11
- 5 GENERAL WELDING FACTS..... 12
- 6 ELECTRICAL VOLTAGE..... 13
- 7 INSTALLATION..... 14
- 8 OPERATION..... 18
- 9 TROUBLESHOOTING..... 23

SAFETY WARNING

The safety notes contained in this manual are to ensure the correct use of the machinery and to prevent injury to the user or other persons.

The welding machine was designed and manufactured with safety in mind. Please refer to the safety warning contained in the manual to avoid accidents.

The incorrect use of the equipment may cause different injuries, as described below. Please read the user manual carefully to avoid these kind of injuries.

Sign	Description
	<ul style="list-style-type: none"> Any contact with the electric parts may cause fatal electric shock or burns.
	<ul style="list-style-type: none"> The gases and fumes are harmful to health. Operation in confined spaces may cause simple asphyxiation.
	<ul style="list-style-type: none"> Sparks and hot workpieces after welding may cause fire. Incorrectly connected cables may cause fire. The incomplete connection of the workpiece side circuit may cause fire. Never weld in the presence of tinder, as it may cause explosion. Never weld airtight containers such as valves, pipes etc., as they may break.
	<ul style="list-style-type: none"> The arc ray may cause eye inflammation and / or skin burns. Sparks and residue may cause eye and skin burns.
	<ul style="list-style-type: none"> Toppling the gas cylinder may cause physical injuries. The misuse of gas cylinders may lead to high-pressure gas leakage and may cause personal injuries.
	<ul style="list-style-type: none"> Keep fingers, hair, clothes etc. away from moving parts, such as the fan.
	<ul style="list-style-type: none"> Wire shooting out of the welding torch may stab your eyes, face or other exposed body parts.
	<ul style="list-style-type: none"> Never stand in front of or under the suspension hook, as it may fail and cause personal injuries.



DANGER Please observe the following rules to avoid serious accidents

- Never use the equipment for purposes other than welding.
- Follow related regulations regarding the characteristics of the power source, choice of place, usage of high-pressure gas, storage, configuration, safe-keeping of the workpiece after welding and disposal of waste, etc.
- Non-essential personnel shall not enter the welding area.
- Persons using pacemaker are not allowed near the welding machine or welding area without doctor's permission. The magnetism created by energizing the welding machine may have a negative effect on the pacemaker.
- The installation, operation, inspection and maintenance of the equipment must be carried out by authorized personnel.
- For your safety, you must understand the contents of the user's manual.



DANGER Please observe the following rules to avoid electric shock

- Keep away from any electrical parts.
- The machine and workpiece shall be grounded by authorized personnel.
- Cut off the power before installation or inspection, and restart it 5 minutes after finishing that activity. The capacitor is a rechargeable device. Please ensure it has no voltage before starting again even if the power source is cut off.
- Never use wire with inadequate wire gauge, damaged insulation sleeve or exposed conductor.
- Do ensure the proper isolation of wire connections.
- Never use the device when the enclosure is removed.
- Never use broken or wet insulation gloves.
- Welding screens must be used when working in overhead position.
- Check and maintain the equipment regularly. Do not use the equipment until the faulty parts are fixed.
- Turn off the power when not in use.
- Follow the related national and local standards and regulations when using the AC welding machine in confined spaces or overhead position.



DANGER Please observe the following instructions to avoid fire, explosions, etc.

- Remove combustible materials from the welding area.
- Keep away from any combustible materials while welding.
- After welding, keep the hot workpiece away from flammable gases.
- Remove all combustible materials when welding in a patio, on the ground or on a wall.
- The work lead of the base metal should be as close to the welding place as possible.
- Never weld installations with gas pipes or airtight valves.
- Keep a fire extinguisher close to the welding area to prevent fire.



WARNING The gases and fumes are hazardous to health, please wear personal protective equipment according to regulations

- Wear exhaust equipment and respiratory protective equipment to prevent gas poisoning or choke.
- Use suggested exhaust ventilation system and respiratory protective equipment to prevent injuries or poisoning by gas or dust.
- To prevent oxygen deficiency, air out the gas filled space full of CO₂ and argon on the bottom, when operating in trunks, boilers, cabins, etc.
- Request a supervisor's inspection when operating in confined spaces. Air the room and wear respiratory protective equipment.
- Never operate in degreasing, washing or spraying spaces.
- Use respiratory protective equipment while welding armored steel, as this produces poisonous dust and gases.



WARNING The welding arc, sparks, residues and noise are hazardous to health, please wear personal protective equipment

- Eye protection against welding arc is recommended when welding or supervising welding.
- Please wear safety goggles.
- Welder's gloves, welder's goggles, long sleeve clothes, leather apron, and other standard personal protective equipment must be worn during the welding operation.
- A screen to protect other people against the welding arc must be set in the welding area.



WARNING Please observe the following notes to avoid toppling or breaking the gas cylinder

- Use the gas cylinder correctly.
- Use the built-in or recommended gas regulator.
- Read the manual of the gas regulator carefully before using it, and pay attention to the safety notes.
- Secure the gas cylinder with appropriate holder and other related parts.
- Never expose the cylinder to high temperature or direct sunlight.
- Keep your face away from the gas cylinder's valve when opening it.
- Put on the cap when the cylinder is not in use.
- Never put the welding torch on the gas cylinder. The electrode must not touch the gas cylinder.



WARNING Any contact with the rotating parts will cause injury. Please note the following:

- Never use the machine when the enclosure is off.
- The installation, operation, inspection and maintenance of the equipment must be carried out by authorized personnel.
- Keep fingers, hair, clothes etc. away from moving parts, such as the fan.



WARNING The end of the wire may cause personal injuries. Please note the following:

- Never look into the conduction hole when checking if the wire feed is normal, as wire shooting out may stab your eyes and face.
- Keep your eyes, face or other uncovered body parts away from the end of the welding torch when feeding the wire manually or when pressing the switch.



ATTENTION For better work efficiency and power source maintenance, please note the following:

- Take precautions to prevent toppling.
- Never use welding equipment to unfreeze a pipe.
- Lift the power source from side when using a forklift to avoid toppling.
- When using the crane to lift, tie the rope to the ears with an angle smaller than 15° respect to the vertical direction.
- When lifting the welding machine equipped with gas cylinder and wire feeder, disconnect it from the power source and ensure that the machine is in horizontal position. Secure the gas cylinder with a belt or chain when moving it to avoid personal injuries.
- Ensure stability and insulation when lifting the wire feeder by the suspension hook for welding.



ATTENTION Pay attention to electromagnetic interference

- You may need to take extra preventive measures when the equipment is used in a particular location.
- Before installation, assess the potential issues with the electromagnetism in the welding environment as follows:
 - a) Proximity of upper and lower parts of the welding equipment to other nearby power cables, control cables, signal cables and phone cables.
 - b) Wireless radiation-emitting products such as devices emitting and receiving TV signals.
 - c) Computers and other control equipment.
 - d) Protection equipment, etc. equipment to supervise industrial equipment.
 - e) Health of personnel affected, such as personnel using pacemaker or audiphones.
 - f) Instruments for adjusting and measuring instruments.
 - g) Anti-disturb capability of other equipment used. Users should ensure the compatibility of the equipment with the environment, which may require extra preventive measures.
 - h) Practical conditions of the welding and other activities.
- Users should observe the following to decrease radiation interference.
 - a) Connect the welding equipment to the power supply lines by the power supply cable.
 - b) Maintain the welding equipment regularly.
 - c) The cables should be short enough to stay close to each other and to the ground.
 - d) Ensure the safety of all the metal parts to be welded and other parts nearby.
 - e) The workpiece should be properly grounded.
 - f) Shield or protect all other cables and equipment to minimize the effect of possible disturbances. In some special cases, the welding equipment may need to be completely shielded.
- Users are responsible for the interference due to welding.

PRODUCT DESCRIPTION

This welding machine is equipped with the world's most advanced inverter technology.

The inverter's working principle is that the 60Hz power line frequency is transformed to direct current and inverted to a high frequency using a high power IGBT device. After that, a voltage drop is generated and it is transformed to a to high-current DC using the Pulse Width Modulation (PWM) technology. Using the power inverter technology, the volume and the weight is substantially reduced and the conversion efficiency is increased by 30%.

The MIG155GSv is a self-shielding welding machine that can be used for MIG as well as for flux-cored arc welding. It is equipped with a unique electrical reactor, which can precisely control the short-circuit transfer and mixed transfer modes, this way it shows better performance than other machines. Compared with welding machines using silicone controlled rectifier and hot tapping, our products have the following advantages: stable wire feed rate, portable, energy saving, free of electromagnetic noise. Besides, our products spatter less, easier arc starting, deep welding pool, high duty cycle, etc.

This machine features a design which has the following advantages: high efficiency, power saving, etc. It is especially suitable for private users who wish to work with different metals using different techniques.

Thank you for choosing our product. Please feel free to share your valuable suggestions with us; we are continuously working on improving our products and services.



WARNING

The machine is mainly used for industrial purposes. It causes radio interference when used indoor. Users must take preventative measures.

TWO YEAR WARRANTY

WELDPRO Warranty and Return Terms
Welders and Plasma Cutters

All Weldpro welders and plasma cutters are covered under the following specific terms of warranty. All welders and plasma cutters are warranted to the original purchaser only, when purchased through an authorized seller of Weldpro products for a period of two (2) years from the date of purchase, to be free of manufacturers defect or failure. Proof of purchase and date of purchase paperwork will be required by Weldpro at the time of the claim.

Extended warranty coverage may be available for Weldpro welders and plasma cutters at an additional cost. Always check with Weldpro.

The Weldpro warranty is limited to defects, malfunctions or failure of the equipment to operate properly based specifically and solely from manufacturer defects. Any malfunctions from improper use, lack of maintenance, incorrect or insufficient source supply power to the units, shipping damage, and similar failures not related to specific manufacturers defect will not be honored.

Weldpro will not be responsible in the event of a product failure, for lost time in operation or use of said product. Rather it will honor solely the product itself only.

Further, the warranty will cover the repair or replacement of the unit in question for the term of the warranty with either a new or a refurbished unit, or in some cases replacement parts of the same model, at the discretion of Weldpro. As a term of the Weldpro warranty, if and when applicable, individual parts are needed, they may be supplied to the customer rather than replacing the entire unit. Situations like this may include, but are not limited to items such as foot pedals, torches, mig wire rollers, feed spools, or any other item Weldpro deems more practical to supply individually.

Weldpro will provide free shipping return of the damaged product due to manufacturers defect for the first 30 days of the warranty term if shipping is within the lower 48 United States. Customers outside this area must check with Weldpro for further shipping instructions. Failures after the initial 30-day period, and due to manufacturers defect, may not enjoy free return shipping.

If it is determined when the product is returned to Weldpro that there is no malfunction, or that the assumed malfunction by the customer was user error, Weldpro may request a shipping fee refund prior to the return of the item to the customer.

Prior to returning any item thought to be malfunctioning or damaged due to manufacturers defect, customers are required to contact Weldpro first, to explain the failure and to obtain a Return Merchandise Authorization number, or the item may not be covered under the terms of this warranty.

Weldpro ships in the USA from third party shippers such as, but not limited to UPS, FedEx, and the USPS. Weldpro is not responsible for damage that occurs during shipping. It is the customer's responsibility to check the item at the time of delivery. If a customer receives an item damaged, they must immediately contact both Weldpro and the shipper to document and report the damage as soon as possible, and in no circumstances later than 48 hours after delivery. All shipping and delivery dates are tracked for arrival. Weldpro may require photo image of the damage at their discretion.

Returned items within the first 30 days. Undamaged items in good working condition may be returned within the first 30 days of purchase. In such a case, these items are not eligible for the free return shipping policy associated with items that have manufacturers defects. A restocking fee will be charged for said return of up to 25% on any item returned with a valid RMA number that are undamaged and not covered or subject under the terms of this warranty. The amount of the restocking fee is solely at the discretion of Weldpro and based on the condition of the returned item and its accessory parts and packaging. Further, should Weldpro receive an item in good working condition that has sustained physical damage, Weldpro has the right to refuse acceptance of said returned item completely, and the customer will be responsible for return shipping of the product to them.

Weldpro does not imply or suggest any interpretation of the above warranty beyond what is stated in this print of its terms.

Weldpro is not responsible for injury due to improper use of the equipment or failure to heed all of the safety precautions associated with the dangers of welding or cutting metals.

The terms and conditions of the Weldpro warranty are subject to change without notice. Be sure to check the terms of the Weldpro warranty prior to your purchase.

TECHNICAL PARAMETERS

Model	MIG155Gsv	
Parameters		
Supply voltage (V)	1 phase 115V±15%	1 phase 230V±15%
Frequency (Hz)	60	
Rated input current (A)	MIG: 35.7 MMA: 40	MIG: 25.4 MMA: 26.7
No-load voltage (V)	59	
Output current (A)	MIG: 30-120 MMA: 30-110	MIG: 30-155 MMA: 30-140
Output voltage (V)	MIG: 15.5-20 MMA: 20.8-24.4	MIG: 15.5-22 MMA: 21.2-25.6
Duty cycle (%)	MIG: 30%120A 100%80A	MMA: 30%110A 100%80A
	MIG: 30%155A 100%100A	MMA: 30%140A 100%100A
Power factor	≥0.73	
Efficiency (%)	≥80	
Wire speed (ft/min)	6.6-39.4	
Post flow (s)	1	
Wire diameter (in)	MIG: .023-.030 Flux-cored: 0.30-0.40	
Appropriate thickness	22ga.-8ga.	
Housing protection class	Ip21	
Insulation class	F	
Cooling method	Fan-cooled	
Weight (lb)	35.7	
Dimensions (in)	22.4x11.6x20.7	

GENERAL WELDING FACTS

Unlike soldering or brazing, welding is the process of fusing two pieces of metal together to create a permanent union. In order to do so, there are many different types of welding. Most all the popular methods of welding require the weld area to be protected in one way or another from the atmosphere around the weld while the weld is being performed. This is done by various means in order to prevent contamination of the weld, which would result in a very poor quality product that lacked not only appearance, but fusion. The weld would be full of porosity, and would be too weak to be effective in joining the work metals. Shielding the weld area during welding is very important to a good weld.

Three of the most popular types of welding are offered with the MIG155Gsv. They will be briefly described here.

The MIG155Gsv is capable of performing MIG welding, Flux Core welding, and MMA welding.

MIG welding refers to “Metal Inert Gas” welding, a process where solid metal wire is continuously fed through a torch cable while being shielded from the contamination of the atmosphere around the weld by a special shielding gas. Typically for MIG welding that shielding gas is a mix of Carbon Dioxide (CO₂) and Argon gas, usually in the percentage of 25% CO₂ and 75% Argon. It is the cleanest, smoke free of the three weld types.

Flux Core welding, while very similar to MIG welding does not require any shielding gas to be added to the process. This is because Flux Core welding by definition uses a hollow wire, like a miniature straw and inside the wire, in its core, is a flux which creates it’s own gas that provides the shielding as it is heated in the weld. The heat of the welding process turns the flux into a gas that envelops the weld area, shielding it from the atmosphere.

MMA welding, (the third type) refers to Manual Metal Arc welding. This process is known by many other slang names such as “stick welding” or “arc welding”. This type welding is performed by placing a welding rod, or stick, into its holder and scratching its end to the metal to be welded which starts the electric arc. This type welding is also shielded from the atmosphere with a flux that is heated into a gas that surrounds the area being welded. This time however, the flux is coated on the outside of the consumable welding rod and no shielding gas tank is needed.

You can learn much more about each type welding as well as many others by simply searching the Internet.

ELECTRICAL VOLTAGE

Three additional considerations that need to be addressed and understood, with each type welding that your new MIG155Gsv is capable of producing are voltage, amperage and most importantly, Electrical Polarity.

Think of voltage as the electrical equivalent of water pressure, and amperage as the electrical equivalent of the flow rate of that water. With electricity, the more amperage the more heat and the more voltage, the more it pushes that heat through the electrical circuit.

There are basically two types of electric current. AC (alternating current) and DC (direct current). Direct current travels around its circuit in only one direction, while alternating current switches its direction back and forth in the circuit, in the USA, 60 times per second, or 60hz.

Your new MIG155Gsv is a DC (direct current welder) which means the current or (amperage) travels only in one direction. However, you have the ability to manually change that direction as needed for the choice of three welding types available with the MIG155Gsv.

You can choose from either “electrode positive” or “electrode negative”. Current in an electrical circuit travels from negative (or minus) to positive (or plus). Your electrode, is your torch gun, and your ground or work cable is what is attached to the metal being welded. You can chose to direct the current in the circuit toward or away from your welding torch end (electrode) as it travels in its circuit.

When welding using either the MIG style or MMA style of welding we want our polarity to be “electrode positive”. With current always traveling from negative to positive, (minus to plus). Doing so forces the current to travel toward our torch end which creates more heat at the consumable welding material being used in our torch, which produces a smoother better penetrating, more evenly melting weld.

When choosing Flux Core welding however, with the thinner more delicate flux core wire, we choose “electrode negative”. This changes the direction of the current helping to prevent the flux core wire from prematurely melting off from overheating by directing the current flow toward the work (or ground) and away from our electrode.

A little tidbit of information that might help prevent confusion. The direction of polarity is also sometimes referred to as DCEN or DCEP. Direct Current, Electrode Negative or, Direct Current Electrode Positive. And to further complicate their names, in addition, they also refer to the polarity as either Straight Polarity or Reverse Polarity, with electrode negative being straight polarity and electrode positive being reverse polarity.

Many welders in the USA have a funny way of remembering all this by oddly enough using two names of government officials. SENators and REPresentatives. Just remember SENator as Straight polarity Electrode Negative, and REPresentative as Reverse polarity Electrode Positive. Hope that little secret helps you remember!

INSTALLATION

Before connecting the machine, ensure that the power supply is cut off.

The welding machine is equipped with an input voltage compensation device. This device allows the machine to work without interruption when the input voltage fluctuates $\pm 10\%$ with respect to the nominal voltage.

When using a long cable in order to reduce the voltage drop, a cable with big cross section area is suggested. If the cable is too long, this will affect the arc starting performance and other system functions, we suggest to use the recommended length.

The MIG155Gsv can be used for both MIG (which is solid wire with shielding gas) and flux-cored arc welding. The welding torch is already connected to the machine. The welding machine is equipped with polarity converter that must be used when switching from solid wire to flux core. The coverter is a dinse wire connector which is located on the front of the welder between the plus and minus dinse connectors. When using solid wire with shielding gas, connect the dinse connector located between the plus and minus dinse plugins. to the positive side, and connect your work ground clamp to the minus connector. When welding with flux core wire, the ground cable must be connected to the plus terminal and the polarity conector for the torch must be connected to the minus dinse connector on the front of the machine.

Please see below the MIG welding installation diagram. In flux-cored arc welding mode the gas cylinder does not need to be connected, however the polarity must be reversed.

In MIG welding mode the machine uses 1.98lb wire spools.

- **Installation diagram in MIG mode**

With MIG welding you must be sure to have your tank of shielding gas ready. (usually 25% CO₂ and 75% Argon) also known as "C25".

Your welder comes supplied with only flux core wire, for MIG welding you will need solid wire. Depending on the thickness of your work either .025 for thinner metal, or .030 wire for thicker metal will work fine. Set your front panel to MIG welding.

Open the side of your MIG155Gsv to expose the setup mechanism ...

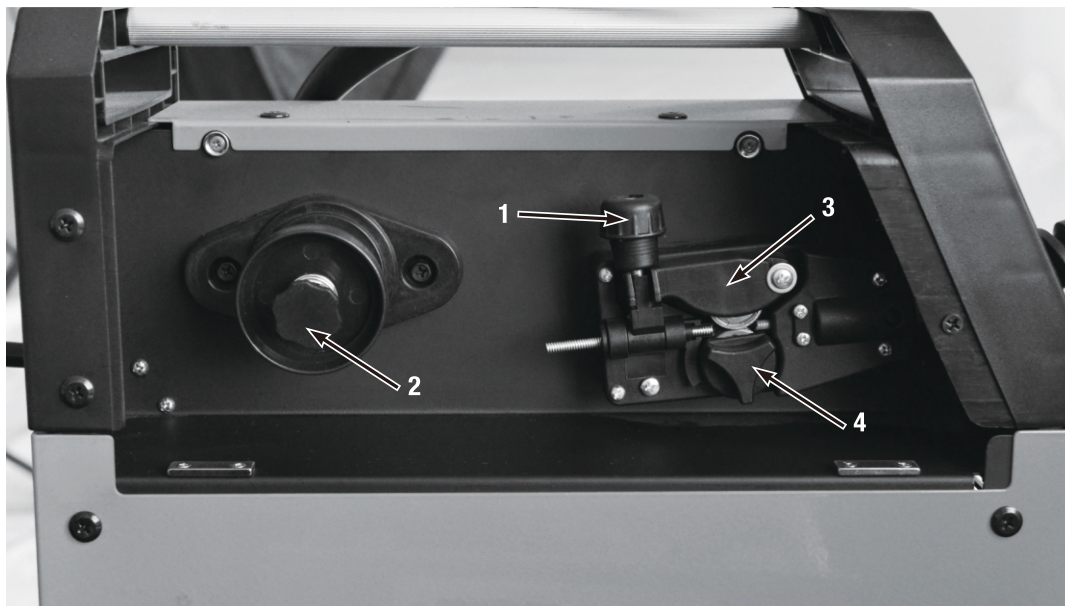

Roller tensioner. Tilt down the roller tensioner toward you, then lift and flip the tensioner assembly (3) up.

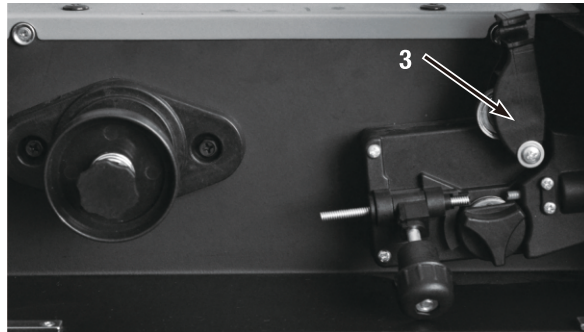

Twist the drive roller knob (4) counter clockwise to remove it. Slide out the lower drive wheel. The drive wheel will have markings on the front and back in two different sizes, in either millimeters or thousandths. A .06mm will handle 0.023 to 0.025 wire. Likewise a .08 will handle .030 wire. Be sure the correct size groove is in the outer position of the drive assembly to match the size of the wire you will be using and reinstall.

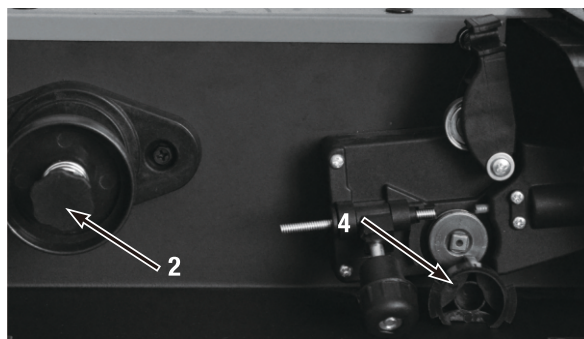

Remove the spool retainer (2) by turning it counter clockwise. Remove any plastic covering that may be on your new wire but do not un-secure the wire that is in the spool yet unless it interferes with the following test. If it does, just secure the loose wire end with painters tape or similar to the rest of the wire temporarily. Now, simply place your wire spool on the idler roller with the wire set up to be fed from the bottom as seen in the photo. Before un-securing the wire, replace the spool retainer and spring. Next roll the wire spool to be sure it turns freely with just a slight drag.

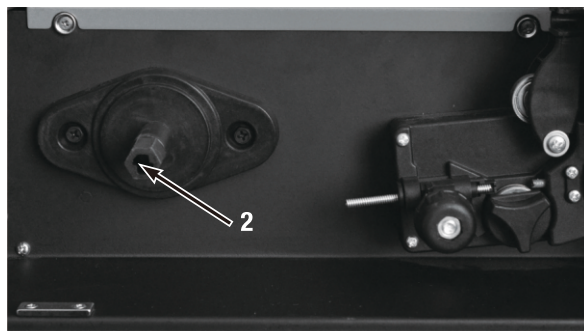

Note : a slight drag is necessary and should be provided correctly by the spool retainer spring. The drag will prevent the wire from continuing to spin and unwind itself each time you release your torch trigger. Should the drag be too tight, you may have to remove the sticker from your wire spool to provide more movement room.

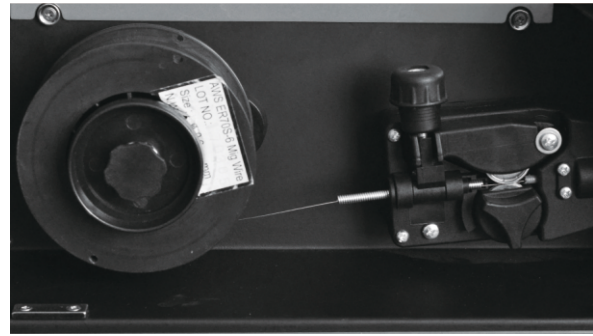
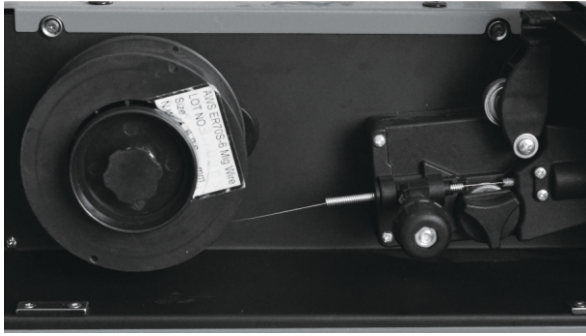

Once you are comfortable that there is a slight, even smooth drag on the welding wire spool, you may un-secure the wire from its shipping state, snip the bent end off and feed it through the spring opening on the bottom, over the drive wheel and into the torch cable. Feed it up into the cable a ways manually so it won't fall back out.

Connect your regulator to your CO2/Argon tank. Do not over tighten the regulator. They are made of brass and can be damaged. Once your regulator is connected to the shielding gas tank, open your gas tank slowly. If gas escapes from the regulator outlet, turn the knob on the regulator until it seals the gas from escaping. Once you have done that, open your gas tank valve all the way. This is an important step because the gas tank valve seals leakage at the full open valve, as well as the full closed valve position. Leaving the gas tank valve half open will risk losing gas unnecessarily.

Next, connect the supplied gas hose from the regulator outlet to the gas inlet on the backside of your MIG155Gsv welder. Snug tighten.

With your wheel drive tensioner (1) still open and loose, turn on your welder. After giving it a change to warm up, press your torch trigger. Wire will not feed since the tensioner is open, however now is the time to adjust your gas flow to the welder by turning your regulator until flow is about 20 to 25 CFH (cubic feet per hour). Release the trigger.

Finally, make sure your torch line is not kinked or bend severely. Position it in a smooth wide sweeping position so you can reach the side of your welder while holding the torch in your hand and not kinking it. Return the tensioner (1) to the closed position being sure the wire is riding in the wire size roller groove. Now, with it turned out to the loosest tension, press and hold your trigger. **WARNING .. DO NOT LOOK INTO THE TORCH END!** Wire may or may not begin to feed. Turn up your wire feed knob on the front of the machine, and give the wire time to travel along the cable. Watch the wire at the roller to see it feed. Slowly tighten down the tension on the drive wheel tensioner (1) until wire begins to feed. No more tension than smooth feeding is needed or desired. Once it has fed out of the torch end, release the trigger. Snip the wire approximately ¼ inch to ½ inch from the nozzle end.

Put on your protective gear, properly ground your work piece and have fun!

Don't forget to shut off your gas and your welder when you are done welding.

- **Installation diagram in Mig mode**

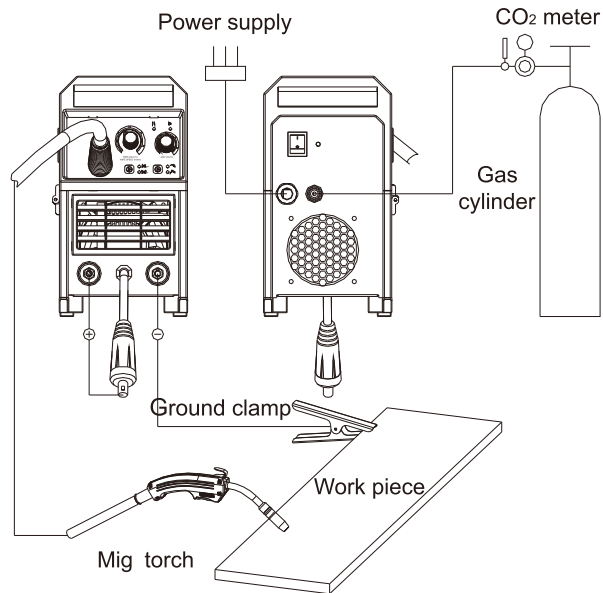

- **Installation diagram in MMA mode**

(AKA, Arc welding, Stick welding.) Switch over the front panel toggle to the MMA position. No gas is needed. Connect torch to “plus” and ground to “minus” to run your MMA in “reverse polarity, electrode positive. DCEP

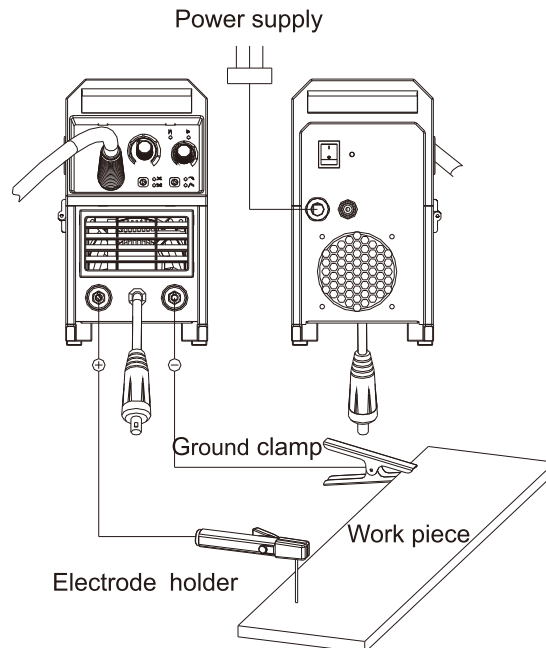

FLUX CORE WELDING .

Follow the above procedure, except shielding gas is not required nor does it have to be connected to your welder. Remember to change the polarity on your welding lead so that the ground clamp is connected to the “plus” dinse connector on your welder and the polarity lead which is located in the center, between the plus and minus dinse connectors, is connected to the “minus” plug. DCEN

OPERATION

4.1 Front panel layout

The values of the adjustment knob are indicated on the front panel of the machine. The pictures in this manual are for reference only. The actual product may be different.

- **Front panel**

1	Voltage adjustment knob
2	Power indicator light
3	Fault indicator
4	Current adjustment knob
5	MIG welding torch
6	Positive outlet
7	Polarity Reversing Switch
8	Negative outlet
9	2T/4T control switch
10	MMA/MIG control switch

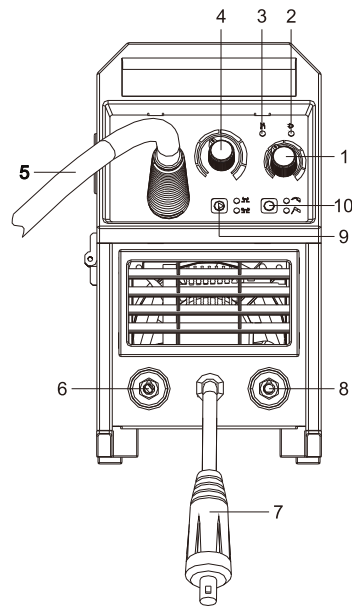

- **Back panel**

11	Power switch
12	Power supply outlet
13	Gas cylinder inlet connector

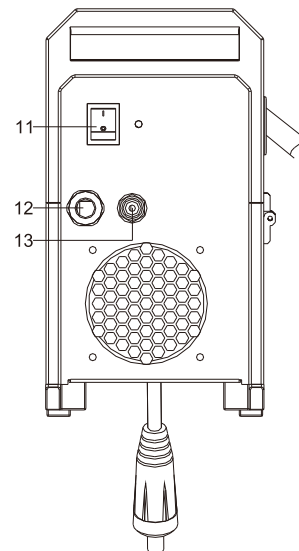

4.2 Operating instructions

- Turn on the power switch, the power indicator light comes up and the fan starts running.
- Set the welding current according to the requirements of the welding work.
- Usually, the necessary welding current for the electrode welding is as follows:

	Wire Type	Shielding Gas (20-30)CFR Flow Rate	Wire Diameter	24ga (0.61mm) V/A	22ga (0.8mm) V/A	20ga (1.0mm) V/A	17ga (1.5mm) V/A	14ga (2.0mm) V/A	1/8" (3.0mm) V/A	5/36" (4.0mm) V/A	1/16" (5.0mm) V/A	1/4" (6.0mm) V/A
	MIG	solid wire	75%Ar 25%CO ₂	0.6/.024"	15.0/40	15.7/50	16.5/65	18.5/90	20/115	20.7/130	-	-
0.8/.030"				-	16.0/50	16.5/65	17.5/80	19/110	20.5/140	22/160	-	-
1.0/.040"				-	-	17.0/65	18.0/85	19.5/105	21/145	22.5/170	23.5/200	25/220
100%CO ₂			0.6/.024"	15.6/40	16.5/50	17.3/65	19.2/100	21.5/115	21.6/130	-	-	-
			0.8/.030"	-	16.5/50	17.0/65	18.0/80	20.5/110	21.5/140	23/160	-	-
			1.0/.040"	-	-	17.5/65	18.5/85	20/105	21.5/145	23.5/170	24.5/200	26/220
Flux-cored		-	0.8/.030"	-	-	15.5/65	16.5/70	19/100	21.5/130	-	-	-
			1.0/.040"	-	-	-	16.5/70	19/100	22/135	23.5/165	24.5/200	-

	Material	Electrode Type	Wire Diameter	17ga Amps.	14ga Amps.	1/8" Amps.	5/36" Amps.	1/16" Amps.	1/4" Amps.	≥ 1/4" Amps.		
	MMA	Stainless steel, steel	Acid electrode	2.5	30	50	70	90	-	-	-	-
3.2				-	50	70	90	140	-	-	-	-
4				-	-	70	90	140	200	-	-	-
Cellulose electrode			2.5	-	65	80	100	-	-	-	-	-
			3.2	-	-	80	100	130	150	-	-	-

4.3 Welding environment and safety

- **Welding environment**

- a) The welding should be carried out in dry surroundings, with an air humidity level of maximum 80%.
- b) The temperature must be between 14 and 104 degrees Fahrenheit.
- c) Avoid using the equipment under direct sunlight and rain. Avoid any contact with water.
- d) Do not use the machine in environments polluted with dust or corrosive gases.

- **Safety**

Our machine is equipped with surge, overcurrent and overheat protection. In case the input voltage, the output current or the internal temperature of the machine exceeds the standard values, the machine stops automatically. The excessive use with, for example high voltage, may damage the machine. Please pay attention to the following points.

- a) Ensure adequate ventilation!**

The welding machines work with high current. Natural airflow is not sufficient to cool down the internal components. For this reason, the machines have fans to provide stable operation.

The exhaust shutter must never be blocked or covered. Keep a distance of 11.8" between the machine and other objects. Ensure a well ventilated work area to ensure the best possible performance and the longest possible lifetime.

- b) Never overload!**

Check the maximum nominal current (according to the Duty Cycle chosen). The welding current should never be higher than the nominal value. Excess workload may shorten the lifetime of the machine or damage the equipment.

- c) Avoid surging!**

The input voltage is indicated on the technical data sheet. The automatic voltage compensation circuit will prevent from exceeding the allowable range. If the input voltage is too high, that may damage components. Keep this in mind and take appropriate preventive measures.

- d) Never cut off the power supply arbitrarily**

If the operating time is longer than the Duty Cycle, the machine may suddenly enter protection mode and stop as the excessive heat activates the overheat protection. The red indicator light located on the front panel lights up. If this happens, don't cut off the power supply, as the fans continue working and cooling down the machine. Once the red light turns off the temperature is again within the allowable range.

4.4 Troubleshooting during welding

The below listed occurrences may happen due to the accessories used, the welding material, the environment or the power supply. Improve the working environment to prevent these issues.

- **Difficult arc starting. The arc is constantly interrupted: or poor performance in general.**

- a) Check if the grounding clamp is properly connected to the workpiece.
- b) Check if all connectors are connected properly.
- c) Be sure to check that the proper polarity is set for welding type.
- d) Check wire feed roller tension. Be sure it is not too tight.
- e) Check wire spool. Be sure tension is not too tight.
- f) When welding with solid wire, be sure your gas is turned properly.

- **The output current does not reach the nominal value:**

The deviations from the nominal supply voltage may cause that the output current does not match its pre-established value. When the supply voltage is lower than its nominal value, the maximum output current may be lower than its nominal value, too.

4.5 Daily maintenance and checking

- **Daily maintenance**

- Remove dust regularly with a dry compressed air. If the welding machine is used in an environment with heavy smoke and/or polluted air, the dust must be removed at least once a month.
- Revise the internal connections and ensure a perfect contact (especially plugs and sockets). Fasten any loose connections. If they are oxidized, remove it with sandpaper and connect again.
- Prevent water from entering the machine and the machine from getting wet. If so, air dry it. Measure the insulation with a megohmmeter to make sure it's safe to use the machine.
- If the machine is not in use for a prolonged period of time, put it in its original package and store it in a dry place.
- The wire feeder's electric carbon brush must be sharpened, and its wire guide must be cleaned after each 300 hours of operation. Rinse the speed reducer, apply 2# Molybdenum disulfide lubricant on the turbine, pivot rod and bearing.



WARNING

The power must be cut off completely before starting any repair or maintenance. Make sure that the power supply cable is disconnected before you open the housing.

1. Daily checking

WELDING TORCH		
Component	To check	Remarks
Air vent	Check if the torch is properly connected and if there are any deformations.	There may be an air leak
	Check if it produces splatter.	The welding torch might burn out (use spatter resistant materials)
Electric outlet	Check if the torch is properly connected.	The screw thread of the welding torch may be damaged.
	Check if the head is damaged and if the orifice of the outlet is blocked.	May cause unstable arc or block arc starting.

Wire supply tube	Check the size of the tube extension piece.	The tube must be at least .230". If the extension piece is too small, the arc is unstable.
	Check if the diameter of the wire matches the inner diameter of the tube.	May cause unstable arc. Use an adequate tube.
	Check the reel and the extension piece.	May result in poor wire supply and unstable arc. Change the tube.
	Check for blockage caused by dirt or wire residue.	May result in poor wire supply and unstable arc (clean the tube with kerosene or change it)
	Check if the wire supply tube is damaged or the O-ring is worn down.	1. The tube was damaged by the heat. Change it. 2. Change the O-ring.

CABLES

Component	To check	Remarks
Cable of the welding torch	<ul style="list-style-type: none"> • Check if the cable of the welding torch is bent too much. • Check if the mobile connector is well connected. 	<ol style="list-style-type: none"> 1. May cause poor wire supply. 2. If the cable is bended too much, the arc will be unstable
Output cable	<ul style="list-style-type: none"> • The insulation is worn down. • The cable connector is naked (damaged insulation) or loose (primary point between the power supply and the cable) 	<p>For your safety and to ensure a stable welding, select the appropriate method to carry out the inspection, according to the workplace.</p> <ul style="list-style-type: none"> • Standard daily inspection. • Thorough and deep inspection in set intervals.
Input cable	<ul style="list-style-type: none"> • Check if the power supply connector and the protective equipment are connected properly. • Check if the safety equipment is connected properly. • Check if the connector of the input cable is connected properly. • Ensure that the input cable is not worn down and that the conductor is not exposed. 	
Grounding cable	<ul style="list-style-type: none"> • Check if the ground cable connecting to the power supply is not broken and ensure that it's connected properly. • Check if the ground cable connecting to the workpiece is not broken and ensure that it's connected properly. 	Carry out daily inspection to extend the lifetime of the machine and to guarantee security.

TROUBLESHOOTING

Note : The following operations must be carried out by a qualified electrician with valid certifications. Before maintenance, you are suggested to contact a local dealer to verify said qualification.

Fault description	Measures to take
The power indicator light is off. The fan is not on. There is no welding output.	<ol style="list-style-type: none"> 1 Make sure that the air switch is closed. 2 Check if the power network works well. 3 One of the (four) heat variable resistors on the power supply panel is damaged. When this happens, the 24VDC general relay is open or the connectors are not connected properly. 4 The power supply panel (bottom board) is damaged. There is no 308VDC output. <ol style="list-style-type: none"> (1) The silicone bridge is broken or the silicon bridge connector is not connected properly. (2) The power supply panel is burnt out. (3) Check the connections of the cable connecting the air switch with the power supply panel. Check the connections of the cable connecting the power supply panel with the MOS plate. 5 The control panel's auxiliary power supply is damaged.
The power indicator light is on. The fan works properly. There is no welding output.	<ol style="list-style-type: none"> 1 Check if all internal cables of the machine are well connected. 2 The output connector is disconnected. 3 The output connector is disconnected or not connected properly. 4 The control circuit s damaged.
The power indicator light is on. The fan works properly. The fault indicator light is on.	<ol style="list-style-type: none"> 1 The overheat protection may be activated. Turn off the power switch and restart the machine, once the fault indication light is off. 2 The overheat protection may be activated. Wait 2-3 minutes. 3 There may be a malfunction in the inverter circuit.

 **WARNING**

The power must be cut off completely before starting any kind of inspection. Otherwise you may suffer serious accidents like electric shock or burns.

