

**SWISHER®**

swisherinc.com

# OWNER'S MANUAL

**MODEL NO.**

**LSED14534**

STARTING SERIAL #:  
L122-265001

**IMPORTANT**  
Read and follow all Safety  
Precautions and Instructions  
before operating this  
equipment.

REV 22-265



# LOG SPLITTER

**Safety**  
**Assembly**  
**Operation**  
**Service and Adjustment**  
**Repair Parts**

SWISHER ACQUISITION INC.  
1602 CORPORATE DRIVE, WARRENSBURG MISSOURI 64093  
PHONE 660-747-8183 TOLL FREE 800-222-8183 FAX 660-747-8650

*Made In The*

**USA**

*of US and Global Parts*

9/22/2022

# LIMITED WARRANTY

The manufacturer's warranty to the original consumer purchaser is: This product is free from defects in materials and workmanship for the period's shown below beginning from the date of purchase by the original consumer purchaser.

As required by CFR § 1060.120, the fuel system related components, which have been certified to this equipment by SAI are to be free of defects in material and workmanship for a period of two (2) years from the date of purchase by the original consumer purchaser.

We will repair or replace, at our discretion, parts found to be defective due to materials or workmanship. This warranty is subject to the following limitations and exclusions:

Engine Warranty	All engines utilized on our products have a separate warranty extended to them by the individual engine manufacturer. Any engine service difficulty is the responsibility of the engine manufacturer and in no way is Swisher, or its agents responsible for the engine warranty. Engine warranty and contact information is as shown in the engine owners manual.
Hydraulic System	1 Year
Materials and Workmanship	3 Years
Limitation	This warranty applies only to products which have been properly assembled, adjusted, and operated in accordance with the instructions contained within this manual. This warranty does not apply to any product of Swisher that has been subject to alteration, misuse, abuse, improper assembly or installation, shipping damage or to normal wear of product.
Exclusions	Excluded from this warranty are normal wear items, normal or routine adjustments, and normal or routine maintenance.

In the event you have a claim under this warranty, you must return the product to an authorized service dealer. All transportation charges, damage, or loss incurred during transportation of parts submitted for replacement or repair under this warranty shall be borne by the purchaser. Should you have any questions concerning this warranty, please contact us toll-free at 1-800-222-8183. The model number, serial number, date of purchase, and the name of the authorized Swisher dealer from whom you purchased the splitter will be needed before any warranty claim can be processed.

**THIS WARRANTY DOES NOT APPLY TO ANY INCIDENTAL OR CONSEQUENTIAL DAMAGES AND ANY IMPLIED WARRANTIES ARE LIMITED TO THE SAME TIME PERIODS STATED HEREIN FOR ALL EXPRESSED WARRANTIES.** Some states do not allow the limitation of consequential damages or limitations on how long an implied warranty may last, so the above limitations or exclusions may not apply to you. This warranty gives you specific legal rights and you may have other rights, which vary from state-to-state. This is a limited warranty as defined by the Magnuson-Moss Act of 1975.

# SAFETY PRECAUTIONS



**This Safety Alert Symbol indicates important messages in this manual. When you see this symbol, carefully read the message that follows and be alert to the possibility of personal injury.**

**Read this manual completely. This machine can amputate hands, feet, and throw objects. Failure to observe the following safety instructions could result in serious injury or death.**

**WARNING:** The engine exhaust from this product contains chemicals known to the state of California to cause cancer, birth defects or other reproductive harm.

**DANGER:** Your log splitter was built to be operated according to the rules for safe operation in this manual. As with any type of power equipment, carelessness or error on the part of the operator can result in serious injury. If you violate any of these rules, you may cause serious injury to yourself or others.

- Read and understand the manual. Learn to operate this equipment in a safe manner. Familiarize yourself with all of the controls in a safe environment before starting to work with this machine.
- DO NOT under any circumstances alter this log splitter. This equipment was designed and engineered in accordance with operating instructions. Altering this equipment, or using this equipment in such a way as to circumvent its design capabilities and capacities, could result in serious injury or fatality and WILL VOID THE WARRANTY.
- Allow ONLY responsible adults who have read this manual to operate this machine. NEVER allow children to operate this machine.
- NEVER operate or allow someone to operate this equipment while under the influence of alcohol, drugs or medication. Being coherent is essential for safety.
- ALWAYS use outdoors with adequate ventilation. DON'T run the engine in an enclosed area. Exhaust gases contain carbon monoxide. This odorless gas can be deadly when inhaled.
- NEVER use splitter for any other purpose than splitting wood. Any other use can result in injury. Your splitter is a precision piece of power equipment, not a toy. Therefore, exercise extreme caution at all times.
- ONLY a single operator is to load and operate the log splitter. KEEP all others, including pets and children, a minimum of 20 feet away from your work area. More accidents occur when more than one person operates the log splitter than any other time.
- ALWAYS wear protective gear such as safety goggles, protective hearing device, steel-toed shoes, and tight-fitting gloves without drawstrings or loose cuffs.
- NEVER wear loose clothing or jewelry that can be caught by moving parts of the splitter and pull you into it. Keep hair away from moving parts.
- NEVER operate your splitter on wet, muddy, or icy surfaces. KEEP work area clean of split wood. Safe footing is essential in preventing accidents.
- ONLY operate splitter on level ground with wheels blocked, not on the side of a hill. It could tip, or rolling logs, poor footing, etc. could cause an accident.

- NEVER operate your splitter near a flame or spark. Hydraulic oil and gasoline are flammable and can explode.
- NEVER fill gas tank while the engine is hot or running. Allow the engine to cool before refueling.
- This unit is equipped with an internal combustion engine and should not be used on or near any unimproved forest-covered, brush-covered or grass-covered land unless the engine's exhaust system is equipped with a spark arrester meeting applicable local or state laws (if any). If a spark arrester is used it should be maintained in effective working order by the operator.

**-NOTE-**

In the state of California, the above is required by law (Section 442 of the California Public Resources Code). Other states may have similar laws. Federal laws apply on federal lands. A spark arrester muffler (optional by manufacturer) is available at your nearest engine dealer. Check legal requirements in your area.

- ONLY use your hands to operate the control lever. NEVER use foot, knee, rope or any extension device.
- Split ONLY one log at a time. NEVER attempt to split two logs on top of each other.
- NEVER place hands or feet between log and splitting wedge or between log and buttplate during forward or reverse stroke. ALWAYS keep fingers clear of splits that open in log during splitting operation.
- DO NOT straddle or reach across the splitting area while operating the splitter.
- DO NOT step over splitter when the engine is running. You may trip or accidentally activate the splitting wedge. Walk around to get to the other side.
- NEVER attempt to load splitter while splitting wedge is in motion. When loading log splitter, place hands on the sides of the log, not the ends.
- NEVER attempt to split woods across the grain. Wood may burst or fly out of your splitter and result in serious injury.
- NEVER leave your splitter unattended with the engine running. Shut off the engine if you are leaving your splitter, even for a short period of time. Someone could accidentally activate the ram and be injured.
- Both ends of the log should be cut as squarely as possible to prevent the log from sliding out of the splitter during operation. Log length should be kept to 24" or less.
- NEVER operate your splitter while it is attached to the tow vehicle.
- BEFORE towing, be certain that the splitter is securely attached to the towing vehicle and that the support leg, beam, 4-way wedge and cylinder are secured in their respective towing positions.
- DO NOT loosen or remove any hydraulic fitting, line or reservoir cap while your splitter or engine is running.
- Fluid escaping from a very small hole can almost be invisible. DO NOT check for leaks with your hand. See maintenance section for instructions. **IF injured by escaping fluid, see a doctor at once. Serious infection or reaction can develop if proper medical treatment is not administered immediately.**
- DO NOT operate your splitter in poor mechanical condition or when it is need of repair.
- ALWAYS disconnect the spark plug wire and place the wire where it cannot contact the spark plug, to prevent accidental starting the engine when setting up, transporting, adjusting or repairing.

# TOWING SAFETY

- Do not allow persons to ride on splitter. Do not carry any cargo or wood on your splitter. It may fall off and endanger vehicles that are following you.
- Be sure support leg is in the travel position and coupling secure. This must also be retracted so as not to interfere while towing. Retract support leg by removing pin, pivoting up, and replacing pin.
- Never exceed 45 MPH while towing your splitter. Be extra cautious when traveling over rough terrain, especially over railroad tracks.
- Always be careful while backing your splitter. You could jackknife your log splitter if not careful.
- Before using splitter, disconnect it from tow vehicle. A log could easily be pushed forward into the vehicle.
- See proper inflation instructions on side of tires.
- Be aware of the extra length of splitter while turning, parking, crossing intersections, and in all driving situations.

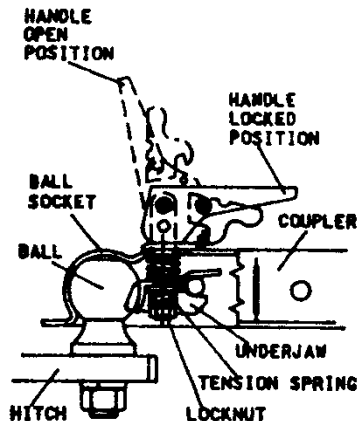

## OPERATION INSTRUCTIONS POSI-LOCK COUPLER

ADJUST COUPLER LOCKING PRESSURE ON BALL BEFORE USE. PLACE HANDLE IN LOCKED POSITION WITH BALL IN COUPLER. TIGHTEN LOCKNUT AGAINST TENSION SPRING SO THAT COUPLER IS NOT LOOSE ON BALL. CORRECT ADJUSTMENT WILL ALLOW HANDLE TO BE RELEASED WITH MODERATE PRESSURE APPLIED TO HANDLE.

TO OPEN, PULL UP ON COUPLER HANDLE AND ROTATE FORWARD. PLACE COUPLER ON BALL WHEN BALL IS COMPLETELY NESTED IN BALL SOCKET, ROTATE COUPLER HANDLE BACKWARD UNTIL HANDLE IS IN LOCKED POSITION.

AFTER TOWING FOR 50 MILES, CHECK COUPLER FOR TIGHTNESS ON BALL. ALWAYS CHECK TIGHTNESS BEFORE TOWING. BE SURE COUPLER HANDLE IS IN LOCKED POSITION.

## WARNING:

NEVER EXCEED WEIGHT CAPACITY AND ALWAYS USE SAFETY CHAINS. ALWAYS USE CORRECT BALL SIZE, MAKING SURE BALL IS COMPLETELY INSERTED INTO COUPLER. LOCK COUPLER HANDLE SECURELY BEFORE TOWING. ALWAYS CHECK FOR DAMAGES AND REPLACE IF DAMAGED. AVOID SHARP TURNS AND STEEP VERTICAL ANGLES WHEN TOWING.

## ASSEMBLY

Refer to the drawings and part lists should it become necessary to disassemble the unit for repair or replacement of parts.

Inspect all components for damage. If you believe you have a damaged part please contact customer service immediately at 1-800-222-8183.

**WARNING:** Exercise extreme caution, as parts are very heavy. Sufficient persons or mechanical handling equipment should be used.

Refer to uncrating and assembly instructions for assembly procedures.

## OPERATION

**INTENDED USE:** This log splitter is intended and designed to only split wood. NEVER use for any other purposes. Doing so can cause injury or VOID THE WARRANTY.

**IMPORTANT:** This unit is shipped with oil but without gasoline in the engine. After assembly, see separate Engine Manual for proper fuel and oil recommendations.

**WARNING:** *DO NOT START OR RUN THE LOG SPLITTER WITHOUT OIL IN THE ENGINE AND HYDRAULIC RESERVOIR.*

### FILLING THE HYDRAULIC RESERVOIR

Fill the hydraulic reservoir to the top mark on the dipstick or, depending on your Log Splitter model, to the lower fill line of the reservoir with Dexron® III / Mercon® automatic transmission fluid, 10W AW hydraulic fluid or Pro-Mix™ AW-32 Hydraulic oil. After the hydraulic reservoir and the engine crankcase are filled correctly with their respective oils, set the throttle and turn on the fuel shut-off valve. The engine is now ready to start by following the starting instructions listed below. With the engine running, move the hydraulic valve lever toward the wedge. This will cause the cylinder to extend and expel air. When the cylinder is fully extended, retract it. Repeat this procedure several times. (An erratic movement of the cylinder and wedge indicates that there is air in the system). Once the cylinder has a smooth and constant speed indicating that all air has been expelled, shut the system off and refill the reservoir until the fluid is in the safe operating range as specified by the marks on the dipstick.

### START UP

**WARNING:** *DO NOT START OR RUN THE LOG SPLITTER WITHOUT OIL IN THE ENGINE AND HYDRAULIC RESERVOIR.*

See separate Engine Manual for fuel and oil recommendations. Your log splitter has come equipped with a fuel shut-off valve for storage and towing purposes. The engine will only start when the throttle lever and fuel shut-off valve are turned to their ON positions.

### \*STARTING INSTRUCTIONS

*\*See the engine manufacturers operating manual for starting and maintenance instructions.*

NOTE: For cold engine starting “choke” may be required. The choke position of the throttle lever is the extreme up position, full throttle is the detent position just slightly lower than the choke position.

1. Put the key into the ignition switch.
2. Turn the key to the START position on the ignition switch. Usually engine will start within 3 seconds
3. When engine starts, position the throttle control at “FAST.” The throttle must be set in the fast position for maximum performance.
4. To stop engine, move throttle lever to “SLOW” for a few seconds then turn the ignition key to the “OFF” position.

**IMPORTANT:** This engine is not equipped with a spark arrester muffler. It is a violation of California Public Resource Code Section 4442 to use or operate the engine on any forest-covered, brush-covered, or grass-covered land. Other states or federal areas may have similar laws.

**4-WAY WEDGE OPERATION:** See 18851 Owners Manual in parts bag.

## SPLITTER OPERATION

1. Set up the log splitter in a clear, level area and block the wheels. The suction port on the tank should always be on the lower side of the log splitter.
2. Place a log on the beam, against the foot plate. Make sure the log is securely on the foot plate and up against the beam.
3. Depress the valve lever so that the cylinder will drive the wedge into the log. Extend the cylinder until the log splits or to the end of its stroke. If the log has not completely split after the cylinder has reached the end of its extension, retract the cylinder, reposition log and repeat process. **NOTE:** Leaving the valve in the “actuate” position at the end of the stroke may damage the pump. Always use extra care when splitting logs with ends that are not square.

**NOTE:** To extend the life of the hydraulic cylinder, avoid “BOTTOMING OUT” the cylinder.

4. When using the Log Splitter in the vertical position, make sure the beam latch is engaged as shown below. Pull the bent pin outward then twist and release it to hold the I-beam in place.

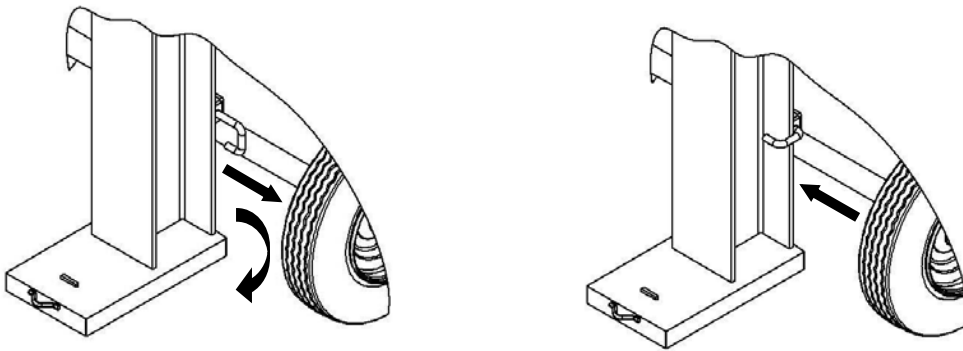

## TOWING SAFETY

This unit should not be towed on any street, highway, or public road without checking the existing federal, local, and state laws. Any licensing or modifications such as taillights, etc., need to comply with existing federal, local, or state vehicle requirements is the sole responsibility of the purchaser. Obey all regulations when towing on public roads and highways. See also **SAFETY PRECAUTIONS**.

**\*Turn the fuel shut-off valve OFF to prevent flooding of the engine while traveling.**

**\*Ensure that 4-way wedge is placed securely in the towing position, fastened to the motorbase or in the towing vehicle.**

**\*Be careful when backing up. You can easily jack-knife your splitter.**

## TOWING AT NIGHT

The requirements for taillights are based on States regulations. Some states allow towing at night as long as the towed equipment does not visibly impair the tow vehicle taillights. This is based on a state, to state requirements. The customer is responsible for meeting the states requirements.

**If a “Statement of Origin” is required in your state, see your local dealer to receive one.**

## HYDRAULIC SAFETY

The hydraulic system on your splitter requires careful inspection along with the mechanical parts. Be sure to replace any frayed, kinked, cracked or otherwise damaged hydraulic components. Just because it isn't leaking today doesn't mean that it will not fail tomorrow.

\*Fluid escaping from a very small hole can almost be invisible. Do not check for leaks with your hand. Escaping fluid under pressure can have sufficient force to penetrate skin causing serious personal injury or even death. Leaks can be detected by passing a piece of cardboard or wood over the suspected leak and looking for discoloration. **IF injured by escaping fluid, see a doctor at once. Serious infection or reaction can develop if proper medical treatment is not administered immediately.**

\*Should it become necessary to loosen or remove any hydraulic fittings, lines or reservoir cap, be sure to relieve all pressure by shutting off the engine and moving the control handle back and forth several times.

\*NEVER remove the cap from the hydraulic tank or reservoir while the unit is running. Hot oil under pressure could result in serious injury. See also **SAFETY PRECAUTIONS.**

**The pressure relief valve on your splitter is preset at the factory. DO NOT adjust the valve. Only a qualified technician should perform this adjustment.**

\*NEVER run the log splitter for extended periods of time without cycling the cylinder. Running the unit without cycling hydraulic fluid throughout the entire system will cause excessive heat build up in all components.

## **MAINTENANCE AND STORAGE**

**WARNING: DISCONNECT THE SPARK PLUG BEFORE PERFORMING ANY MAINTENANCE.**

Consult the operating and maintenance instructions of the engine manufacturer for engine care.

**Always check the oil level of the hydraulic reservoir before operation. Operating without an adequate oil supply will cause severe damage to the pump.** Change the hydraulic fluid in the reservoir after every 100 hours of operation. Change the hydraulic filter after every 50 hours of operation (use only a 10 micron hydraulic filter).

Periodically check that all nuts, bolts, screws, clamps and fittings are tight and secure.

To keep your splitter in top working condition perform all recommended maintenance procedures before you use your splitter.

If the wedge becomes dull or nicked a grinder or sharpening tool can be used to sharpen it.

Completely drain the fuel tank prior to storage. Always store gasoline in an approved, tightly sealed container. Store container in a dry, cool place with adequate ventilation. Keep fuel away from areas where fumes could contact open flame, pilot light or sparks.

**Be aware of the environment when disposing of used petroleum products. Please dispose of used hydraulic fluid, engine oil and any by products from the maintenance of your splitter at approved recycling centers.**

Should it become necessary to disassemble the unit for repair or replacement of parts, refer to the drawings and parts list on the following pages. Exercise extreme caution, as some parts are very heavy and will require sufficient persons or mechanical handling equipment.

Your Swisher Log Splitter has been produced with components designed specifically to this machine. Although standard springs, hardware and ect may look similar to parts used on other machinery, they may in some cases be made of a different construction and/or materials. All replacement parts must meet manufacturer's specifications.



The operation of any splitter can produce foreign objects which can be thrown into the eyes, resulting in severe eye damage. Always wear certified safety glasses or wide-vision safety goggles over spectacles before staring any splitting machine and while operating such a machine.



The operation of any splitter produces sound waves that are damaging to the human ear. Ear protection is recommended.



# SAFETY DECALS

Replace decals immediately if damaged.



OD16 – FUEL SHUT OFF DECAL



12494 – HYDRAULIC FILL PLUG DECAL



12549 – DO NOT EXCEED 45 MPH DECAL



12532 – HYDRAULIC OIL DECAL

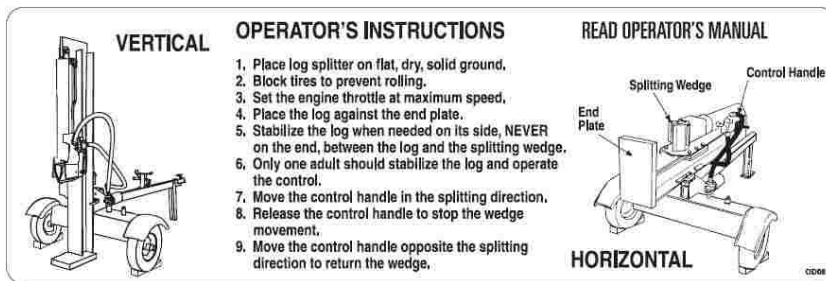

12492 – OPERATOR INSTRUCTION DECAL



11427 – DANGER DECAL

# ASSEMBLY DETAIL

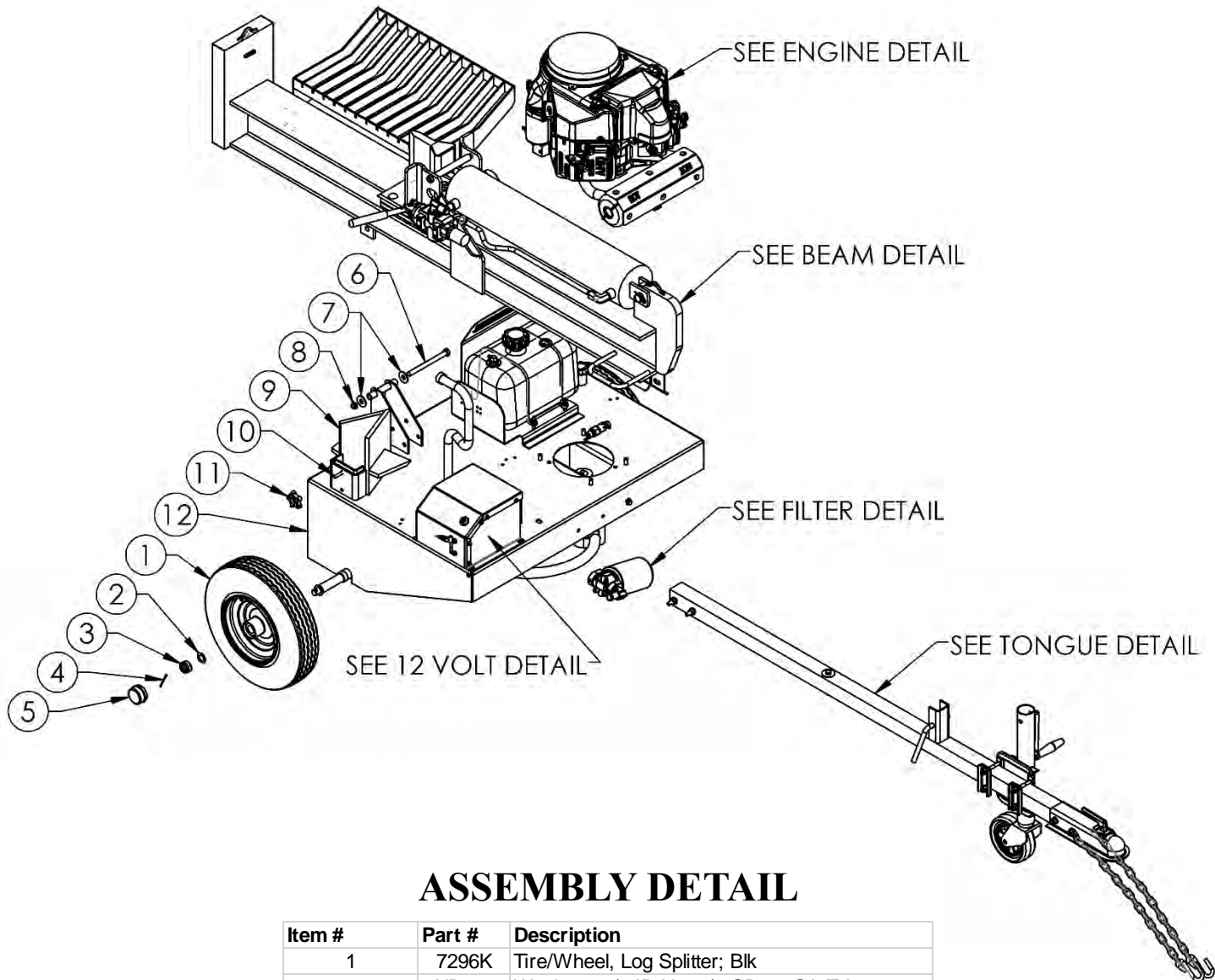

# ASSEMBLY DETAIL

Item #	Part #	Description
1	7296K	Tire/Wheel, Log Splitter; Blk
2	NB179	Washer - 3/4 ID X 1 1/4 OD 18 GA ZY
3	2203CN	Nut - Castle 3/4-16, .625 Tall, Grade 2
4	NB633	Pin - Cotter, 1/8 X 2(Ext Prng Crbn Stl)
5	2203DC	Cover - Dust, Wheel Hub
6	NB151	Bolt - 1/2-13 X 6 HCC GR5 ZP
7	NB555	Washer - USS Flat, 1/2 ZY
8	NB688	Nut - Nyloc Jam, 1/2-13 ZY
9	18839TK	Weldment - Wedge, 4-Way; Txt Blk
10	NB587	Bolt - Carriage, 5/16-18 X 1 3/4 ZY Gr 2
11	2030	Knob - Black Plastic
12	20077TK	Weldment - Motorbase, LS; Txt Blk
NOT SHOWN	20081	Hose - Hydraulic Return, 3/4"ID X 61"
NOT SHOWN	22419	Coil Cover - Return Hose, 5'
NOT SHOWN	19165	Hose - Hydraulic Pressure, 60"
NOT SHOWN	19811	Coil Cover - Pressure Hose, 5'
NOT SHOWN	20080	Hose - Suction

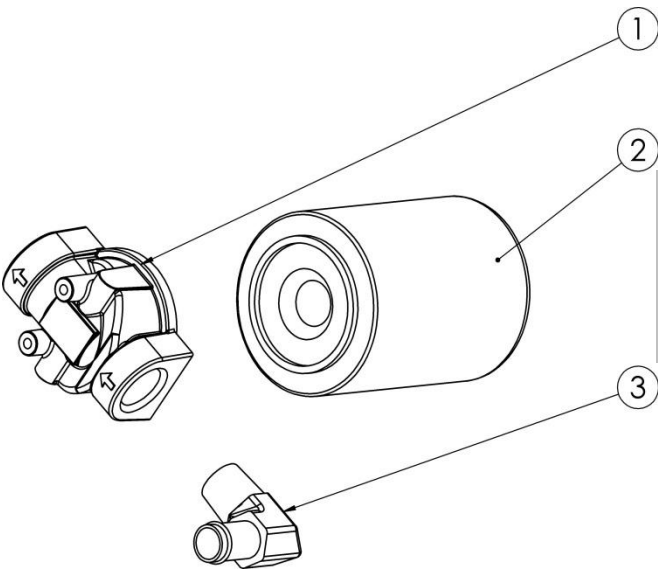

## FILTER DETAIL

Item #	Part #	Description
1	LS1112	Head - Filter (FPC3012NXXR4X)
2	LS1113	Filter - Element
3	7329	Fitting - Line Return (4501-12-12) YZ

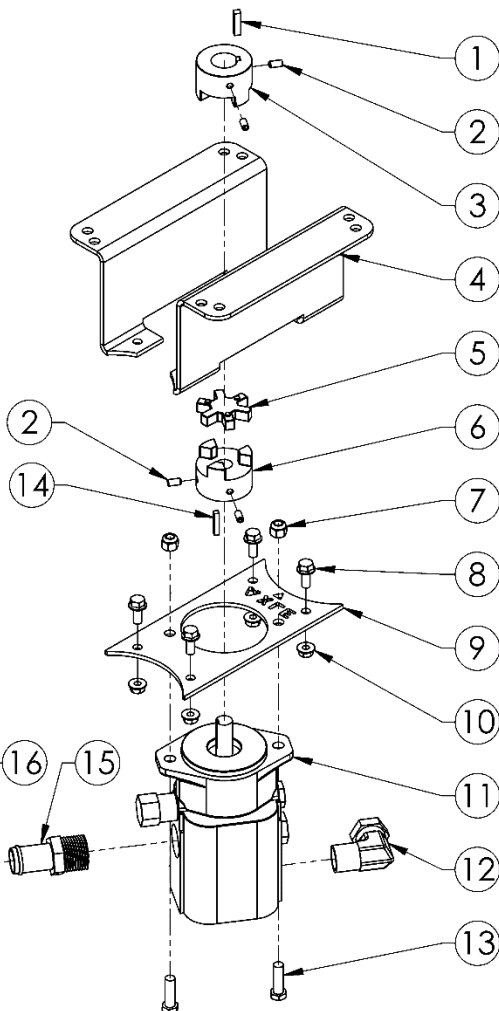

## PUMP DETAIL

Item #	Part #	Description
1	9031	Key Stock - 1/4 X 1
2	712127	Screw - Set 1/4-20 X 1/2
3	14903	Coupler - 1" Shaft
4	20070*	Bracket - Pump Mount
5	14904	Jaw Coupling Insert
6	20015	Coupler - .625" ID
7	NB182	Nut - Nyloc 3/8-16 ZY
8	NB596	Bolt - Serr Flange, 5/16-18 X 3/4 Gr 5
9	20069*	Bracket - Pump Mount, 22 GPM
10	NB170	Nut - Serr Flange 5/16-18 ZY Case Hrd
11	19166	Pump - Hydraulic, 22 GPM
12	20083	Fitting - Male Pipe Elbow Swivel 3/4"
13	NB618	Bolt - 3/8-16 X 1 1/4 GR5 ZY
14	9030	Key Stock - 3/16 X 1
15	19175	Fitting - Hydraulic Input 1" BARB 1" NPT
16	LS4999	Clamp - Hose No. 16 (1 1/16" X 2")

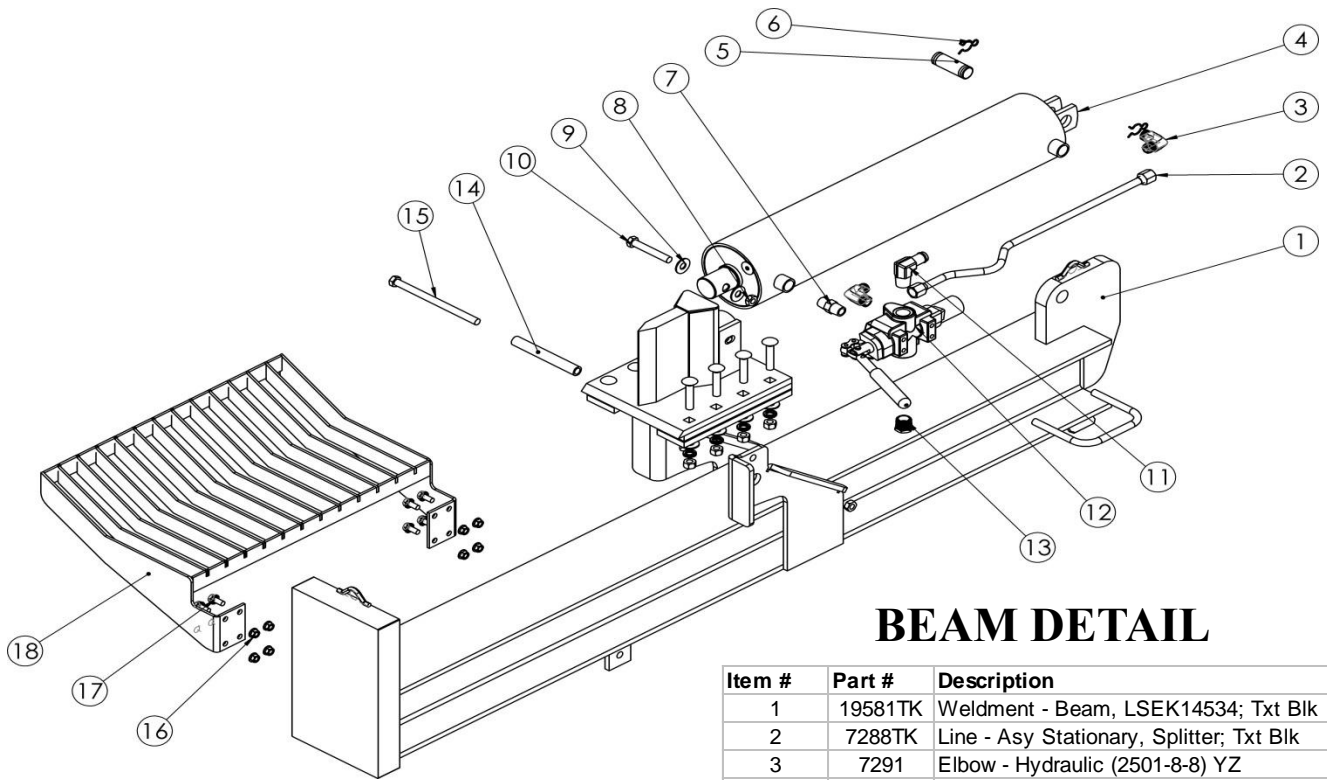

## BEAM DETAIL

Item #	Part #	Description
1	19581TK	Weldment - Beam, LSEK14534; Txt Blk
2	7288TK	Line - Asy Stationary, Splitter; Txt Blk
3	7291	Elbow - Hydraulic (2501-8-8) YZ
4	7355TK	Cylinder - 5 X 24 X 2 Painted
5	7293	Pin - Cylinder to Beam Zp
6	NB642	Cotter - Hairpin #23-09 .093 X 1-13/16
7	7292	Pipe - Nipple (5404-8-8) ZY
8	NB121	Nut - Jam Lock, 1/2-13 2-Way Gr A
9	NB555	Washer - USS Flat, 1/2 ZY
10	12669	Bolt - 1/2-13 X 3 1/4 GR8 Alloy ZY
11	7329	Fitting - Line Return (4501-12-12) YZ
12	7287TK	Valve - Control; Splitter, Painted
13	19699	Fitting - Hydraulic 3/4" ML 1/2" FML NPT
14	19578TK	Spacer - Log Stripper; Txt Blk
15	NB108	Bolt - 1/2-13 X 7 HCC GR5 ZP
16	NB779	Nut - Serr Flange, Hex ZY 3/8-16
17	NB780	Bolt - Serr Flange, ZY 3/8-16X3/4 Gr5
18	19579TK	Weldment - Log Table; Txt Blk

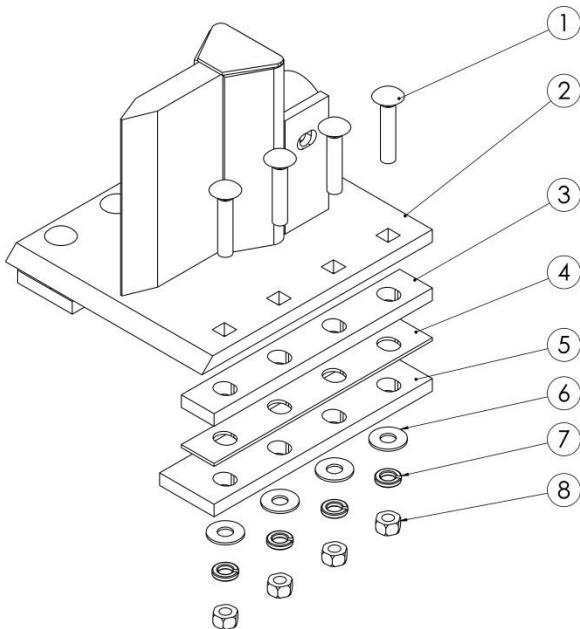

## WEDGE DETAIL

Item #	Part #	Description
1	NB643	Bolt - Carriage 1/2-13 X 2 1/2 GR5 ST ZY
2	7233TK	Wedge - Painted
3	7237TK	Spacer - 4 Slot .500 Thick -Txt Blk
4	7388TK	Spacer - 4 Slot, Textured Black 11GA
5	7333TK	Plate - Bottom Head Slide, Painted
6	NB555	Washer - USS Flat, 1/2 ZY
7	NB508	Washer - Lock, 1/2 ZY Medium Duty
8	NB213Z	Nut - 1/2-13 GR2 ZY

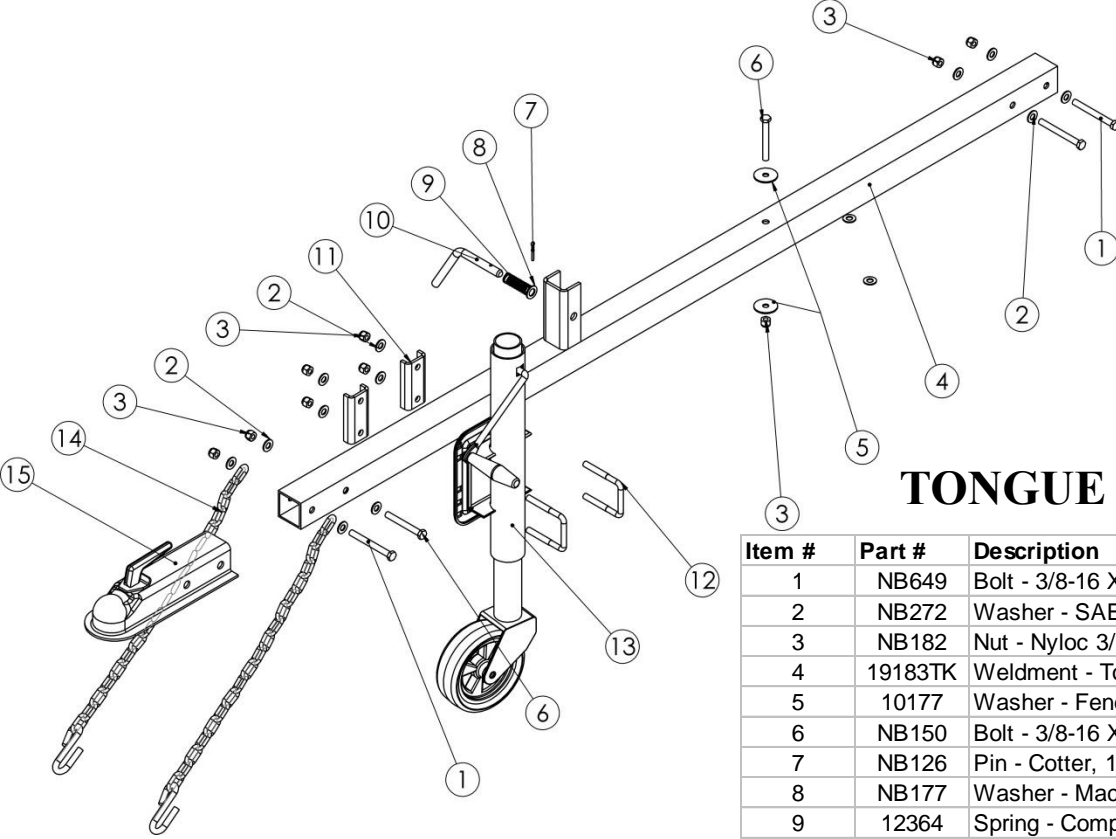

## TONGUE DETAIL

Item #	Part #	Description
1	NB649	Bolt - 3/8-16 X 3 1/2 GR5 ZY
2	NB272	Washer - SAE Flat 3/8 ZY Carbon Steel
3	NB182	Nut - Nyloc 3/8-16 ZY
4	19183TK	Weldment - Tongue, LS; Txt Blk
5	10177	Washer - Fender 3/8 X 1.5, Crbn Stl GR 2
6	NB150	Bolt - 3/8-16 X 3 HCC GR5 ZY
7	NB126	Pin - Cotter, 1/8 X 1, Crbn Stl Ext Prng
8	NB177	Washer - Mach 1/2 NR 14 GA
9	12364	Spring - Compression .620ID X 2" ZP
10	12345	Pin - Beam Lock 1/2 X 3
11	19477TK	Plate - Support, Kickstand Txt Blk
12	12447	Ubolt - SQ , 3/8-16X2.437 X 3 Lg GR 5 ZY
13	19179	Jackstand
14	7366	Chain - Safety, W/S Hook Zp
15	7365	Coupler - 2" Ball

## FUEL DETAIL

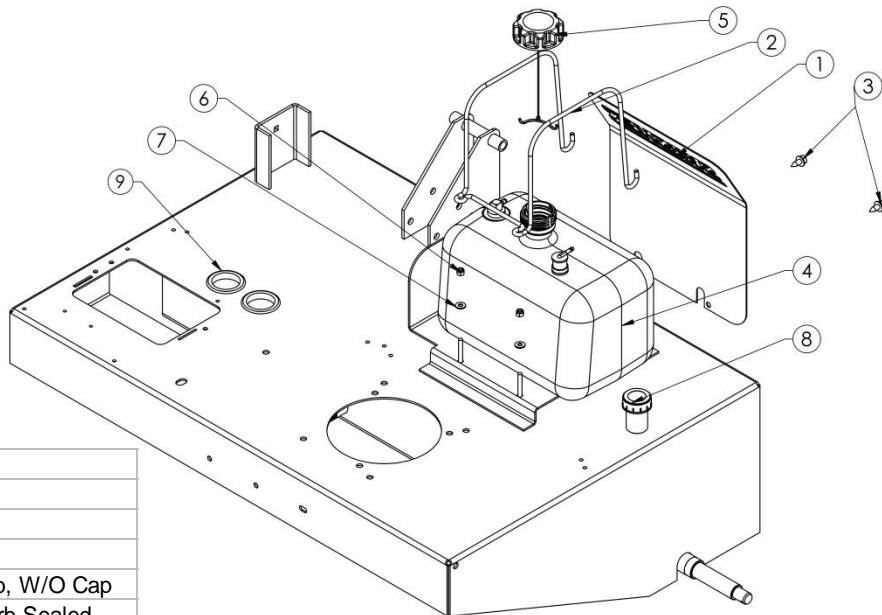

Item #	Part #	Description
1	19565TK	Cover - Fuel tank, Txt Blk
2	18225	Bracket - Fuel Tank
3	26X249	Screw - .312-18 X .75
4	18214	Fuel Tank - 2.5 Gallon, Carb, W/O Cap
5	18221	Cap, Fuel - 2.50 Gallon, Carb Sealed
6	NB180	Nut - Nyloc 1/4-20
7	NB274	Washer - SAE Flat 1/4 ZY
8	12379	Breather Cap W/Dipstick
9	12441	Grommet - PVC 1.75ID X 2.375OD, 2GD
NOT SHOWN	18223	Clamp - Fuel Line
NOT SHOWN	6FLC	Clamp - Fuel Line Hose; 1/2"OD .092 Diam
NOT SHOWN	11782	Line - Fuel, Bulk; 1/4" Low Perm
NOT SHOWN	18232	Line - Fuel, Bulk; 3/16" Low Perm

# ENGINE DETAIL (Kawasaki)

Item #	Part #	Description
1	N/A	Engine - KAW 14.5HP, LS
2	16000	Valve - Oil Drain
3	18810	Adapter - Oil Drain, Kawasaki
4	NB711	Washer - Split Lock, 3/8 ZY, Medium
5	NB618	Bolt - 3/8-16 X 1 1/4 GR5 ZY
6	NB170	Nut - Serr Flange 5/16-18 ZY Case Hrd
7	NB596	Bolt - Serr Flange, 5/16-18 X 3/4 Gr 5
8	19181	Muffler - KAW 14.5HP, LS
NOT SHOWN	7414	Valve - Fuel Shut Off (Inline)
NOT SHOWN	N/A	Muffler Mounting Bolt(Comes with Engine)
NOT SHOWN	N/A	Muffler Mounting Washer(Comes with Engine)
NOT SHOWN	N/A	Exhaust Gasket(Comes with Engine)

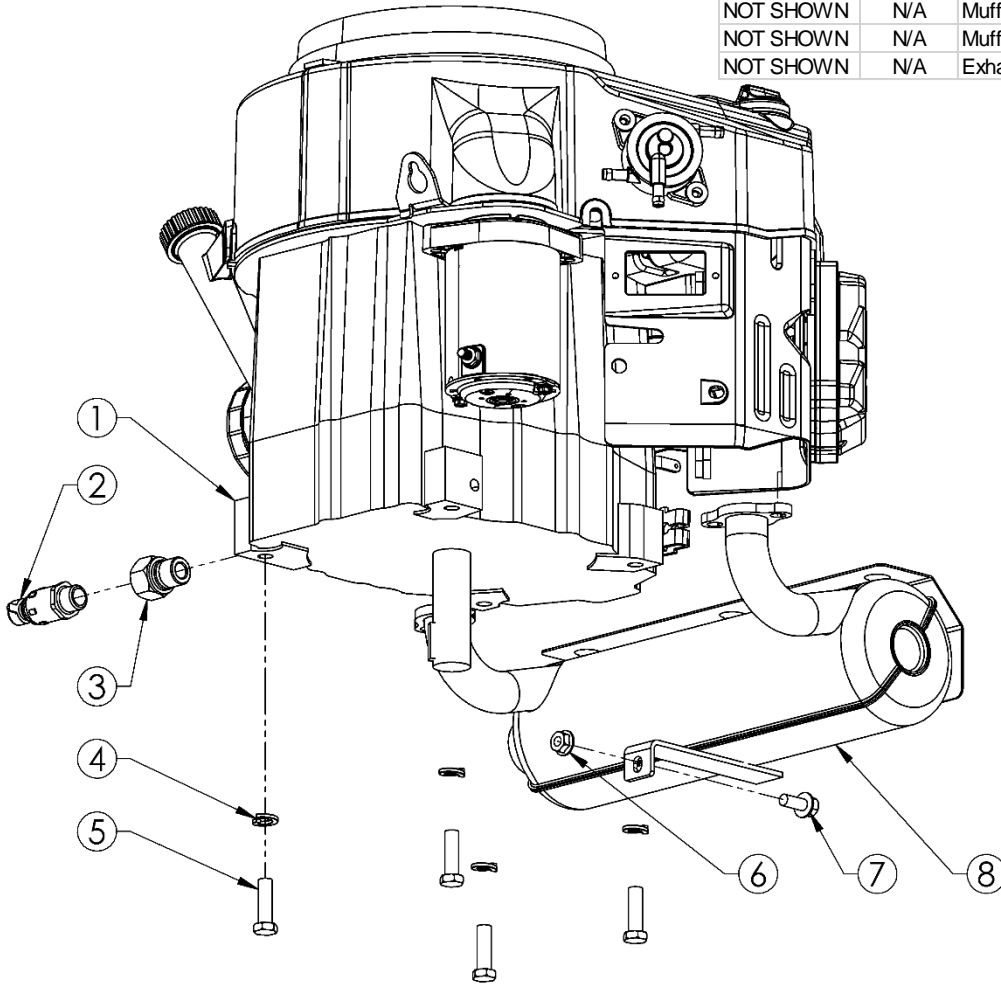

## CARBON CANISTER DETAIL (CA MODELS ONLY)

ITEM #	PART #	DESCRIPTION
1	024900	Nut - 10-24 Nylon Lock
2	17127	Bracket - Carbon Canister
3	024203	Bolt - 10-24 X 3/4 Phil Truss Head
4	18224	Carbon Canister
5	18219	Cable Tie
NOT SHOWN	18232	Line - Fuel, Bulk; 3/16" Low Perm

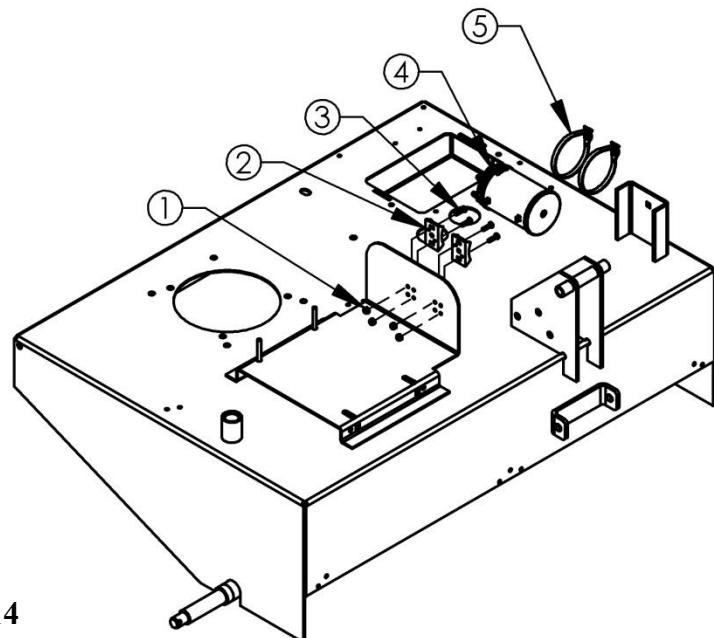

# 12 VOLT ACCESORIES

ITEM NO.	PART #	DESCRIPTION
1	23318TK	Plate- Front, Console
2	9088	WASHER - LOCK KEY SWITCH
3	9087	NUT - KEY SWITCH
4	20148TK	Weldment- Battery Hold Down
5	NB180	1/4-20 Nylok Nut
6	26X249	SCREW - .312-18 x .75 BLACK ZINC
7	NB274	1/4 SAE WASHER
8	20143TK	Plate-Left side, Console
9	20145TK	Plate-Rear, Console
10	NB524	1/4-20 Flange Nut
11	NB551	BOLT, 1/4-20 X 4.00 LONG
12	NB690	1/4-20 X 3/4 Serrated Flange
13	NB161	#14 X 3/4 HX TEK SCREW ZP

ITEM NO.	PART #	DESCRIPTION
14	20142TK	Plate- Right side, Console
15	24206	BOLT - 12 x 1/2 Hex Self Tap
16	1002004	SOLENOID - 3 POLE
17	BATPAD	BATTERY PAD
18	3623	KEY SWITCH
19	20917	Cable - Throttle/Choke, 54"
20	AS013	STRAP
NOT SHOWN	AS084	Electrical - 5 Amp Fuse
NOT SHOWN	19187	Wire Harness - Kawasaki
NOT SHOWN	BC24	Cable - Battery, 24" Red
NOT SHOWN	BCBT	Boot - Rubber, Small, Battery Cable
NOT SHOWN	BCS	Cable - Battery, 10" Black
NOT SHOWN	BCSR	Cable - Battery, 10" Red

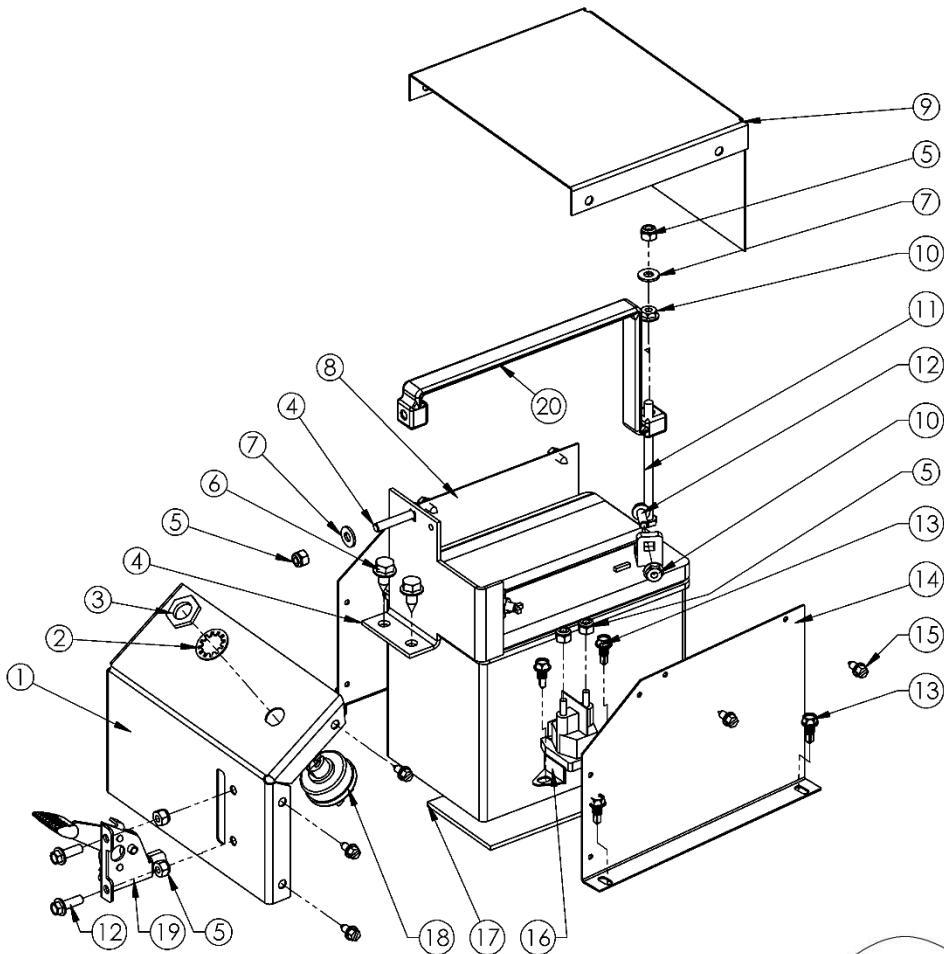

## BEAM LATCH DETAIL

ITEM #	PART #	DESCRIPTION
1	18821	Pin - Beam Latch
2	18822	Spring - Compression
3	18823	Washer - Flat, 1/2"
4	NB126	Pin - Cotter

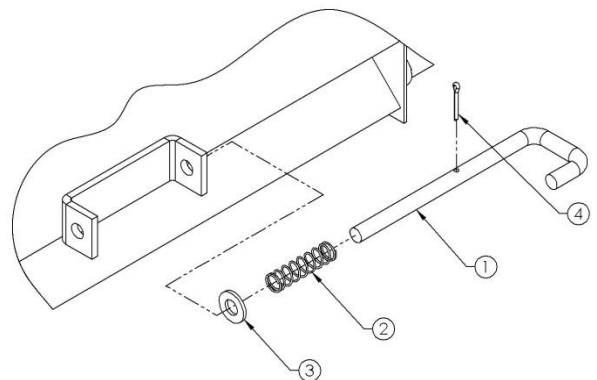

# WIRING SCHEMATIC

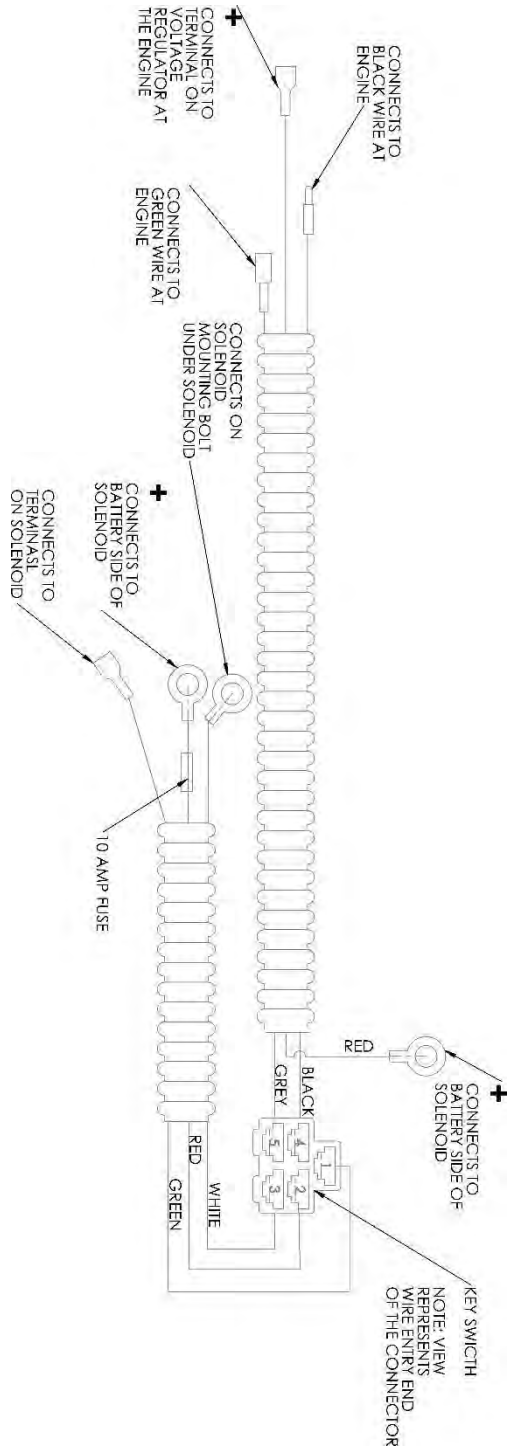



# TROUBLESHOOTING

Engine is hard to start or runs erratically.	<ol style="list-style-type: none"> <li>1. Spark plug wire loose.</li> <li>2. Blocked fuel line or stale fuel.</li> <li>3. Water or dirt in fuel system.</li> <li>4. Dirty air cleaner.</li> <li>5. Carburetor out of adjustment.</li> </ol>	<ol style="list-style-type: none"> <li>1. Connect and tighten spark plug wire.</li> <li>2. Clean fuel line; fill tank with clean, fresh gasoline</li> <li>3. Drain fuel tank. Refill with fresh gasoline.</li> <li>4. Clean or replace air cleaner.</li> <li>5. See authorized service center.</li> </ol>
Cylinder rod will not extend or contract.	<ol style="list-style-type: none"> <li>1. Pump coupling system damaged.</li> <li>3. Low hydraulic fluid.</li> <li>4. Hydraulic lines blocked.</li> <li>5. Damaged or broken pump.</li> <li>6. Damaged control valve.</li> </ol>	<ol style="list-style-type: none"> <li>1. Replace faulty coupler components.</li> <li>3. Fill hydraulic tank to correct fluid level.</li> <li>4. Flush and clean hydraulic system.*</li> <li>5. See authorized service center.</li> <li>6. See authorized service center.</li> </ol>
Cylinder rod is slow or erratic while extending and contracting.	<ol style="list-style-type: none"> <li>1. Low hydraulic fluid.</li> <li>2. Contaminated hydraulic fluid.</li> <li>3. Excessive pump inlet vacuum.</li> <li>4. Damaged pump.</li> <li>5. Damaged control valve.</li> <li>6. Internal cylinder damage.</li> </ol>	<ol style="list-style-type: none"> <li>1. Fill hydraulic tank to correct fluid level.</li> <li>2. Drain fluid, flush system, and refill.</li> <li>3. Make certain pump hoses are clear and unblocked. Make certain hose is not collapsing under suction.</li> <li>4. See authorized service center.</li> <li>5. See authorized service center.</li> <li>6. See authorized service center.</li> </ol>
Cylinder is leaking.	<ol style="list-style-type: none"> <li>1. Broken seals.</li> <li>2. Scored cylinder.</li> </ol>	<ol style="list-style-type: none"> <li>1. See authorized service center.</li> <li>2. See authorized service center.</li> </ol>
Engine will not turn over.	<ol style="list-style-type: none"> <li>1. Weak or dead battery.</li> <li>2. Blown fuse.</li> <li>3. Corroded battery terminals.</li> <li>4. Loose or damaged wiring.</li> <li>5. Faulty ignition switch.</li> <li>6. Faulty solenoid.</li> </ol>	<ol style="list-style-type: none"> <li>1. Recharge or replace battery.</li> <li>2. Replace fuse.</li> <li>3. Clean battery terminals.</li> <li>4. Check all wiring.</li> <li>5. Check/replace ignition switch.</li> <li>6. Check/replace solenoid.</li> </ol>
Engine clicks but will not start.	<ol style="list-style-type: none"> <li>1. Weak or dead battery.</li> <li>2. Corroded battery terminals.</li> <li>3. Loose or damaged wiring.</li> <li>4. Faulty solenoid.</li> </ol>	<ol style="list-style-type: none"> <li>1. Recharge or replace battery.</li> <li>2. Clean battery terminals.</li> <li>3. Check all wiring.</li> <li>4. Check/replace solenoid.</li> </ol>
Battery will not charge.	<ol style="list-style-type: none"> <li>1. Bad battery.</li> <li>2. Corroded battery terminals.</li> <li>3. Faulty solenoid.</li> <li>4. Bad alternator.</li> </ol>	<ol style="list-style-type: none"> <li>1. Replace battery.</li> <li>2. Clean battery terminals.</li> <li>3. Check/replace solenoid.</li> <li>4. See authorized service center.</li> </ol>

**NOTE:** For repairs beyond those listed here, contact your nearest authorized service center.

\* Flushing the reservoir tank and hoses with kerosene whenever service is performed on the tank, hydraulic pump or valve is recommended. Contact an authorized service center.

# MAINTENANCE LOG

Date of Service	Service Performed		Notes

# SPECIFICATIONS

<b>Splitting Force</b>	34 Tons*
<b>Engine</b>	14.5 HP Kawasaki, 603CC
<b>Battery</b>	12V Type U1L (not included)
<b>Splitting Positions</b>	Horizontal and Vertical
<b>Cylinder Size</b>	5" X 24"
<b>Pump</b>	2 Stage with Heavy Duty Bearings
<b>Pump Specs</b>	22 Gallons Per Minute
<b>Valve</b>	Auto Return
<b>Drive System</b>	Heavy Duty Direct Drive Coupling
<b>Hydraulic System Fluid Capacity</b>	15 Gallons (13.5-14 Gallons required for normal operation)
<b>Maximum Log Length</b>	25 1/2"
<b>Tire Specs</b>	4.00 X 4.80 X 8 with High Speed Bearings
<b>Ball Hitch</b>	2" Ball
<b>Unit Weight</b>	751 Lbs

\*Splitting force rating is consistent with the current industry standard for calculation.

## NOTES:

---

---

---

---

---

---

---

---

---

---

---



swisherinc.com

## OWNER'S MANUAL

**MODEL NO.  
LSED14534**

# LOG SPLITTER

## HOW TO ORDER REPAIR PARTS:

Each Log Splitter has its own serial number. Each engine has its own serial number. The serial number for the Log Splitter will be found on the right hand side of the hydraulic oil reservoir. The serial number for the engine will be found on the top of the blower fan housing.

All Log Splitter parts listed herein may be ordered directly from Swisher, your nearest Swisher dealer, or from our website.

All engine parts may be ordered from the nearest dealer of the engine supplied with your log splitter. Parts subject to change without notice.

WHEN ORDERING PARTS, PLEASE HAVE THE FOLLOWING INFORMATION AVAILABLE:

- \* PRODUCT – SWISHER LOG SPLITTER
- \* SERIAL NUMBER - \_\_\_\_\_
- \* MODEL NUMBER - \_\_\_\_\_
- \* ENGINE MODEL NUMBER - \_\_\_\_\_
- TYPE - \_\_\_\_\_
- \* PART NUMBER
- \* PART DESCRIPTION

www.swisherinc.com  
TELEPHONE - 1-800-222-8183  
FAX - 1-660-747-8650

**SWISHER**  
1602 CORPORATE DRIVE  
WARRENSBURG MO 64093



CHANGING YOUR LANDSCAPE SINCE 1945